



MOTOROLA

Service Manual
Wartungsanleitung
Manuel de Réparation

HT800

146-162 MHz
157-174 MHz

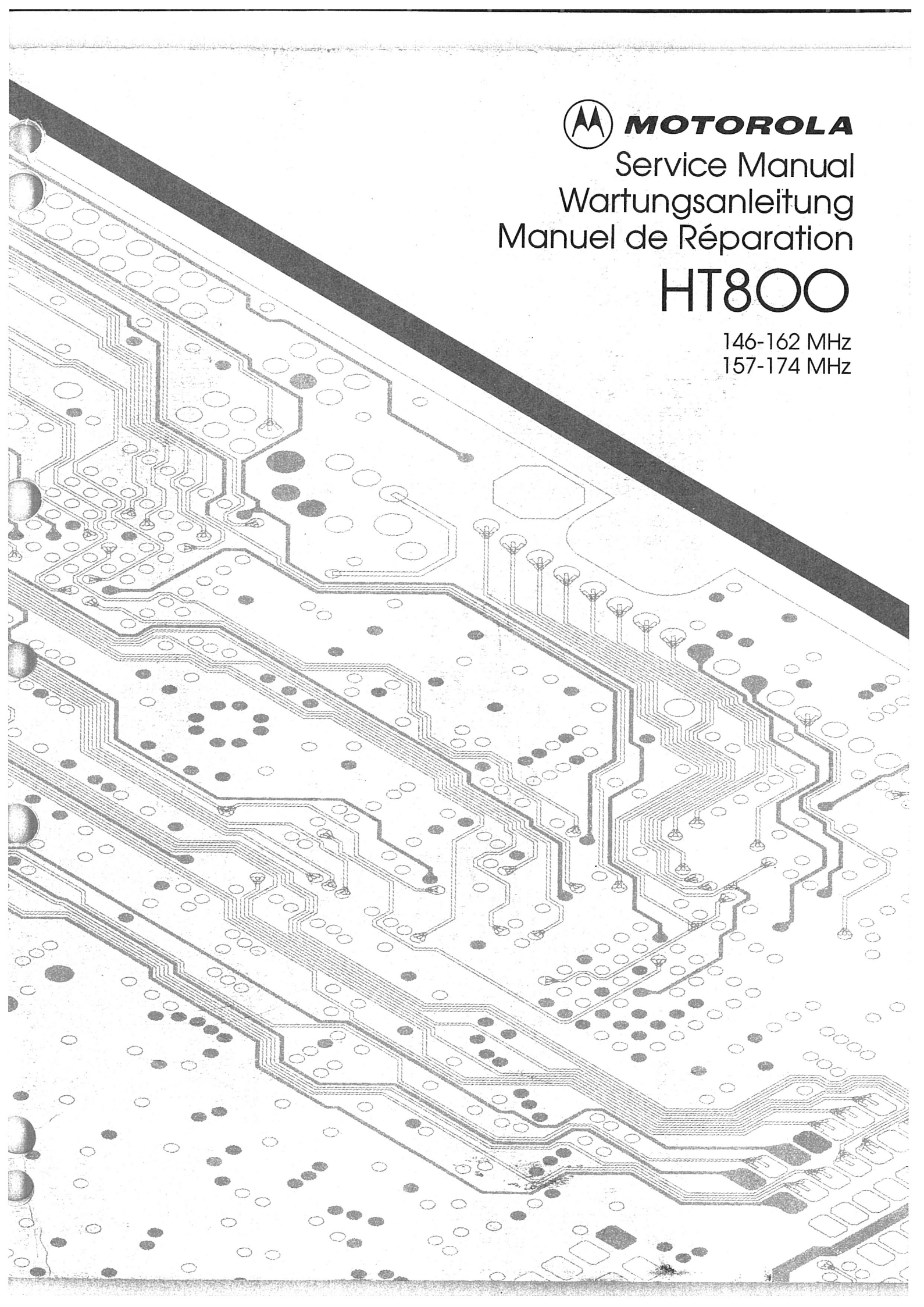

SPECIFICATIONS

GENERAL	TRANSMITTER	RECEIVER																																								
<p>FREQUENCY RANGE: 146-174MHz</p> <p>POWER SUPPLY: Nickel-Cadmium Battery</p> <p>BATTERY DRAIN- at 10VDC</p> <table style="width: 100%; border-collapse: collapse;"> <tr> <td></td> <td style="text-align: center;">(MD)H23</td> <td style="text-align: center;">(MD)H33</td> <td style="text-align: center;">(MD)H43</td> </tr> <tr> <td>Standby:</td> <td style="text-align: center;">*43mA</td> <td style="text-align: center;">*43mA</td> <td style="text-align: center;">*43mA</td> </tr> <tr> <td>Receive:</td> <td style="text-align: center;">*150mA</td> <td style="text-align: center;">*150mA</td> <td style="text-align: center;">*150mA</td> </tr> <tr> <td>Transmit:</td> <td style="text-align: center;">**555mA</td> <td style="text-align: center;">**775mA</td> <td style="text-align: center;">**1600mA</td> </tr> </table> <p>*Add 8mA with Remote Antenna **Add 25mA with Remote Antenna</p> <p>DIMENSIONS:</p> <p>WIDTH: 66.8mm (2.63")</p> <p>DEPTH: 35.3mm (1.39")</p> <p>HEIGHT:</p> <table style="width: 100%; border-collapse: collapse;"> <tr> <td>Radio Only</td> <td style="text-align: center;">99.0mm</td> <td style="text-align: center;">(3.90")</td> </tr> <tr> <td>Radio with Battery</td> <td></td> <td></td> </tr> <tr> <td>Medium Capacity</td> <td style="text-align: center;">161.3mm</td> <td style="text-align: center;">(6.35")</td> </tr> <tr> <td>High Capacity</td> <td style="text-align: center;">177.3mm</td> <td style="text-align: center;">(6.98")</td> </tr> </table> <p>WEIGHT:</p> <table style="width: 100%; border-collapse: collapse;"> <tr> <td>Radio Only</td> <td style="text-align: center;">383 g</td> <td style="text-align: center;">(13.5 oz)</td> </tr> <tr> <td>Radio with Battery (Nickel-Cadmium)</td> <td></td> <td></td> </tr> <tr> <td>Medium Capacity</td> <td style="text-align: center;">612 g</td> <td style="text-align: center;">(21.6 oz)</td> </tr> <tr> <td>High Capacity</td> <td style="text-align: center;">684 g</td> <td style="text-align: center;">(24.1 oz)</td> </tr> </table>		(MD)H23	(MD)H33	(MD)H43	Standby:	*43mA	*43mA	*43mA	Receive:	*150mA	*150mA	*150mA	Transmit:	**555mA	**775mA	**1600mA	Radio Only	99.0mm	(3.90")	Radio with Battery			Medium Capacity	161.3mm	(6.35")	High Capacity	177.3mm	(6.98")	Radio Only	383 g	(13.5 oz)	Radio with Battery (Nickel-Cadmium)			Medium Capacity	612 g	(21.6 oz)	High Capacity	684 g	(24.1 oz)	<p>RF OUTPUT- (MD)H23 (MD)H33 (MD)H43 Nickel-cadmium 1.0W at 2.0W at 5.0W at battery: 10Vdc 10Vdc 10Vdc</p> <p>MODULATION: Type 16F3: For 25kHz channel spacing: ±5kHz for 100% modulation at 1000Hz (±4.0kHz min.); For 20kHz channel spacing: ±4kHz for 100% modulation at 1000Hz (±3.2kHz min.); For 12.5kHz channel spacing: ±2.5kHz for 100% modulation at 1000Hz (±2.0kHz min.); including PL modulation for PL models.</p> <p>PL MODULATION: 25kHz Channel Spacing ±1kHz max ±500Hz min 20kHz Channel Spacing ±800Hz max ±400Hz min 12.5kHz Channel Spacing ±500Hz max ±250Hz min</p> <p>AUDIO Meets CEPT requirements DISTORTION: at rated audio</p> <p>MAX. PERMISSIBLE CHANNEL SEPARATION: 6MHz (No degradation)</p> <p>FREQUENCY STABILITY: FROM -25°C to +55°C (+25°C ref.) ±.0005% (25/20kHz Channel Spacing) ±.0002% (12.5kHz Channel Spacing)</p> <p>SPURIOUS & HARMONIC FREQUENCIES: Less than: 0.25µW below 1GHz 1.0µW between 1GHz - 4GHz</p> <p>FM NOISE: At least 40dB below ±3.0kHz deviation at 1000Hz</p>	<p>AUDIO OUTPUT- Less than 5% distortion at 1kHz into rated load</p> <p>SECOND I-F FREQUENCY: 450kHz ± 1.5kHz measured at M1</p> <p>SENSITIVITY: 0.40µV max. (12dB SINAD), 0.50µV max. (20dB SINAD psophometrically weighted)</p> <p>NOISE SQUELCH SENSITIVITY: Programmable</p> <p>MAX. PERMISSIBLE CHANNEL SEPARATION: 6MHz (No degradation)</p> <p>FREQUENCY STABILITY: FROM -25°C TO +55°C (+25°C ref.) ±.0005% (25/20kHz Channel Spacing) ±.0002% (12.5kHz Channel Spacing)</p> <p>USEABLE BANDWIDTH: ±5kHz (25kHz Channel Spacing) ±4kHz (20kHz Channel Spacing) ±2.5kHz (12.5kHz Channel Spacing)</p> <p>SPURIOUS FREQUENCY REJECTION: More than 70dB below carrier</p> <p>IMAGE REJECTION: More than 70dB below carrier</p> <p>SELECTIVITY: More than 70dB at ±20/25kHz More than 60dB at ±12.5kHz</p> <p>INTERMODULATION: More than 70dB at adjacent channel</p> <p>CHANNEL SPACING: 25/20/12.5kHz</p>
	(MD)H23	(MD)H33	(MD)H43																																							
Standby:	*43mA	*43mA	*43mA																																							
Receive:	*150mA	*150mA	*150mA																																							
Transmit:	**555mA	**775mA	**1600mA																																							
Radio Only	99.0mm	(3.90")																																								
Radio with Battery																																										
Medium Capacity	161.3mm	(6.35")																																								
High Capacity	177.3mm	(6.98")																																								
Radio Only	383 g	(13.5 oz)																																								
Radio with Battery (Nickel-Cadmium)																																										
Medium Capacity	612 g	(21.6 oz)																																								
High Capacity	684 g	(24.1 oz)																																								

Specifications Subject to Change Without Notice, and Assume CEPT '84 Test Methods Except as Noted
12.5kHz Specifications Reflect CEPT '84 Methods at -10°C to +55°C.

NOTE:

- ALL BATTERIES MUST BE CHARGED PRIOR TO USE.
- USE OF CHEMICALS (DETERGENTS, ALCOHOL, AEROSOL SPRAY, PETROLEUM PRODUCTS) MAY BE HARMFUL AND DAMAGE THE RADIO HOUSING. WE RECOMMEND A MILD DISHWASHING SOAP FOR CLEANING THE EXTERIOR OF THE PRODUCT.
- O-RING SEALS MUST BE PROPERLY LUBRICATED AND ASSEMBLED TO INSURE CONFORMANCE TO MIL-810D SPECIFICATIONS FOR WATER INTRUSION.

COMPUTER SOFTWARE COPYRIGHTS

The Motorola products described in this manual may include copyrighted Motorola computer programs stored in semiconductor memories or other media. Laws in the United States and other countries preserve for Motorola certain exclusive rights for copyrighted computer programs, including the exclusive right to copy or reproduce in any form the copyrighted computer program. Accordingly, any copyrighted Motorola computer programs contained in the Motorola products described in this manual may not be copied or reproduced in any manner without the express written permission of Motorola. Furthermore, the purchase of Motorola products shall not be deemed to grant either directly or by implication, estoppel, or otherwise, any licence under the copyrights, patents or patent applications of Motorola, except for the normal non-exclusive, royalty free licence to use that arises by operation of law in the sale of a product.

Ⓜ, Motorola, Handie-Talkie, HT800, and Private-Line are trademarks of Motorola, Inc.

SAFETY INFORMATION

DO NOT hold the radio with the antenna close to, or touching, exposed parts of the body, especially the face or eyes, while transmitting. The radio will perform best if the microphone is five to eight centimeters away from the lips and the radio is vertical.

DO NOT hold the transmit (PTT) switch on when not actually desiring to transmit.

DO NOT allow children to play with any radio equipment containing a transmitter.

DO NOT operate a transmitter near unshielded electrical blasting caps or in an explosive atmosphere unless it is a type especially qualified for such use.



AEPF-17813

CMOS PRECAUTIONS

THIS RADIO CONTAINS STATIC-SENSITIVE DEVICES. DO NOT OPEN THE RADIO UNLESS PROPERLY EARTHED. TAKE THE FOLLOWING PRECAUTIONS WHEN WORKING ON THIS UNIT.

The red printed circuit boards indicate static sensitive devices are contained on these boards, and should be handled with the following precautions.

- (1) Store and transport all CMOS devices in conductive material so that all exposed leads are shorted together. Do not insert CMOS devices into conventional plastic "snow" or plastic trays used for storage and transportation of other semiconductor devices.
- (2) Ground the working surface of the service bench to protect the CMOS device. We recommend using the Motorola P/N 0180386A82 Static Protection Kit which includes a wrist strap, 2 ground cords, a table mat, and a floor mat.
- (3) Wear a conductive wrist strap in series with a 1M resistor to ground. Replacement Wrist Straps that connect to the bench top covering - Motorola P/N RSX-4015B.
- (4) Do not wear nylon clothing while handling CMOS devices.
- (5) Neither insert nor remove CMOS devices with power applied. Check all power supplies to be used for testing CMOS devices and be certain there are no voltage transients present.
- (6) When straightening CMOS pins, provide ground straps for apparatus used.
- (7) When soldering, use a earthed soldering iron.
- (8) If at all possible, handle CMOS devices by the package and not by the leads. Prior to touching the unit, touch an electrical ground to remove any static charge that you may have accumulated. The package and substrate may be electrically common. If so, the reaction of a discharge to the case would cause the same damage as touching the leads.

CAUTION

DO NOT DEPRESS THE PTT OR SIDE SWITCHES WHILE INSERTING THE FRAME INTO THE HOUSING; DAMAGE TO THE SWITCHES COULD OCCUR. FOR REASSEMBLY, USE ONLY THE TOOLS THAT ARE RECOMMENDED. USING UNAUTHORIZED TOOLS, IMPROPERLY USING AUTHORIZED TOOLS, OR FAILING TO ADHERE TO TORQUE SPECIFICATIONS MAY CAUSE IRREPARABLE DAMAGE. DO NOT ATTEMPT TO REMOVE THE ANTENNA BUSHING FROM THE CONTROL TOP; IT IS ULTRASONICALLY WELDED IN PLACE. DO NOT DESOLDER OR RESOLDER ANY CONNECTIONS BETWEEN THE VOLUME POTENTIOMETER FLEX AND THE ON/OFF-VOLUME POTENTIOMETER (37) WITH THE SWITCH IN THE OFF POSITION. MAKE SURE THAT THE SWITCH IS IN THE ON POSITION BEFORE APPLYING ANY HEAT; OTHERWISE THE INTERNAL PARTS OF THE SWITCH WILL BE DAMAGED.

SERVICE AIDS

The following table lists tools and service aids recommended for working on the HT800. While all of these items are available from Motorola, most are standard shop equipment items, and any equivalent item capable of the same performance may be substituted for the item listed.

MOTOROLA PART NO.	DESCRIPTION	APPLICATION
RTK-4205A	RIB/Radio/test set cable	Connects radio to RTX-4005B Test Box and RIB.
RTL-4226B	Battery Eliminator	Interconnects radio to power supply.
15-8036B62	Battery Adapter	Connects radio to battery eliminator without main housing.
RTL-4234A	Controller Flex Extender Fixture	Eases in troubleshooting of controller flex and RF board.
01-80370B92	Controller Flex Hold Down Fixture	Provides secure mount for controller flex during servicing.
RTX-4005B or both RTX-4005A and RPX-4665A field modification kit	Portable Test Set	Enables connection to the universal Allows switching for radio testing.
1-80353A74	Radio Interface Box	Enables communications between the radio and the computer's serial communications adapter.
EPN-4041A	Wall-mounted Power Supply (220VAC)	Used to supply power to the RIB.
EPN-4040A	Wall-mounted Power Supply (240VAC)	Used to supply power to the RIB.
30-80369B71 or 30-80369B72	Computer Interface Cable	Use B72 for the IBM PC AT. All other IBM models use B71. Connects the computer's serial communications adapter to the RIB.
NKN6376A	Cloning Cable	Allows an HT800 radio to be duplicated from a master radio by transferring programmed data from one radio to another.
EVN-4101A	Programmer/Tuner Software	Software on 5-1/4" floppy disc.
EVN-4103A	Programmer/Tuner Software	Software on 3-1/2" floppy disc.
F.A.S.T. #9	"Using the RSX-4057A Desoldering Station"	How to use the RSX-4057A to successfully remove and replace surface mount devices.

RECOMMENDED TOOL LISTS

The following table lists the tools recommended for working on the HT800; these also are available from Motorola. Note that the RSX-4057A workstation requires the use of a specific "heat focus head" for each of the components on which this item is used. **Each of these heat focus heads must be ordered separately.** The individual heat focus heads (and the components on which they are used) are listed at the end of the table.

MOTOROLA PART NO.	DESCRIPTION	APPLICATION
RSX 4043A	Torque Screwdriver	Handle for bits listed below
66-80321B86	Phillips bit	Radio screws
55-0517E01	Hex socket bit	Volume and rotary switch nuts
66-80370B95	Spanner bit	Toggle switch spanner nut
66-05106N01	Tuning tool	Tunable coils and potentiometers
66-80387A59	Extractor, 2 contact	Removal of discrete surface mounted devices.
66-80387A64	Heat controller with safety stand, or	
01-80382A31	Portable desoldering unit	
66-80375A74	0.025 replacement tip, 5/pk	For 01-803282A31 portable desoldering unit
01-80386A81	Miniature digital readout soldering station (incl. 1/64" micropoint tip)	
01-80386A81	Illuminated magnifying glass with lens attachment	
01-80386A82	Anti-static grounding kit	Used during all radio assembly and disassembly procedures
66-84253C72	Straight prober	
66-80384A98	Brush	
10-10041A86	Solder (RMA type), 63/37, .20" diameter - 1 lb. spool	
10-80370B43	RMA liquid flux	
RSX-4057A	Surface mounted component - IC removal/rework station (order all heat focus heads separately)	Removal of surface-mounted integrated circuits
HEAT FOCUS HEADS	INSIDE DIMENSIONS OF HEADS	
66-80334B48	0.318"X0.318" for U402 & U403	
66-80334B49	0.410"X0.410" for U406	
66-80334B51	0.492"X0.492" for U401 & U405	

TORQUE AND TOOL SPECIFICATIONS CHART

DESCRIPTION	SIZE	PART NUMBER	QTY.	RETIGHTEN WITH RSX-4043A TORQUE SCREWDRIVER AND	TORQUE (IN.LB.)	TORQUE IN N/METER INT'L.	EXP. VIEW NUMBER
Control Top							
Antenna Bushing Spanner		0205765L02	1	6680370B90	12	1.36	22
Volume Pot Nut	0.75x8x1.6	0205629L01	1	5505717E01	5	0.57	17
Freq. Switch Nut	0.75x8x1.6	0205629L01	1	5505717E01	5	0.57	17
Toggle Switch Spanner		0205163Q01	1	6680370B95	4	0.45	19
Control Top Screw	4-40x3/16"	0300136785	1	6680321B79	5	0.57	6
Housing							
Battery Contact Screws	2-56x5/32"	0300139982	2	6680321B86	3	0.34	45
Bottom Front Cover Screws	2-56x1/4"	0300140041	2	6680321B86	3	0.34	87
Baseplate to Frame Screws	4-40 (captive)	0305941K01	2	6680321B79	5	0.57	49
Front Cover Post Screws	4-40x5/16"	0305137Q01	2	6680321B79	5	0.57	52
Controller							
Front Shield Screw	2-56x7/16"	0300140484	1	6680321B86	2	0.23	35
Bottom Screw	2-56x5/16"	0300138620	1	6680321B86	3	0.34	67
Controller to Frame Screws	2-56x1/8"	0300140369	4	6680321B86	2	0.23	35
RF Board							
Back Shield Screws	2-56x5/16"	0300136772	4	6680321B86	3	0.34	65
RF Board Screw	2-56x5/16"	0300136772	1	6680321B86	3	0.34	not shown
PA Heatsink to PCB (1-&2-W)	2/56x3/16"	0300136771	2	6680321B86	3	0.34	15
PA Heatsink to PCB (5-W)	2-56x3/16"	0300136771	1	6680321B86	3	0.34	15
PA to Heatsink (1-& 2-W)	2-56x5/32"	0300139685	1	6680321B86	3	0.34	101
PA to Heatsink Nut (5-W)	1/4"		1		5	0.57	not shown
Synthesiser Casting Screw	2-56x3/16"	0300136771	2	6680321B56	4	0.45	15
Front Cover							
Speaker/Mic Tab Screws	2-56x5/32"	0300139982	4	6680321B86	3	0.34	45

DISASSEMBLY PROCEDURE

REFER TO DISASSEMBLY ART ON PAGE 37 (FIG. 1)

1. Turn off the radio.
2. Remove the battery:
While pushing the spring-loaded battery latch towards the top of the radio, slide the battery away from the latch, removing it from the baseplate on the bottom of the radio.
3. Remove the two screws from the back of the radio.
4. Remove the two screws on the bottom of the radio (baseplate corners).
5. Loosen the two captive screws on the bottom of the radio (middle of each end of baseplate). Do not completely remove the captive screws from the baseplate.
6. Lift the front cover from the radio housing being careful not to pull against the speaker/microphone wires.
7. Disconnect the speaker/microphone connector from the controller flex by grasping the microphone flex (near the plug) and pulling the plug straight out and away from the circuit board.
8. With a thumb and forefinger, grasp the antenna at its base and pull lightly to remove the frame assembly from the radio housing. Do not press the PTT switch during removal.

CAUTION

REFER TO "CMOS" PRECAUTIONS, PART OF "SAFETY INFORMATION SECTION."

9. Remove the screw that secures the front shield.
10. Remove the front shield by pulling it straight out and away from the radio.

11. Remove the controller circuit as follows:
(A) Remove the 4 screws (2 on each side) that secure the controller to the frame.

NOTE

Be careful to pull each connector straight out and away from the mating socket so as not to bend or break the connector pins.

- (B) Disconnect the 2 bottom flex connectors by carefully sliding them away from the bottom of the radio.
- (C) Lift the controller circuit (nearest the bottom of the radio) away from the radio just enough to gain access to the connector under the controller.
- (D) Disconnect the connector under the controller.
- (E) Disconnect the 2 connectors at the top of the controller.
- (F) Lift the controller totally away from the radio.

NOTE

Refer to the Exploded View Diagram if further disassembly is necessary.

12. Assemble the radio in the reverse order of disassembly, making certain:
 - to avoid damage to the flex circuits, connectors, and connector pins when reinserting the controller.
 - not to depress the PTT switch when sliding the circuit board back into the housing.

CAUTION

Inspect the frame O-ring and control head O-ring. Replace if obvious damage exists.

GENERAL

REFER TO ALIGNMENT LOCATIONS DIAGRAM ON PAGE 37 (FIG. 2)

THIS RADIO HAS BEEN FACTORY ALIGNED AND DOES NOT REQUIRE ANY ADJUSTMENTS. Realignment may be required if components are replaced or have aged, or if any transmitter/receiver frequencies are changed. If it is necessary to realign the radio, perform the following procedures:

1. When using the RTX-4005 test box, place the MP PL switch in the OFF position.
2. Remove the battery and front cover as described in the "DISASSEMBLY PROCEDURE."
3. Refer to the Test Set-Up Detail and connect the test equipment and Programmer/Tuner to the radio as illustrated.
4. Connect a dc power supply to the battery eliminator and attach the battery eliminator to the radio.
5. Adjust the power supply for 10.0Vdc. Set current limit to 2.0A.
6. Turn the radio off then on to reinitialise the radio.
7. Frequency Adjust (Synthesiser). Terminate the program/test cable (RTK-4205A), RF lines (pins 10 and 12), through a 30dB pad to a frequency counter or service monitor. Set the radio's frequency switch to any channel. Key the radio using the external PTT switch. Compare the frequency reading on the counter (or service monitor) to the customer frequency assigned to that channel. The frequency difference should be less than ± 750 Hz. Adjust R129 if the frequency difference is more than ± 750 Hz.
8. Perform either the "RECEIVER ALIGNMENT" procedure or "TRANSMITTER ALIGNMENT" procedure or both procedures as required.

TRANSMITTER ALIGNMENT

Review "GENERAL" information section before performing TRANSMITTER ALIGNMENT

Preliminary Adjustments:

1. Terminate the program/test cable (RTK4205A), rf lines (pins 10 and 12), to a power meter through a 30dB pad.
2. Make all measurements at the Program Test Cable (pins 10 and 12), with radio keyed through the external PTT switch.
3. Program new customer frequencies (if necessary).

STEP	ADJUST	FOR	USING	NOTE
1	Check power output on all channels. NOTE: You must dekey before changing channels for the synthesiser to change frequencies. Set the frequency switch to the channel with the lowest output power.			
2	C120 Trimmer Capacitor	Maximum power output with least current drain	RF Wattmeter and Ammeter	Reading should be greater than rated rf power output, with current drain less than 580mA (1-Watt Models), less than 800mA (2-Watt Models), or less than 1625mA (5-Watt Models). Note: Two possible peaks, choose peak with least current drain. Adjust from component side.
3	Check remaining channels	Same power and current readings obtained in STEP 2	RF Wattmeter and Ammeter	
4	Repeat steps 1 through 3 if necessary.			

Deviation Adjustment:

1. Terminate the program/test cable (RTK-4205A) through a 30dB pad to a service monitor (or deviation meter).
2. Place the **METER SELECTOR** switch on the RTX-4005 test box to the **MIC** position. Insert a 1kHz tone at the **AUDIO IN** port of the test box. Use an ac voltmeter to monitor the voltage at the **AC/DC METER** port of the test box. Using the PTT switch on the RTX-4005 box to key the radio, adjust the level of the 1kHz tone until 45mV is present at the **AC/METER** port. Dekey the radio.
3. Connect the program/test cable to the Radio Interface Box (RIB). Use the Programmer/Tuner to read the radio.
4. If the radio requires a change in frequency or options, make the appropriate changes to the personality file and program the radio.
5. Enter the **RADIO ALIGNMENT** and **SERVICE AIDS** menu from the main menu. Select the **TUNE CHANNEL** option.
6. Set the frequency switch on the radio's control top for the channel to be adjusted.
7. Proceed to the **VCO MODULATION LEVEL** position of the **TUNE CHANNEL** screen.
8. Press and hold down the PTT switch on the RTX-4005 to continuously key the radio.
9. Press the \pm keys to tune for a peak deviation as shown in the table below for the radio's appropriate channel spacing.
10. Release the PTT switch on the RTX-4005 to dekey the radio.
11. Proceed to the **REF OSCILLATOR LEVEL** position of the **TUNE CHANNEL** screen.
12. Disconnect the 1kHz tone from the **AUDIO IN** port of the RTX-4005.
13. Press and hold down the PTT switch on the RTX-4005 to continuously key the radio.
14. Press the \pm keys to tune for a peak deviation as shown in the following table for the radio's appropriate channel spacing.
15. Release the PTT switch on the RTX-4005 to dekey the radio.
16. Reconnect the 1kHz tone to the **AUDIO IN** port of the RTX-4005.
17. Repeat steps 6-16 for all channels to be tuned.
18. Exit from the **TUNE CHANNEL** menu and program the radio.
19. With the 1kHz tone applied, check the total transmit deviation to the range shown in the following table. Repeat the above procedure to retune any of the channels if necessary.
20. The programmer disables normal transmit (5-tone or PL encode) while on the **REF OSCILLATOR LEVEL** operation, and forces the radio to encode 30Hz PL regardless of radio settings.
21. If any changes to the deviation levels were necessary, the radio must be reprogrammed.

CH SPACING

25kHz
20kHz
12.5kHz

VCO MODULATION

STEP 9
4.5-4.8kHz
3.5-3.8kHz
2.25-2.40kHz

STEP 19
4-5kHz
3.2-4kHz
2-2.5kHz

REF MODULATION

STEP 14
670-730Hz
590-650Hz
300-350Hz

NOTE

While in the TUNE CHANNEL Screen, changes to the deviation settings are made in the radio's RAM. If the radio is dekeyed during the deviation adjustment, the radio's original information will be returned to RAM. To place the programmer settings back into RAM, press either the ENTER, +, or - key.

Deviation Adjustment DTMF Radios:

1. Follow the deviation procedure detailed above, but in step 14, adjust for the VCO MODULATION LEVEL as shown in the table below for the radio's appropriate channel spacing.
2. Press the number 1 key on the DTMF pad and continuously key the radio using the radio's PTT switch. Adjust R709 for the deviation defined in the table below for the radio's appropriate channel spacing.

CH. SPACING

25kHz
20kHz
12.5kHz

STEP 1

4.7-4.9kHz
3.7-3.9kHz
2.35-2.45kHz

STEP 2

3.0-3.2kHz
2.4-2.6kHz
1.5-1.7kHz

NOTE

DTMF memory is volatile. If the battery is left off for more than 2 minutes the memory will be erased.

RECEIVER ALIGNMENT

Preliminary Adjustments:

1. The receiver is factory tuned to operate over the entire bandsplit and should not need retuning. Perform the "Receiver Check" to determine if "RECEIVER ALIGNMENT" (tuning any portion of the receiver) is necessary.
2. Connect the program/test cable (RTK-4205A) to the Radio Interface Box (RIB). Use the Programmer/Tuner to read the radio.
3. Enter the Per Radio menu in the Programmer/Tuner. Disable the battery saver by pressing the space bar. Exit from the Per Radio menu, and then program the radio.
4. When using the RTX-4005 test box, place the **AUDIO OUT** switch in the **B** position to set for proper speaker loading. Place the meter selector in the **AUDIO PA** position for receiver tests.
5. Connect the rf cable of the test cable to an rf generator or service monitor.

Receiver Check:

1. Use the Programmer/Tuner to program for new customer frequencies, if necessary.
2. Set the rf generator (or service monitor) for the appropriate frequency at a 1mV level with a 1kHz tone modulated at 3kHz deviation.
3. Connect the **AC/DC METER** port of the RTX-4005 to an ac voltmeter. Adjust the volume potentiometer (R140) for an ac voltmeter reading of 4.47Vrms.
4. Connect a SINAD meter to the **AC/DC METER** port of the RTX-4005.
5. Reduce the rf level until 12dB of SINAD is obtained; record the rf level reading. Depress the monitor button while taking this measurement to ensure that the radio is not squelched. Also temporarily disconnect the test cable from the RIB to ensure that computer noise does not affect the measurement.
6. Perform SINAD measurements on all channels.
7. If the rf level required to produce 12dB SINAD is 0.40V or less, *DO NOT REALIGN THE RECEIVER*; instead, proceed directly to "Squelch Sensitivity/Check Adjustment." If the rf level required to produce 12dB SINAD is greater than 0.25 μ V, perform the "Receiver Alignment."

Receiver Alignment (Back End):

DO NOT PERFORM RECEIVER ALIGNMENT UNTIL THE "RECEIVER CHECK" HAS BEEN PERFORMED.

NOTE

The receiver back end coils L6, L7, and L8, and the receiver front end coils L1, L3, L4 and L5 are factory tuned to cover the entire bandsplit and should not need retuning. Should the rf amp, mixer, crystal filters, i-f module, or accompanying parts need replacing, it may be necessary to perform the following tuning procedure:

Receiver Alignment (Back End):

1. Remove the radio from its housing as described in the "DISASSEMBLY PROCEDURE," then remove the backplane shield (exploded view item #74).
2. Attach the battery adapter to the radio frame, then attach the battery eliminator to the battery adapter.
3. Selecting any one of the customer frequencies, adjust the rf generator or service monitor for the appropriate frequency. Then, place the radio front side down so that the solder side (side 2) of the PC board is facing up.
4. Tune coils L6, L7, and L8 flush with the solder side of the PC board.
5. With an ac voltmeter, monitor M1 on the solder side of the PC board. Set the ac voltmeter to the -40dB scale, and adjust the rf level so that the voltage can be monitored at M1. During the following procedure, adjust the rf level to keep the ac voltage at M1 within the -40dB scale.
6. Peak coils L6, L7, and L8 (in that order) for maximum ac voltage at M1.
7. Perform the "Receiver Check" procedure, then repeat steps 4-6 of the "Back End" procedure, if necessary.

NOTE

Perform the following procedure only if the radio fails the "Receiver Check," and the receiver back end alignment has been performed. The radio should already be removed from the housing.

Narrow bandwidth (6MHz or less)

8. Tune coils L1, and L3 through L8 flush with the solder side (size 2) of the PC board.
9. Set the radio to the highest customer receive frequency, then adjust the rf generator or service monitor for the appropriate frequency.
10. With an ac voltmeter, monitor M1 on the controller flex. Set the ac voltmeter to the -40dB scale and adjust the rf level so that the ac voltage can be read at M1. During the following procedure, adjust the rf level to keep the ac voltage at M1 within the -40dB scale.
11. Adjust L3, then L5 for the maximum ac voltage level at M1.
12. Set the radio to the lowest customer receive frequency, then adjust the rf generator or service monitor to the appropriate frequency and level.
13. Adjust L4, then L1 for the maximum ac voltage level at M1.
14. Perform the "Receiver Alignment (Back End)" procedure and then the "Receiver Check."

Wide Bandwidth (Greater than 6MHz)

15. Tune coils L1, and L3 through L8 flush with the solder side (side 2) of the PC board.
16. Use the Programmer/Tuner to program the receiver frequency for 158.125 ± 0.1 MHz for mid split radios (146-162MHz), or 170.125 ± 0.1 MHz for high split radios (157-174MHz). If interference is present, program for a receive frequency as close to the desired frequency as possible.
17. Adjust L3, then L5 for the maximum ac voltage level at M1. Select the peak where the slugs of the coils are closest to the solder side of the PC board.
18. Use the Programmer/Tuner to program the receiver frequency for 161.975 ± 0.1 MHz for mid split radios (146-162MHz), or 173.975 ± 0.1 MHz for high split radios (157-174MHz).
19. Adjust L4 for the maximum ac voltage level at M1. Select the peak where the slug of the coil is closest to the solder side of the PC board.
20. Use the Programmer/Tuner to program the receiver frequency for $146.125 \pm$ MHz for mid split radios (146-162MHz), or 157.125 ± 0.1 MHz for high split radios (157-174MHz).
21. Adjust L1 for the maximum ac voltage level at M1. Select the second peak where the slug of the coil is farthest from the solder side of the PC board.
22. Program the radio back to the original customer receiver frequencies.
23. Perform the "Receiver Alignment (Back End)" procedure and then the "Receiver Check."

Squelch Sensitivity Check/Adjustment:

1. Use the Programmer/Tuner to read the radio, then proceed to the **RADIO ALIGNMENT** and **SERVICE AIDS** menu from the main menu. Next, select the **TUNE RADIO** operation.
2. Set the frequency switch for the channel determined to have the poorest sensitivity on the "Receiver Check." Place the decode select switch to the carrier squelch position.
3. Connect an ac voltmeter to the **AC/DC METER** port of the RTX-4005.
4. Set the rf generator or service monitor for the appropriate frequency and no modulation. Reduce the rf level to a minimum, then turn the rf off.
5. Depress the monitor button on the side of the radio and adjust the noise level for 2.2Vrms. Make a note of the level on the dB scale. This will be the reference level for quieting measurements.
6. Proceed to the **TONE SQUELCH** position in the **TUNE RADIO** screen.
7. Turn the rf of the generator or service monitor on at the minimum possible level. Increase the rf level until squelch break occurs. Note the quieting level at squelch break. If squelch break occurs between 6 and 12dB of quieting proceed directly to the carrier squelch check in step 10. If the quieting level is not within the 6 to 12dB range, continue on with step 8.
8. Press the \pm keys to adjust the tone squelch setting to 0. Adjust the rf level for 6dB of quieting.
9. Holding the rf level constant, press the + key to increment the tone squelch setting one step at a time until the radio squelches. This will be the tone squelch setting.
10. Reduce the rf level to minimum and turn the rf off. The radio should be squelched.
11. Proceed to the **CARRIER SQUELCH** position in the **TUNE RADIO** screen.
12. Turn the rf of the generator or monitor on at the minimum possible level. Increase the rf level until squelch break occurs. Note the quieting level at squelch break. If squelch break occurs between 8 and 14dB of quieting proceed directly to step 15. If the quieting level is not within the 8 to 14dB range, continue with step 13.
13. Press the \pm keys to adjust the carrier squelch setting to 0. Adjust the rf level for 8dB of quieting.
14. Holding the rf level constant, press the + key to increment the carrier squelch setting one step at a time until the radio squelches. This will be the carrier squelch setting.
15. Exit from the **RADIO ALIGNMENT** and **SERVICE AIDS** menu.
16. If the squelch settings required modification, program the radio.

Cloning Procedure:

(The content of radio A is to be duplicated into radio B)

1. Connect the cloning cable (NKN6376A) to the Universal Connector of both radio A and radio B.
2. Turn off radio A and turn on radio B.
3. Place the decode select switch on radio A to the coded squelch position () for partial cloning. Cloning will duplicate the content of radio A to radio B, except for the deviation and squelch settings.
4. Simultaneously depress the PTT and monitor button on radio A and hold.
5. Turn on radio A. The green LED on radio B will flash indicating cloning is in progress.
6. Cloning is complete once the green LED turns off and an alert tone is heard from radio B. Release both the PTT and monitor button on radio A.

DISASSEMBLY ART (FIGURE 1)

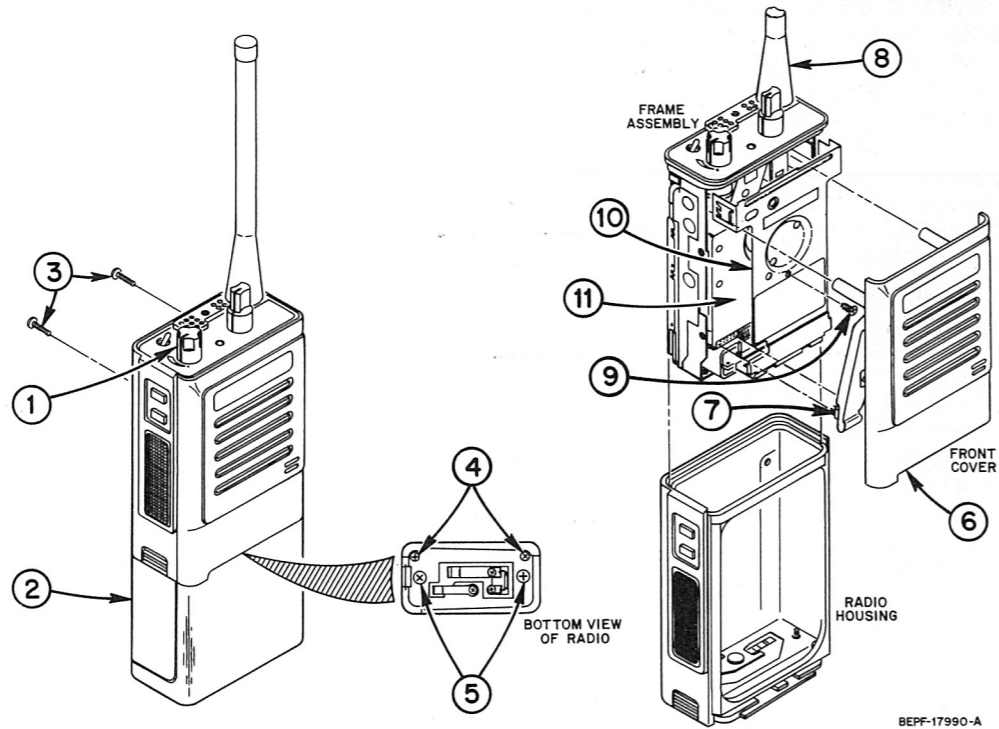

UNIVERSAL CONNECTOR DETAIL AND PIN NUMBER ASSIGNMENT

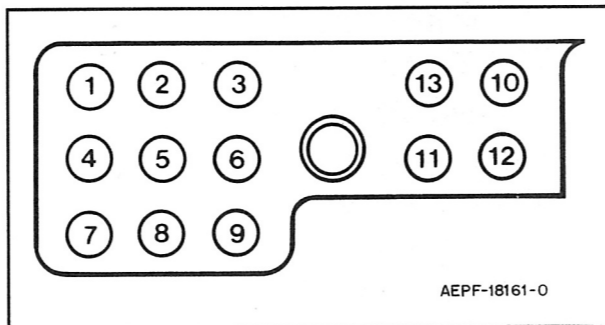

- | | |
|-----------------------------------|--------------------------------|
| 1 EXTERNAL MICROPHONE | 7 EXTERNAL SPEAKER SELECT |
| 2 EXTERNAL SPEAKER | 8 SPEAKER COMMON |
| 3 OPTION B + | 9 BUSY |
| 4 EXTERNAL PTT | 10 REMOTE ANTENNA |
| 5 GROUND
(to Controller Board) | 11 NOT USED |
| 6 DATA | 12 RF GROUND (to Mother Board) |
| | 13 SENSE |

M1 METERING POINT LOCATION (CONTROLLER)

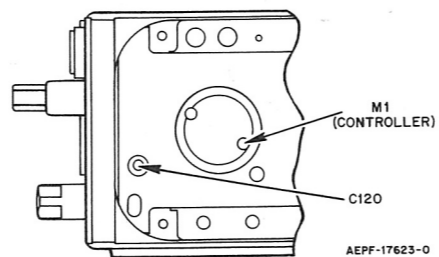

TEST SET-UP DETAIL

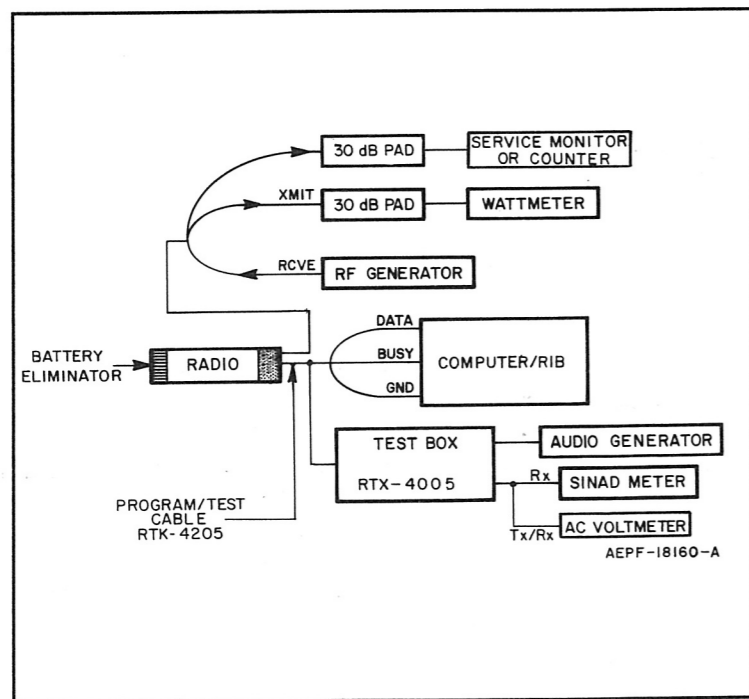

ALIGNMENT ADJUSTMENT LOCATIONS (FIGURE 2)
1- AND 2-WATT RADIOS

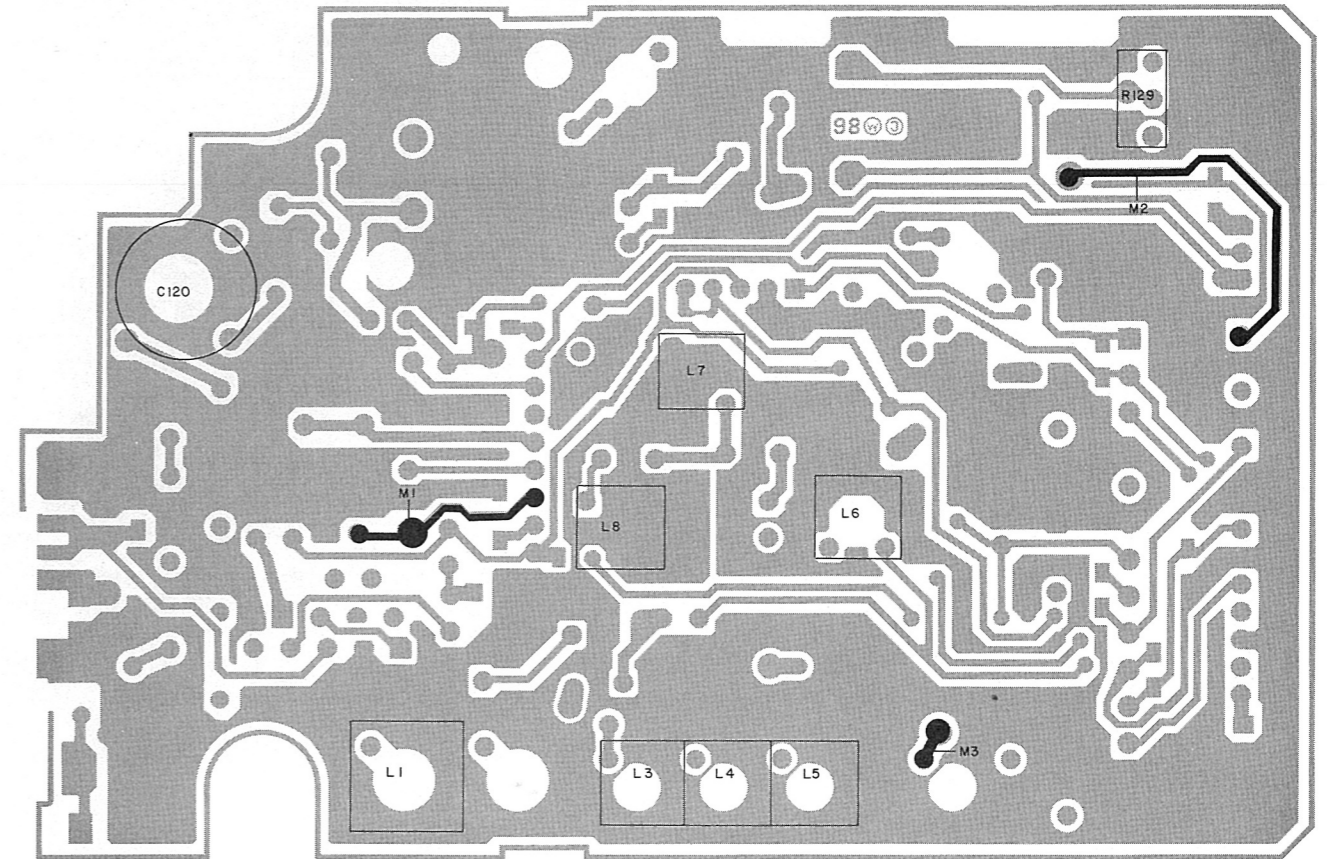

5-WATT RADIOS

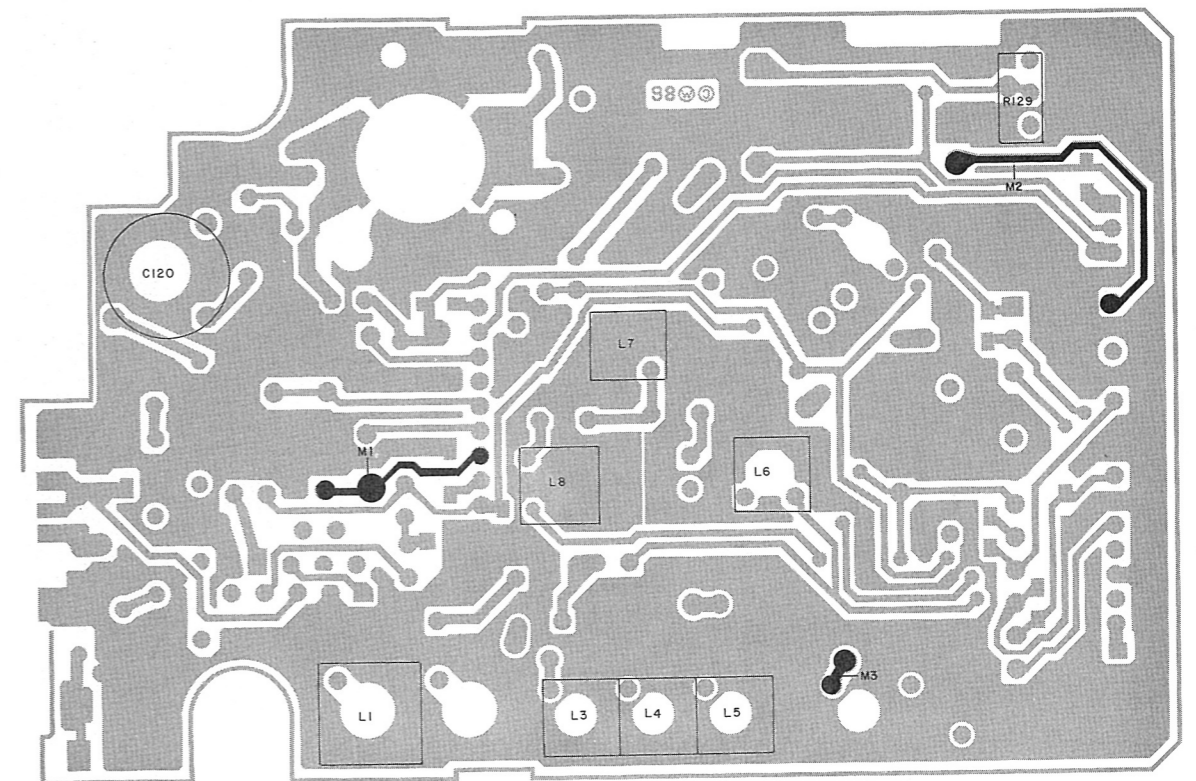

1-WATT AND 2-WATT RADIOS

SCHEMATIC AND CIRCUIT BOARD NOTES

- UNLESS OTHERWISE STATED, RESISTANCES ARE IN OHMS ($k=1000$), CAPACITANCES LESS THAN 1 ARE IN MICROFARADS, AND CAPACITANCES 1 OR GREATER ARE IN PICOFARADS.
- DC VOLTAGES ARE MEASURED FROM POINT INDICATED TO CHASSIS GROUND USING MOTOROLA DC MULTIMETER OR EQUIVALENT. TRANSMITTER MEASUREMENTS SHOULD BE MADE WITH A $1.2\mu\text{H}$ RF CHOKE IN SERIES WITH VOLTAGE PROBE TO PREVENT CIRCUIT LOADING.
- REFERENCE DESIGNATIONS ARE ASSIGNED IN THE FOLLOWING MANNER:
 UNITS SERIES = RECEIVER
 100 SERIES = TRANSMITTER
 200 SERIES = VCO & SYNTHESIZER
 300 SERIES = MISCELLANEOUS
 400 SERIES = CONTROLLER FLEX
 700 SERIES = DTMF
 800 SERIES = SIGNALLING
- INTERCONNECT TIE POINT LEGEND:
 (A) B+ TO MOTHER BOARD
 (B) CONTROLLER FLEX B+
 (5V REG) REGULATED 5V
 (D) TO DTMF CIRCUIT
 (M1) METERING POINTS M1, M2, M3
 (R) RECEIVE 10V
 (R5) RECEIVE 5V
 (S) TO SYNTHESIZER BOARD
 (T) TRANSMIT 10V
 (T5) TRANSMIT 5V
 (T) TO CONTROLLER FLEX
 (U) TO UNIVERSAL CONNECTOR
 (*) TO FRONT COVER
 (V1) REGULATED 8V

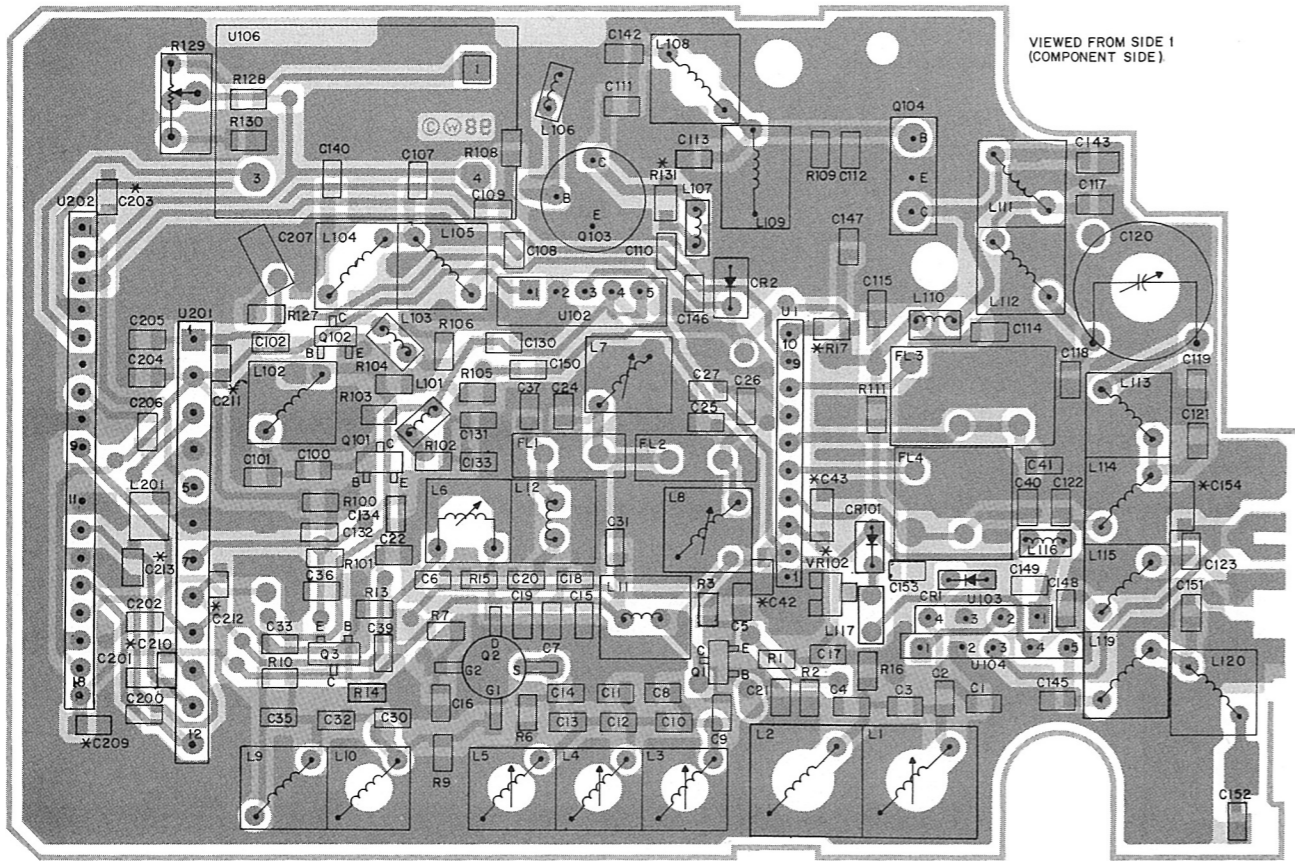

* MOUNTED ON SOLDER SIDE

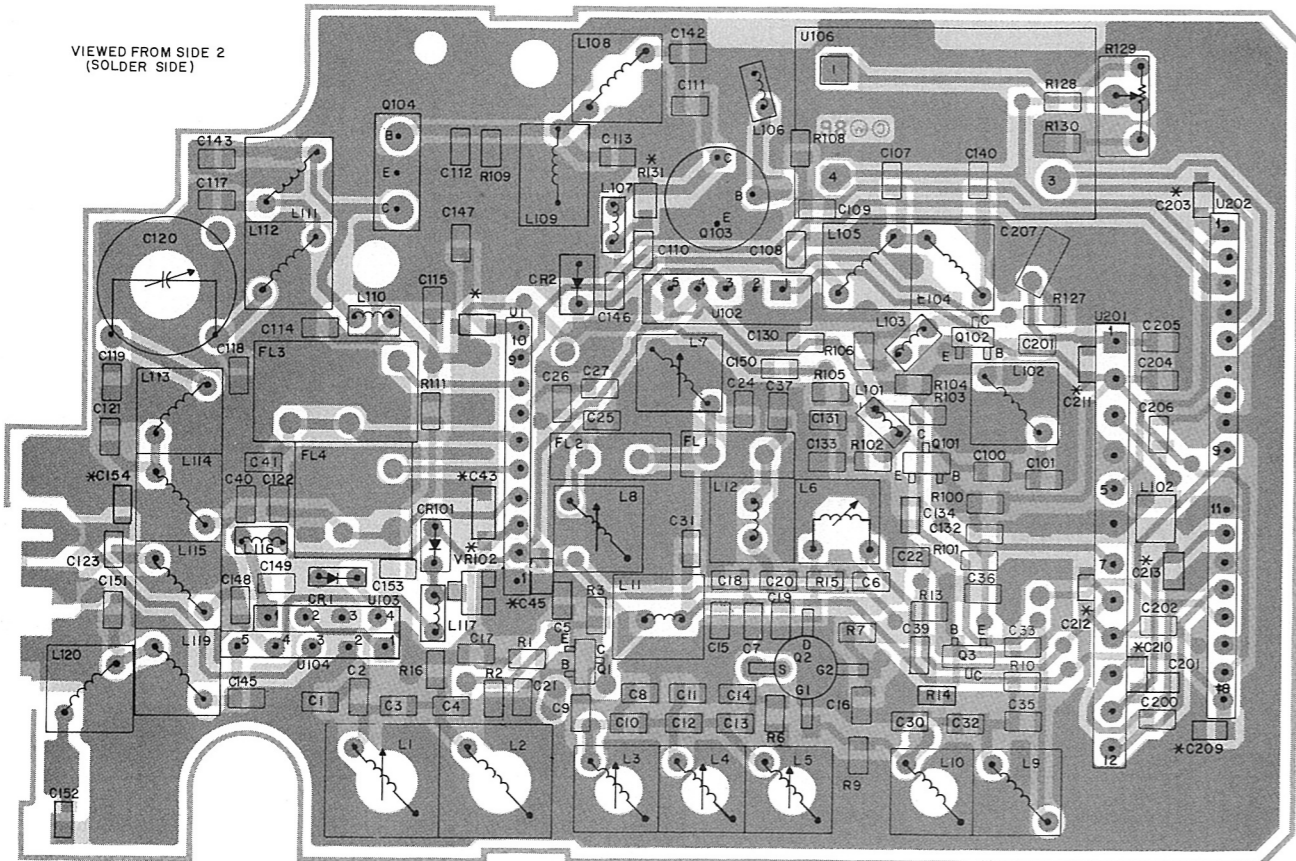

* MOUNTED ON SOLDER SIDE

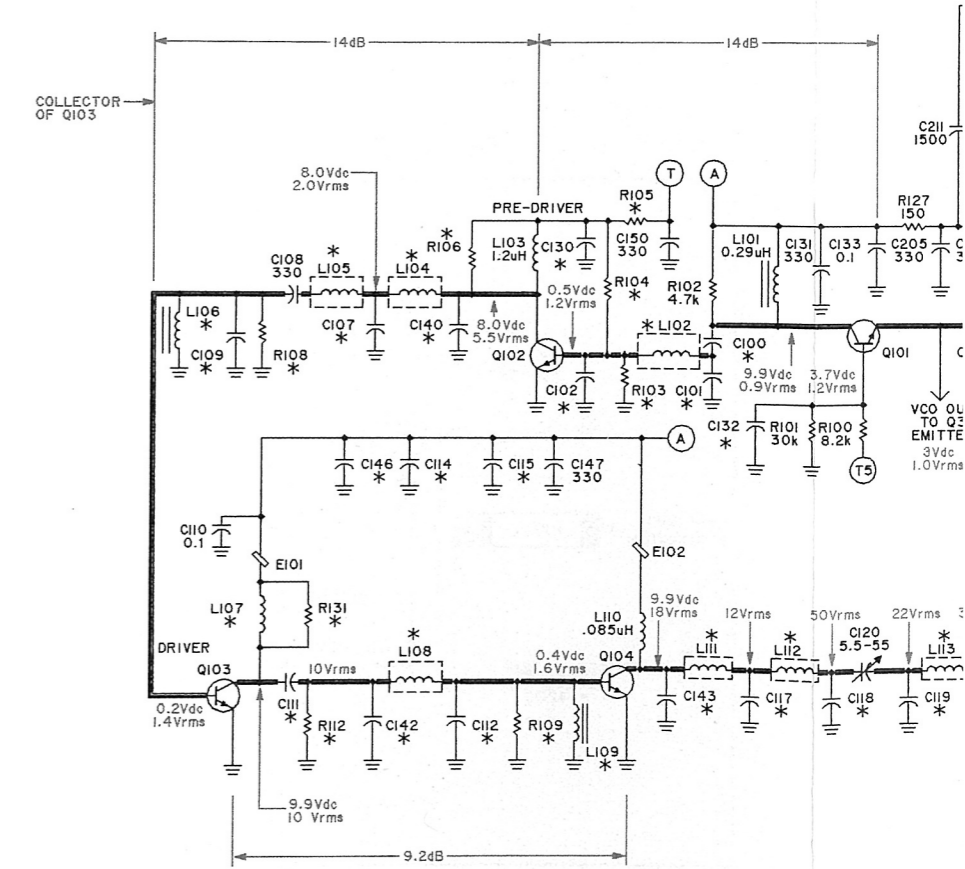
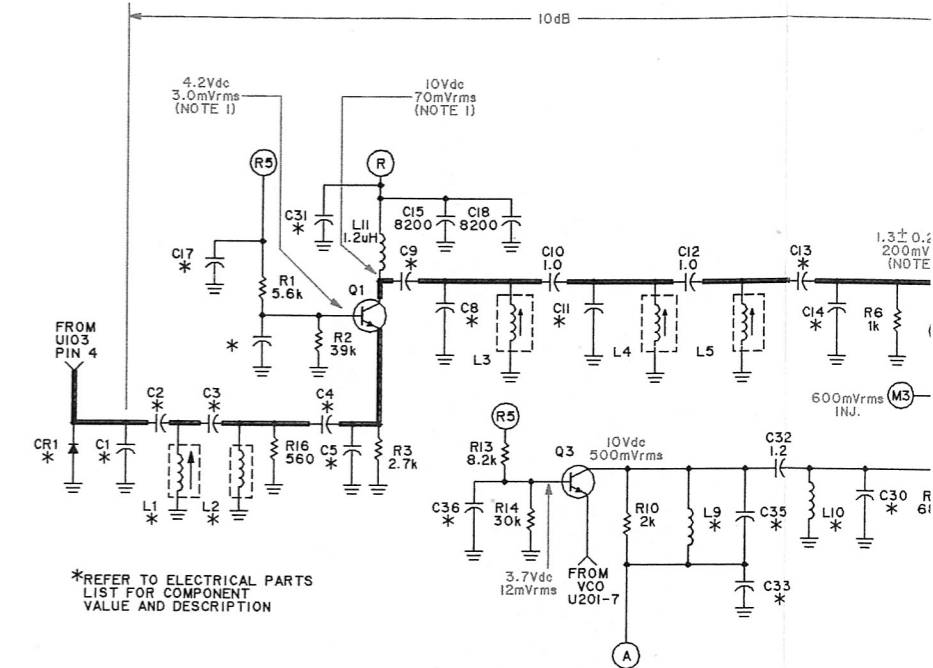

VOLTAGE OVERLAY AND WAVEFORM NOTES

- AC VOLTAGE READINGS IN dBm ARE MADE VIA A 1pF CAPACITOR INTO THE 50 OHM ADAPTER OF AN RF mV METER. RX READINGS ARE MADE WITH -20dBm CARRIER SIGNAL INTO REMOTE PORT. TX READINGS MADE WITH REMOTE PORT INTO 50 OHMS .
- AC VOLTAGE READINGS IN mV ARE MADE VIA A HIGH IMPEDANCE RF mV METER.
- THESE READINGS OBTAINED BY S/C BASE OF Q102 TO GROUND.
- THIS READING IS OBTAINED BY PUTTING A 47 OHM RESISTOR ACROSS C31 TO REDUCE LOW INJECTION FEED THROUGH.

2-LAYER CIRCUIT BOARD COPPER DETAIL VIEWING COPPER STEPS AT EDGE OF BOARD IN PROPER LAYER SEQUENCE.

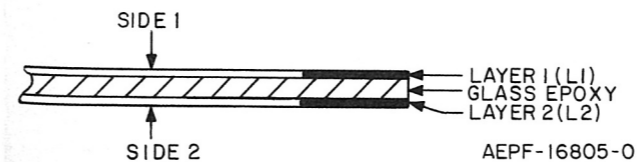

SCHEMATIC AND CIRCUIT BOARD NOTES

- UNLESS OTHERWISE STATED, RESISTANCES ARE IN OHMS (k=1000), CAPACITANCES LESS THAN 1 ARE IN MICROFARADS, AND CAPACITANCES 1 OR GREATER ARE IN PICOFARADS.
- DC VOLTAGES ARE MEASURED FROM POINT INDICATED TO CHASSIS GROUND USING MOTOROLA DC MULTIMETER OR EQUIVALENT. TRANSMITTER MEASUREMENTS SHOULD BE MADE WITH A 1.2μH RF CHOKE IN SERIES WITH VOLTAGE PROBE TO PREVENT CIRCUIT LOADING.
- REFERENCE DESIGNATIONS ARE ASSIGNED IN THE FOLLOWING MANNER:
 UNITS SERIES = RECEIVER
 100 SERIES = TRANSMITTER
 200 SERIES = VCO & SYNTHESIZER
 300 SERIES = MISCELLANEOUS
 400 SERIES = CONTROLLER FLEX
 700 SERIES = DTMF
 800 SERIES = SIGNALLING

4. INTERCONNECT TIE POINT LEGEND:

- (A) B+ TO MOTHER BOARD
- (B) CONTROLLER FLEX B+
- (5V REG) REGULATED 5V
- (D) TO DTMF CIRCUIT
- (M1) METERING POINTS M1, M2, M3
- (R) RECEIVE 10V
- (R5) RECEIVE 5V
- (S) TO SYNTHESIZER BOARD
- (T) TRANSMIT 10V
- (T5) TRANSMIT 5V
- (T) TO CONTROLLER FLEX
- (U) TO UNIVERSAL CONNECTOR
- (*) TO FRONT COVER
- (V1) REGULATED 8V

VOLTAGE OVERLAY AND WAVEFORM NOTES

- AC VOLTAGE READINGS IN dBm ARE MADE VIA A 1pF CAPACITOR INTO THE 50 OHM ADAPTER OF AN RF mV METER. RX READINGS ARE MADE WITH -20dBm CARRIER SIGNAL INTO REMOTE PORT. TX READINGS MADE WITH REMOTE PORT INTO 50 OHMS.
- AC VOLTAGE READINGS IN mV ARE MADE VIA A HIGH IMPEDANCE RF mV METER.
- THESE READINGS OBTAINED BY S/C BASE OF Q102 TO GROUND.
- THIS READING IS OBTAINED BY PUTTING A 47 OHM RESISTOR ACROSS C31 TO REDUCE LOW INJECTION FEED THROUGH.

2-LAYER CIRCUIT BOARD COPPER DETAIL VIEWING COPPER STEPS AT EDGE OF BOARD IN PROPER LAYER SEQUENCE.

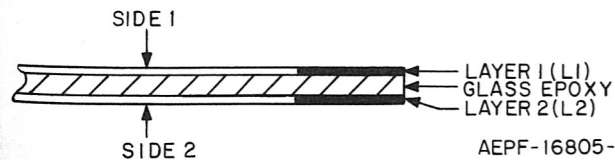

ITEMS REVISIONS CHART

ITEM NO.	FREQ. (MHz)	POWER OUTPUT	SUFFIX	CHANNEL SPACING
NUD6972A	146-162	5W		20/25kHz
NUD6973A	157-174	5W		20/25kHz
NUD6962A	146-162	1W/2W		20/25kHz
NUD6963A	157-174	1W/2W		20/25kHz
NUD6902A	146-162	5W		12.5kHz
NUD6903A	157-174	5W		12.5kHz
NUD6892A	146-162	1W/2W		12.5kHz
NUD6893A	157-174	1W/2W		12.5kHz

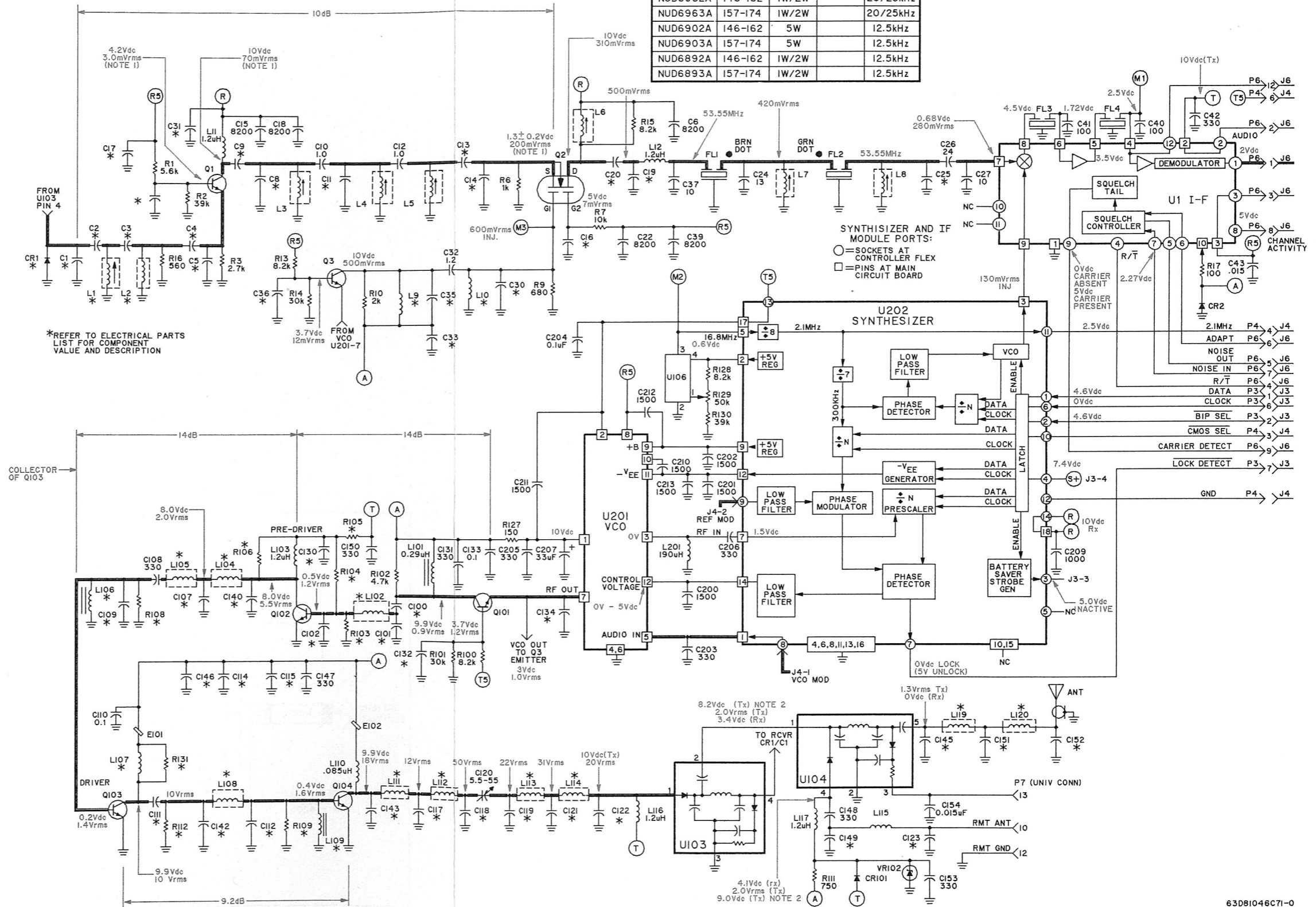

38 TRANSCEIVER SCHEMATIC DIAGRAM (1-W, 2-W, & 5-W RADIOS) AND MAIN CIRCUIT BOARD COMPONENT LOCATION DIAGRAMS (1-W AND 2-W RADIOS)

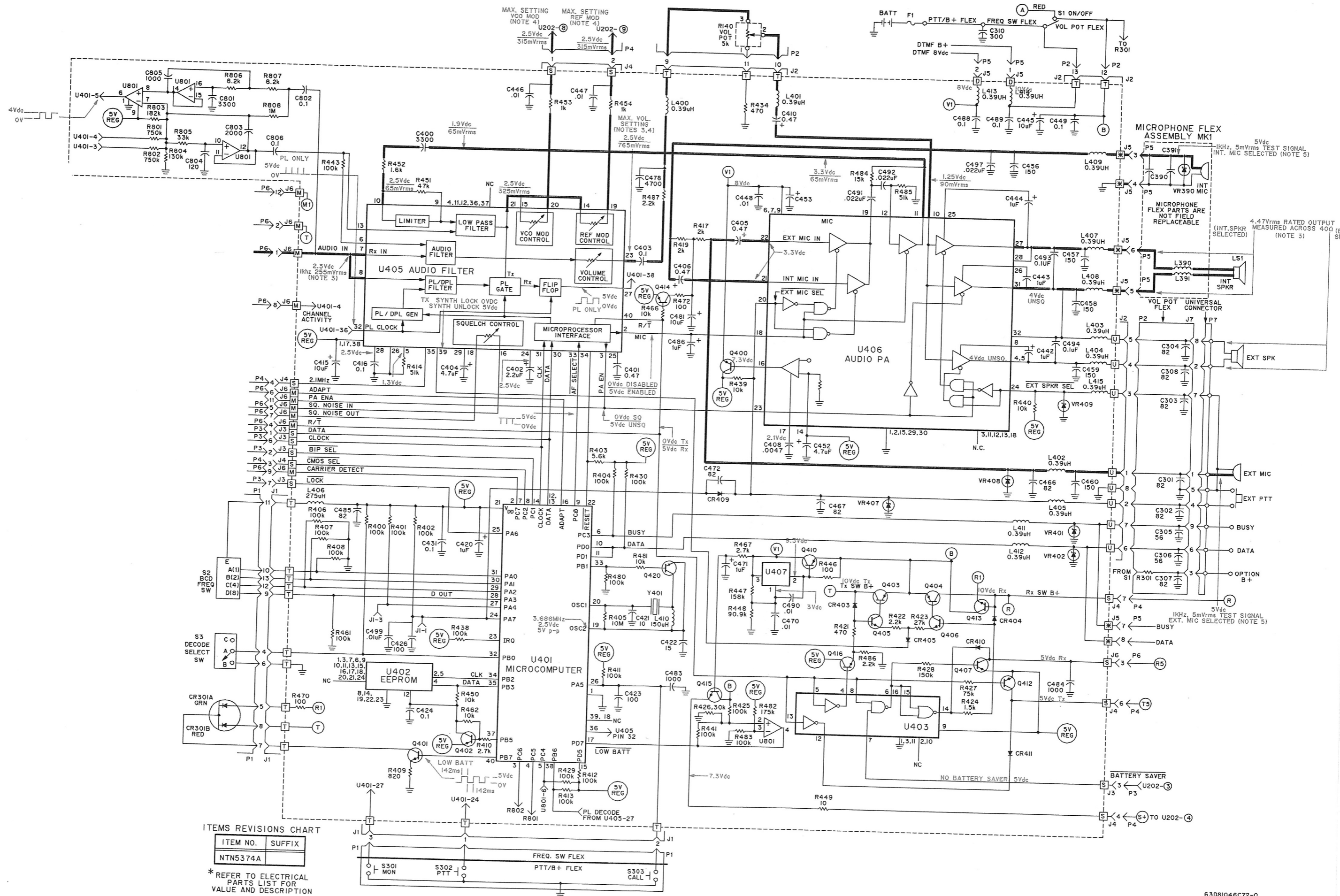

ITEMS REVISIONS CHART

ITEM NO.	SUFFIX
NTN5374A	

* REFER TO ELECTRICAL PARTS LIST FOR VALUE AND DESCRIPTION

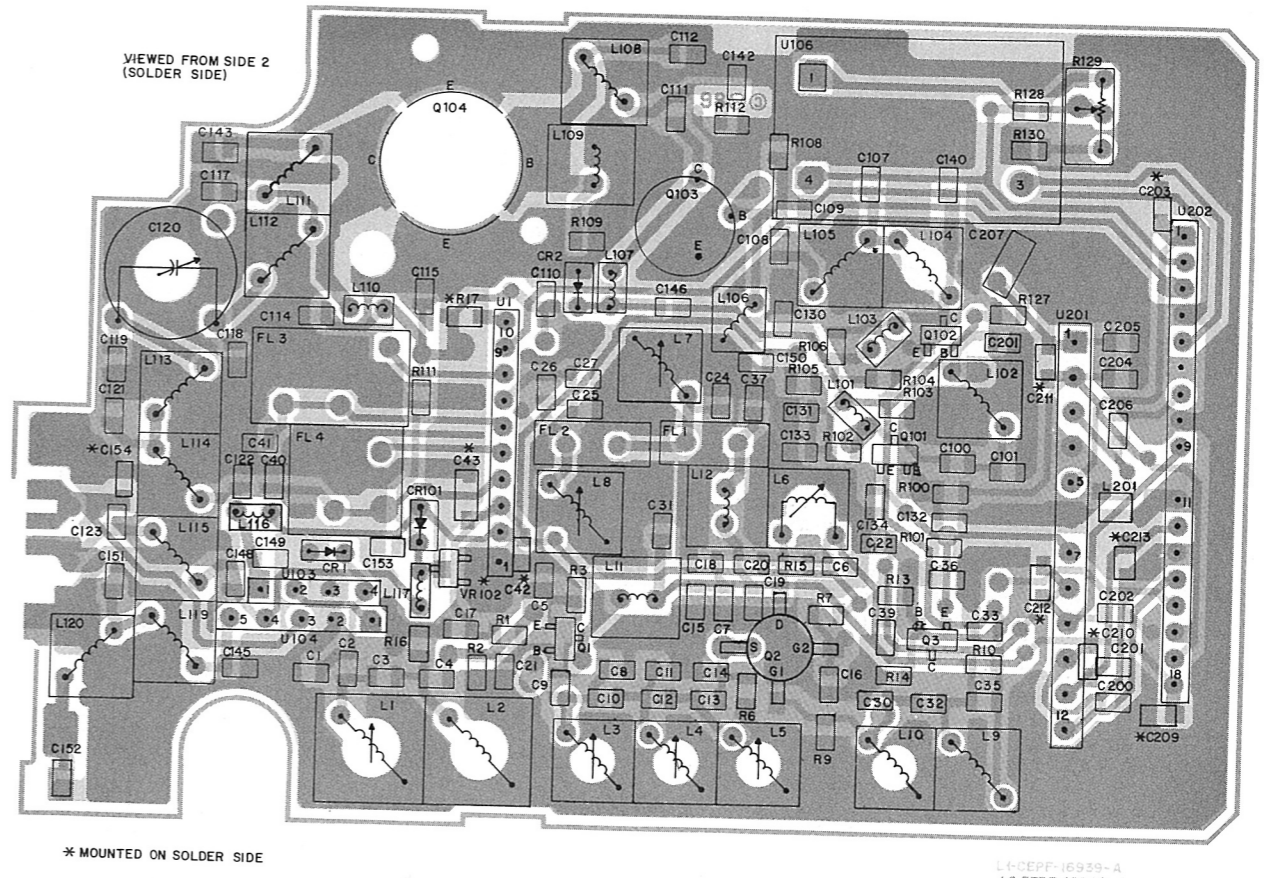
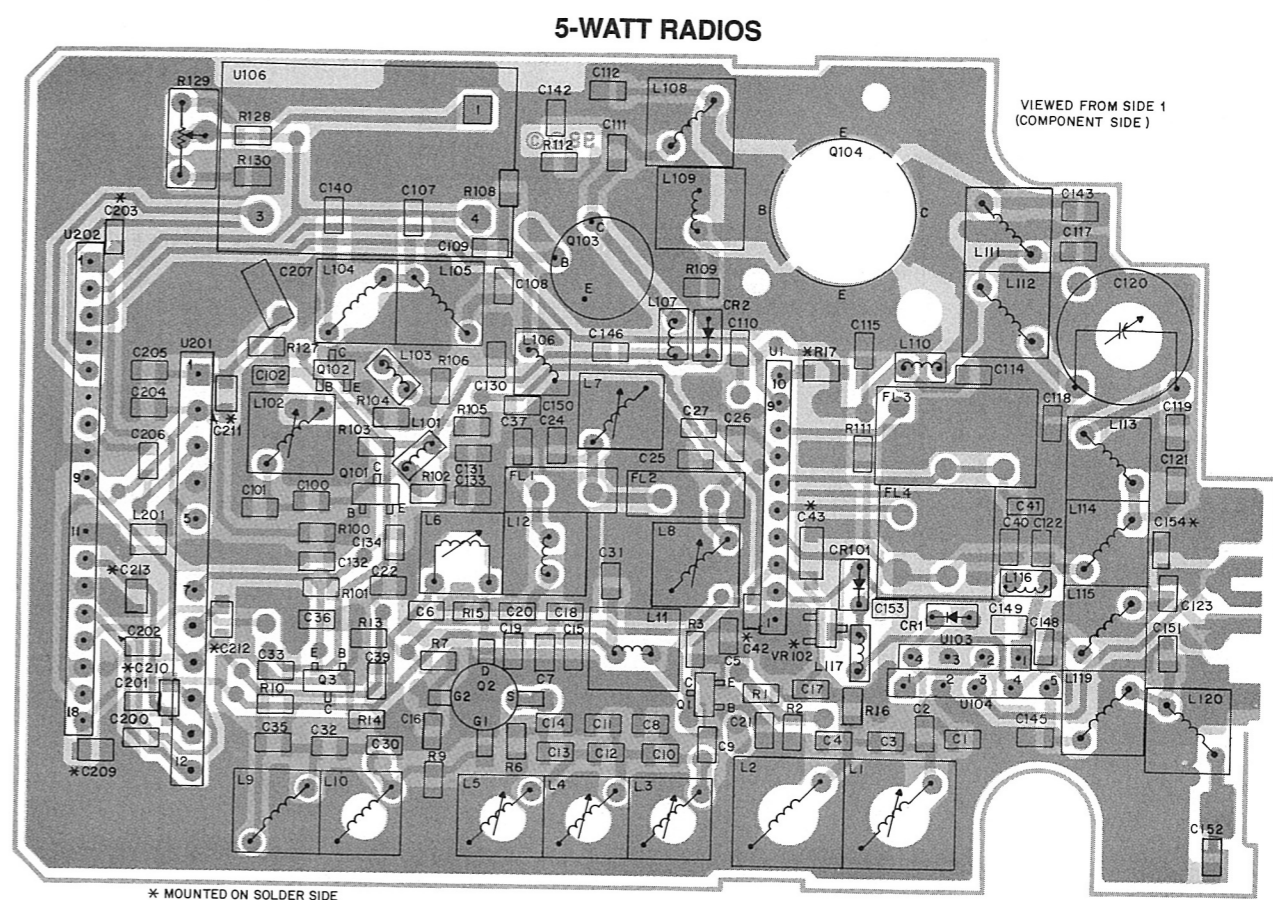
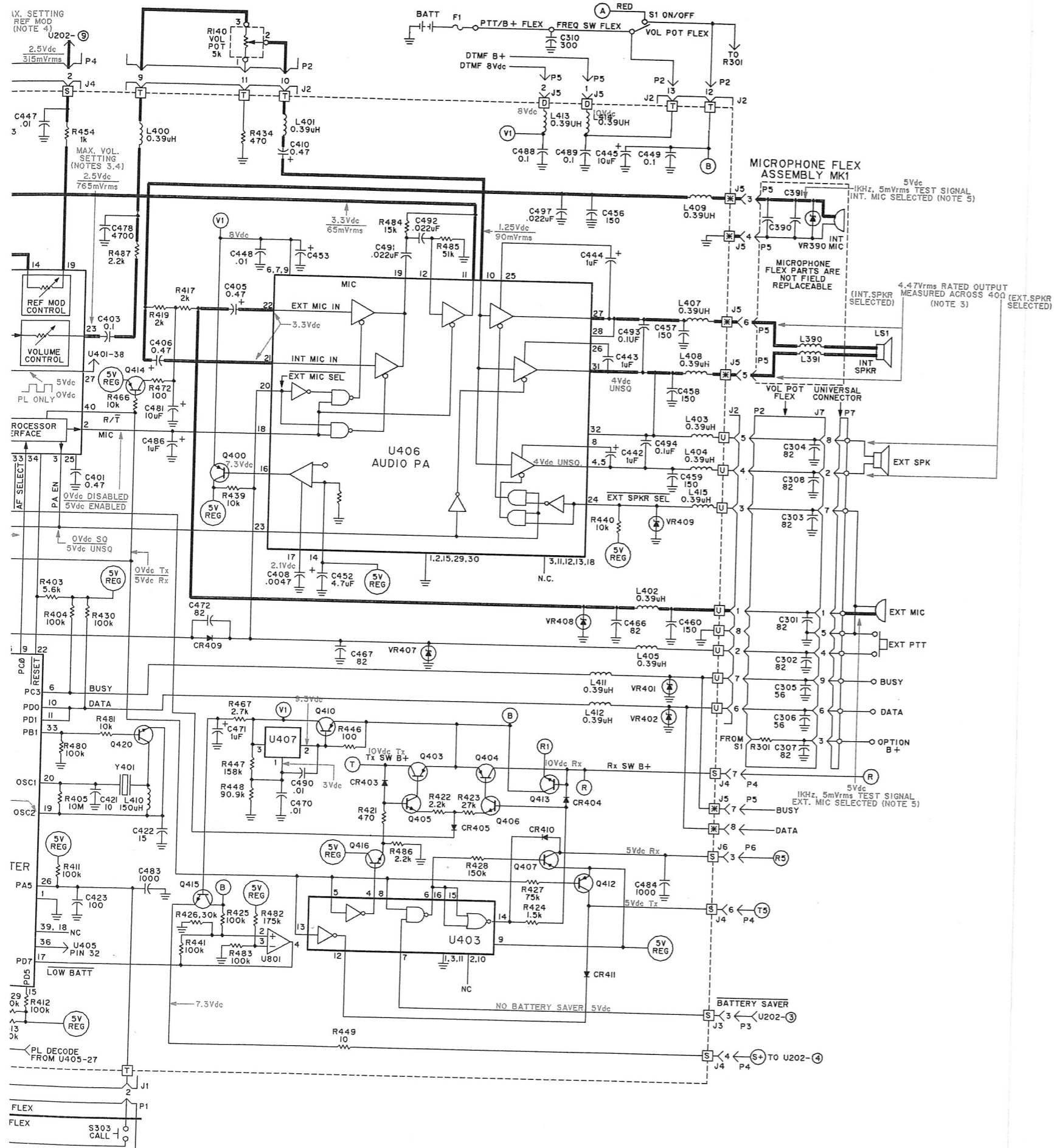

**CONTROLLER FLEX SCHEMATIC DIAGRAM AND
MAIN CIRCUIT BOARD COMPONENT LOCATION DIAGRAMS (5-W RADIOS)**

Electrical Parts List
M = 146-162MHz
H = 157-174MHz

TPLF-3554-O

REFERENCE SYMBOL	MOTOROLA PART NO.	DESCRIPTION
		CAPACITOR, Fixed: pF±5% 50V unless stated
C1	2160520B14	36 ±0.25pF (M)
C2	2160520B09	27 (H)
C3	or 2160520A23 2160520A17	22 (M) 8.2 ± 0.25pF (H) 4.7 ± 0.25pF (M)
C4	or 2160520A11 2160520B07	2.7 ± 0.25pF (H) 18 (M)
C5	or 2160520B06 2160520B05	16 (H) 15 (M)
C6	or 2160520B06 2160520A24	16 (H) 8200
C8	2160520A20	6.2 ± 0.25pF (M)
C9	or 2160520A20 2160520C21	6.2 ± 0.25pF (H) 680 (M)
C10	or 2160521C11 2160520A01	680 ±10% (H) 1.0 ± 0.25pF
C11	2160520A20	6.2 ± 0.25pF (M)
C12	or 2160520A21 2160520A01	6.8 ± 0.25pF (H) 1.0 ± 0.25pF
C13	2160520B03	12 (M)
C14	or 2160520B04 2160520B01	13 (H) 10 (M)
C15	or 2160520S02 2160520A24	11 (H) 8200
C16, 17	2160520C21	680 (M)
C18	or 2160521C11 2160520A24	680 ±10% (H) 8200
C19	2160523F22	39 (M)
C20	or 2160523F44 2160520A17	43 (H) 4.7 ± 0.25pF (M)
C21	or 2160520A23 2160520C21	8.2 ± 0.25pF (H) 680 (M)
C22	or 2160521C11 2160521A24	680 ±10% (H) 8200
C24	2160523F45	13
C25	2160523F40	2.7 ± 0.25pF (M)
C26	or 2160523F06 2160520B10	3 (H) 24
C27	2160523F15	10
C30	2160520A19	5.6 ± 0.25pF (M)
C31	or 2160520A23 2160520C21	8.2 ± 0.25pF (H) 680 (M)
C32	or 2160521C11 2160520A03	680 ±10% (H) 1.2 ± 0.25pF
C33	2160520C21	680 (M)
C35	or 2160521C11 2160520A20	680 ±10% (H) 6.2 ± 0.25pF (M)
C36	or 2160520A23 2160520C21	8.2 ± 0.25pF (H) 680 (M)
C37	or 2160521C11 2160523F15	680 ±10% (H) 10
C39	2160521A24	8200
C40, 41	2160520C01	100
C42	2160520C13	330
C43	2111103A23	0.015µF±10%
C100	2160520A08	2 ± 0.25pF (2W), (M, 5W)
C101	or 2160520A05 2160520B08	1.5 ± 0.25pF (H, 5W) 20 (M)
C102	or 2160520B07 2160520B10	18 ± 0.25pF (H) 24 (M, 5W)
C107	or 2160520B09 or 2160520B12 2160520B19	22 (H) 30 (M, 2W) 56 (H, 5W)
C108	or 2160520B18 or 2160520B21	51 (M, 2W) 68 (M, 5W)
C109	or 2160520B19 2160520C13	56 (H, 2W) 33C
C110	2160520B14	36 (M, 2W)
C111	or 2160520B13 2160521G37	30 (M, 5W) 33 (H) 0.1µF + 10 - 20%
C112	2160520B17	47 (M, 2W)
C114	or 2160520B16 or 2160520B15 2160520B24	39 (M, 5W), (H, 2W) 39 (H, 5W) 91 (5W Models only) 330 (M), (H, 2W)
C115	2160521G37	0.1µF + 10 - 20% (M), (H, 2W)
C117	or 2160520C13 2160520B19	330 (H, 5W) 56 (M, 2W)
C118	or 2160520B23 or 2160520B17 or 2160520B22	82 (M, 5W) 47 (H, 2W) 75 (H, 5W)
C119	2160520B08	20 (M, 2W)
C120	or 2160520B03 2160520B05	12 (M, 5W) 13 (H, 5W)
C121	2160520B04	15 (H, 2W)
C122	or 2160520B09 2160520B09	22 (M, 2W) 22 (M, 2W)
C123	or 2160520B03 or 2160520B08	12 (M, 5W) 20 (H, 2W)
C130	or 2160520A23 2005588P01	8.2 (H, 5W) Trimmer, 5.5-55pF
C131	2160520B15	39 (M)
C132	or 2160520B14 2160520B07	36 (H) 18 (M, 2W)
C133	or 2160520B05 or 2160520B04	15 (M, 5W), (H, 5W) 13 (H, 2W)
C134	2160520B09	22 (M, 2W)
C140	or 2160520B08 or 2160520B07	20 (M, 5W) 18 (H)
C142	2160520C13	330 (M, 2W), (H)
C143	or 2160520A19 2160520C13	3300 (M, 5W) 330
C145	2160520A12	0.1µF + 80 - 20%
C146	or 2160520A13 2160520B10	4.3 ± 0.25pF (H, 5W Models only) 3 (M, 2W)
C147, 148	or 2160520B16 or 2160520B07	3.3 ± 0.25pF (5W), (H, 2W) 24 (M, 2W)
C149	or 2160520B06 or 2160520B01	43 (M, 5W) 18 (H, 2W) 27 (H, 5W)
C150	2160520B11	12 (M, 2W)
C151	or 2160520B03 or 2160520B07	18 (M, 5W) 16 (H, 5W)
C152	or 2160520B06 or 2160520B01	10 (H, 2W) 16 (M)
C153	2160520B06	13 (H)
C154	or 2160520B04 2160520C13	330 (2W Models) (H, 5W) 0.1µF + 80 - 20% (M, 5W)
C200 thru 202	2160520B07	330
C203, 205, 206	2160520B07	18 (M)
C204	or 2160520B04 or 2160520B05	13 (H, 2W) 15 (H, 5W)
C207	2160520C13	330
C209	2160521G37	0.015µF ± 10%
C210 thru 213	2160521A15	0.1µF + 80 - 20%
C301 thru 303	2160520C13	330
C304, 305	2160520B15	39 (M)
C306, 307	or 2160520B17 2160520B07	47 (H) 18 (M)
C309, 311	or 2160520B05 2160520C13	15 (H, 5W) 330
C310	2160520B11	330
CR1	2111032A23	Diode: See Note 1
CR2	2160521A15	Silicon
CR101	2160521G37	Silicon
CR102	2160520C13	18V, ZENER
CR301A, 301B	2305458G12	LED, Bicolor
E101	2160521A13	1000
E102	2160521A15	1500
F1	2160520B23	82
FL1, 2	2160520B23	56
FL3	2160520B19	82
FL4	2160520B23	82
L1	2160520B23	330
L2	2160520C13	Diode: See Note 1

L3, 4, 5	2405523P18	8-1/2 turns, closewound; with core
L6	2405063H13	Tunable, 1.2µH Choke
L7, 8	2405063H05	Tunable, 0.4µH Choke
L9	2405523P10	5-1/2 turns, spacewound (M)
L10	or 2405523P09 2405523P08	4-1/2 turns, spacewound (H) 4-1/2 turns, spacewound (M)
L11	2482723H38	3-1/2 turns, spacewound (H)
L12	2505129Q02	1.2µH Choke
L101	2482723H28	1.2µH Choke, precision
L102	2405523P28	0.29µH Choke
L103	2482723H38	6-1/2 turns, spacewound
L104	2405523P32	1.2µH Choke
L105	2405523P07	9-1/2 turns, closewound
L106	2405913C01	2-1/2 turns, spacewound
L107	2482723H28	3-turn ferrite bead
L108	or 2482723H13 2405523P07	0.29µH Choke (2W Models) 0.85µH Choke (5W Models) 2-1/2 turns, spacewound (2W)
L109	2405559P09	1-1/2 turns, airwound (5W Models)
L110	2405913C01	3-turn ferrite bead
L111	2482723H13	.085µH Choke
L112	2405559P07	2-1/2 turns, airwound
L113, 114	2405559P11	4-1/2 turns, airwound (M)
L115	2405559P01	6-1/2 turns, airwound (M) (H, 2W)
L116, 117	or 2405559P02 2482723H38	5-1/2 turns, airwound (H, 5W) 6-1/2 turns, airwound (M)
L119, 120	2405559P01	5-1/2 turns, airwound (H)
L201	2405452C70	1.2µH Choke
LS1	5005155Q03	6-1/2 turns, airwound (H)
MK1	0105956P37	190µH Choke
P1	-----	TRANSUCER MICROPHONE ASSEMBLY: PLUG: Not field replaceable, order Freq. Switch Flex Assembly 0105956M68
P2	-----	Not field replaceable, order Volume Pot Flex Assembly 0105956M66
P3, 4	-----	Not field replaceable, order Synthesizer U202
P5	-----	Not field replaceable, order Microphone Assembly 0105956M62
P6	-----	Not field replaceable, order I-F module U1
P7	-----	Not field replaceable, order Top Control Panel Assembly 0105951N41
Q1	4805218N08	TRANSISTOR: See Note II NPN
Q2	4805452G08	Dual Gate MOSFET; Type M52G08
Q3	4805218N09	NPN
Q101, 102	4805218N09	NPN
Q103	4805474G37	NPN; Type M74G37
Q104	4805452G06	NPN; Type M52G06 (2W Models)
R1	0660076A67	NPN; Type M74G33 (5W Models)
R2	0660076A67	RESISTOR, Fixed: W ± 5%; 1/10W unless stated
R3	0660076A59	5.6k
R6	0660076A49	38k
R7	0660076A73	2.7k
R9	0660076A45	1k
R10	0660076A56	10k
R13	0660076A71	680
R14	0660076A84	2k
R15	0660076A71	8.2k
R16	0660076A43	30k
R17	0660076A25	8.2k
R100	0660076A71	560
R101	0660076A84	100
R102	0660076A65	8.2k
R103	0660076A68	30k
R104	or 0660076A69 0660076A84	4.7k 6.2k (2W Models) 6.8k (5W Models) 30k (M, 2W) 24k (5W Models) 18k (H, 2W) 100 (M, 2W) 110 (5W Models)
R105	0660076A25	
	or 0660076A26	

R106	or 0660076A32 0660076A67	200 (H, 2W) 5.6k (M, 2W), (H)
R108	or 0660076A73 0660076A17	10k (M, 5W) 47 (2W)
R109	or 0660076A23 0660076A17	82 (5W) 47 (M, 2W), (H)
R111	or 0660076A09 0660076A46	22 (M, 5W) 750
R112	0660076A29	150 (5W Models) Not used on 2W Models
R127	0660076A29	150
R128	0660076A71	8.2k
R129	1805581P01	Pot., 50k
R130	0660076A87	39k
R131	0660076A25	100 (H, 2W Models only)
R140	1805100Q03	Pot., 5k
S1	-----	SWITCH: On/Off, Part of R140
S2	4005265Q01	2- & 8-channel radios
S3	or 4005265Q02 4005101Q01	16-channel radios Toggle, SPDT
S301	3905834K01	Snap Dome, Monitor
S302	3905834K01	Snap Dome, PTT
S303	3905834K01	Snap Dome, Monitor
U1	5105849S01	CIRCUIT MODULE: See Note I I-F
U103	5105822P51	I-F (12.5kHz channel spacing only)
U104	5105822P64	Antenna Switch
U106	or 5105729E93 5105729E52 5105729E72	Antenna Selector (2W) Antenna Selector (5W) Ref. Oscillator Ref. Oscillator (12.5kHz channel spacing only)
U201	5105822P60	VCO (M)
U202	or 5105822P59 5105822P76	VCO (H) Synthesizer
VR102	4805129M61	DIODE: See Note I Zener, 18V
VR301	4805129M42	Zener, 5.6V

NONREFERENCED ITEMS	
0200007007	NUT, Hex; 8-32 X 1/4" X 3/32"
0300136771	(for Q104, 5W Models) SCREW, Phillips; 2-56 X 3/16" (for Q104 heatsink) BOOT, for FL1, FL2 SUPPORT, Rubber INSULATOR, for Q103 INSULATOR, for U106 INSULATOR (I-F) SHIELD, I-F Module CAN, for L11, L12 CAN, for L111 thru L115, L119, L120, and L108 (5W Models) HEAT SINK, for Q104 (5W Models) HEAT SINK, for Q104 (2W Models) CAN, for L1, L2 HEAT SINK, for Q103 CONTACT STRIP CONTACT PAD, for FL1, FL2 CUSHION, for U106 PC BOARD (2W) PC BOARD (5W)
0705196A04	
0705766R01	
1400861196	
1405238Q01	
1405496B01	
2605116S01	
2605494B01	
2605524P01	
2605524P03	
2605532P01	
2605578P01	
2605820D07	
2683379H01	
3905130N01	
3905509R02	
7505295B07	
7505695R01	
8405589P02	
8405591P02	

NOTES:

- For optimum performance, order replacement diodes, transistors, and circuit modules by Motorola part number only.
- When ordering crystal units, specify carrier frequency, crystal frequency, crystal type number, and Motorola part number.

* Not field replaceable, order microphone flex assembly 0105956P37.

MICROPHONE FLEX ASSEMBLY MK1

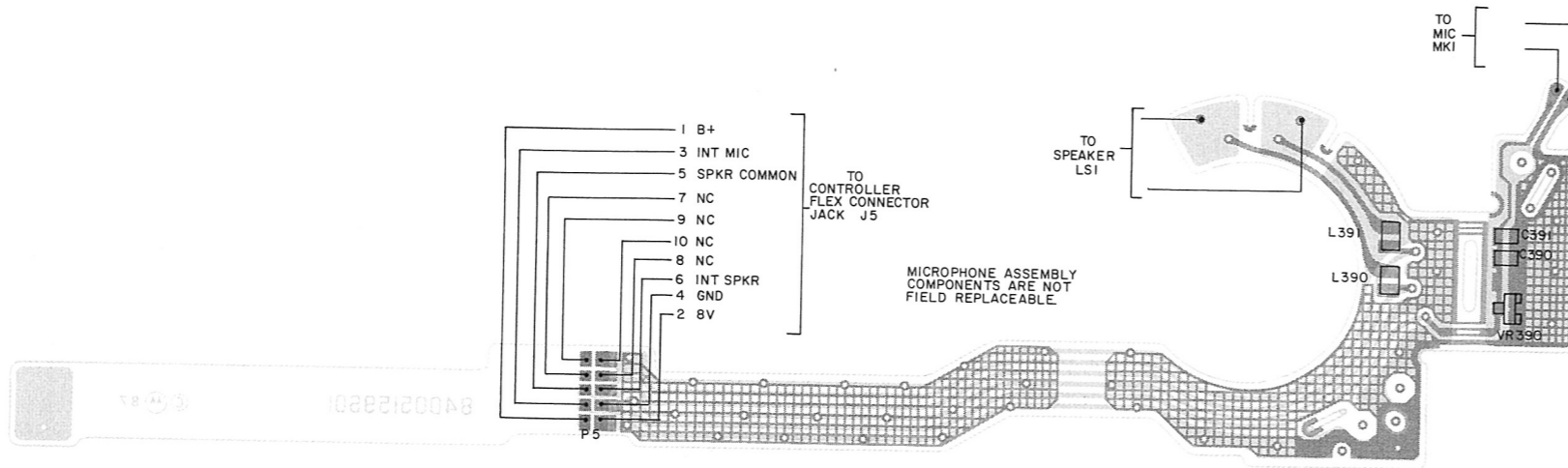

L1-BEPF-18173-0
L2-BEPF-18174-0
OL-BEPF-18175-0

VOLUME POT FLEX

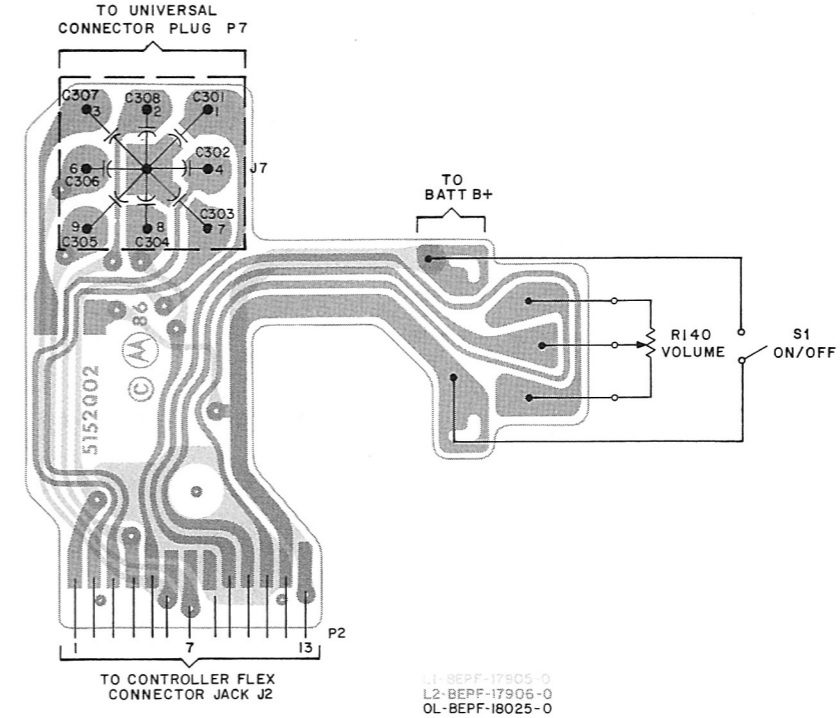

L1-BEPF-17905-0
L2-BEPF-17906-0
OL-BEPF-18025-0

FREQUENCY SWITCH FLEX

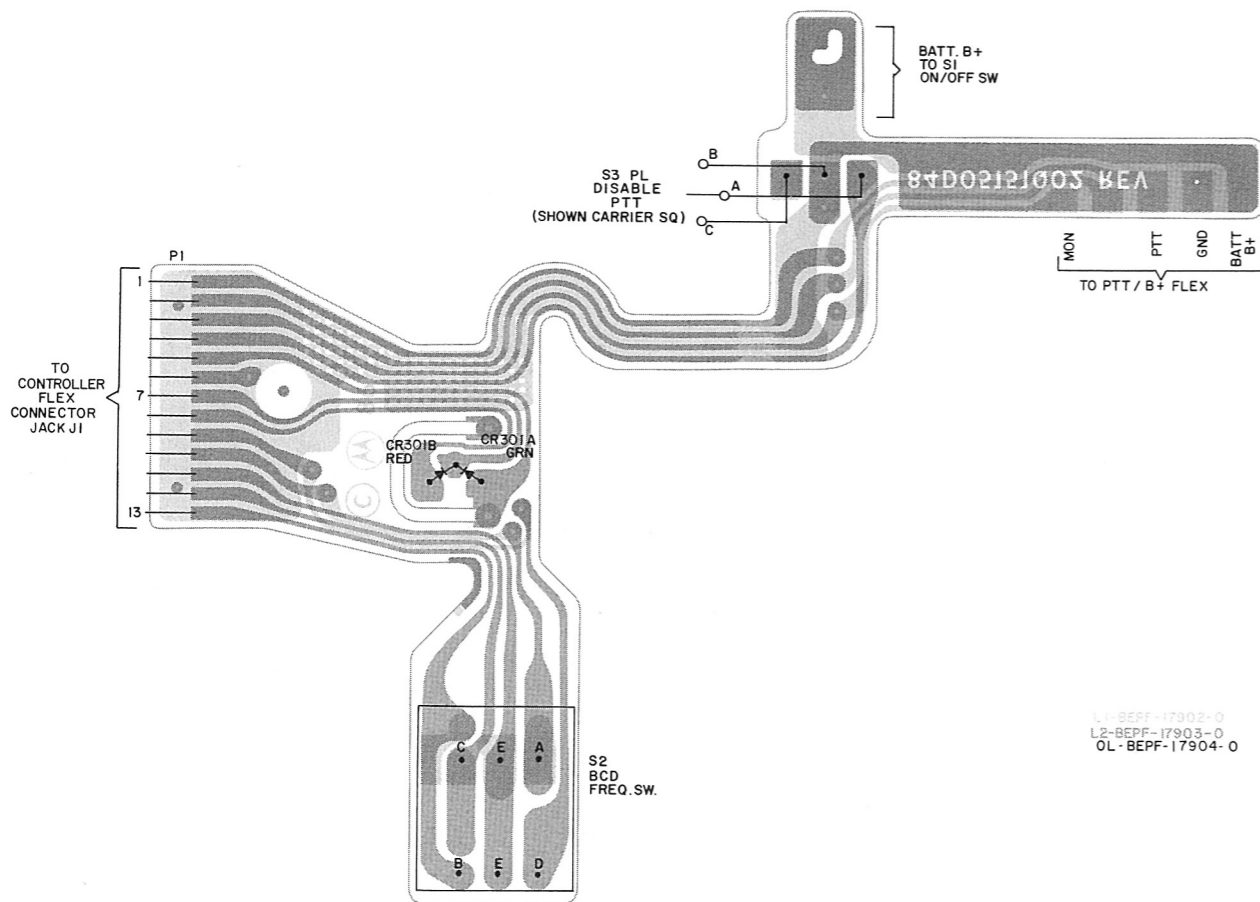

L1-BEPF-17903-0
L2-BEPF-17903-0
OL-BEPF-17904-0

PTT/B+ FLEX

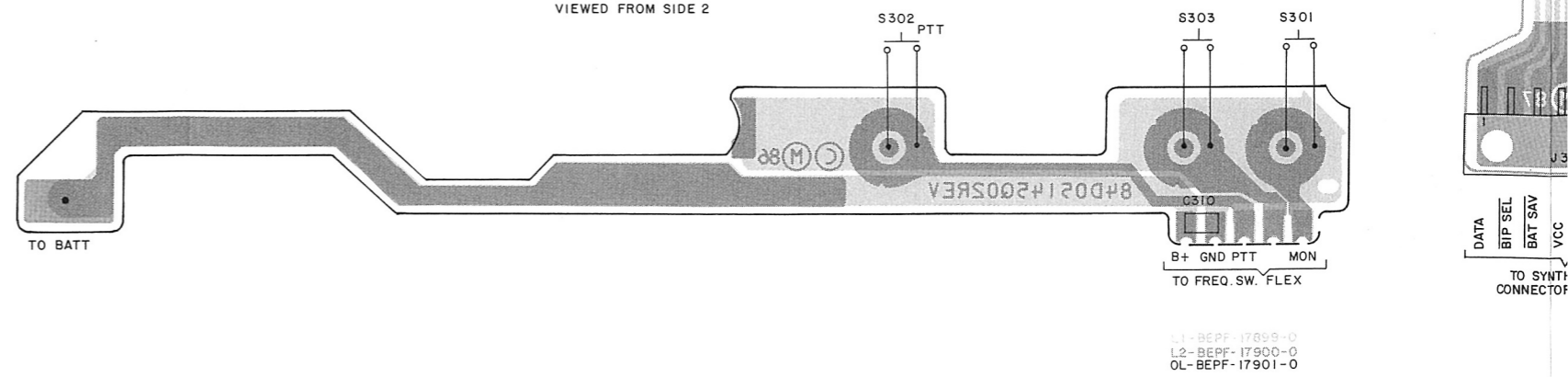

L1-BEPF-17899-0
L2-BEPF-17900-0
OL-BEPF-17901-0

TO FREQUENCY SWITCH
CONNECTOR PLUG
PTT
RAT
MON
PL SW
LED RX
GND
LED TX
BCD D

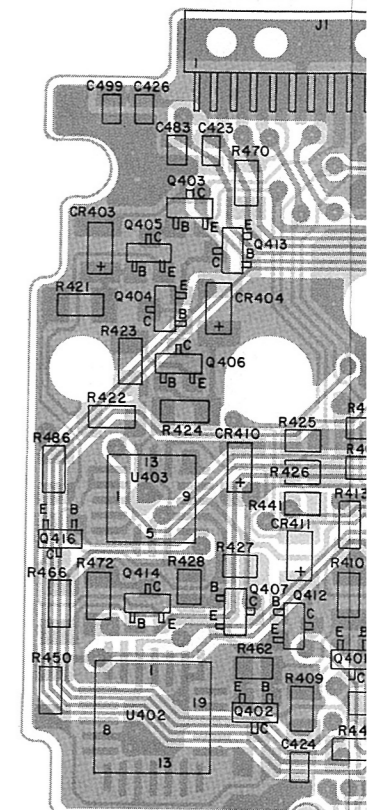

DATA
BIP SEL
BAT SAV
VCC
TO SYNTH
CONNECTOR

VOLUME POT FLEX

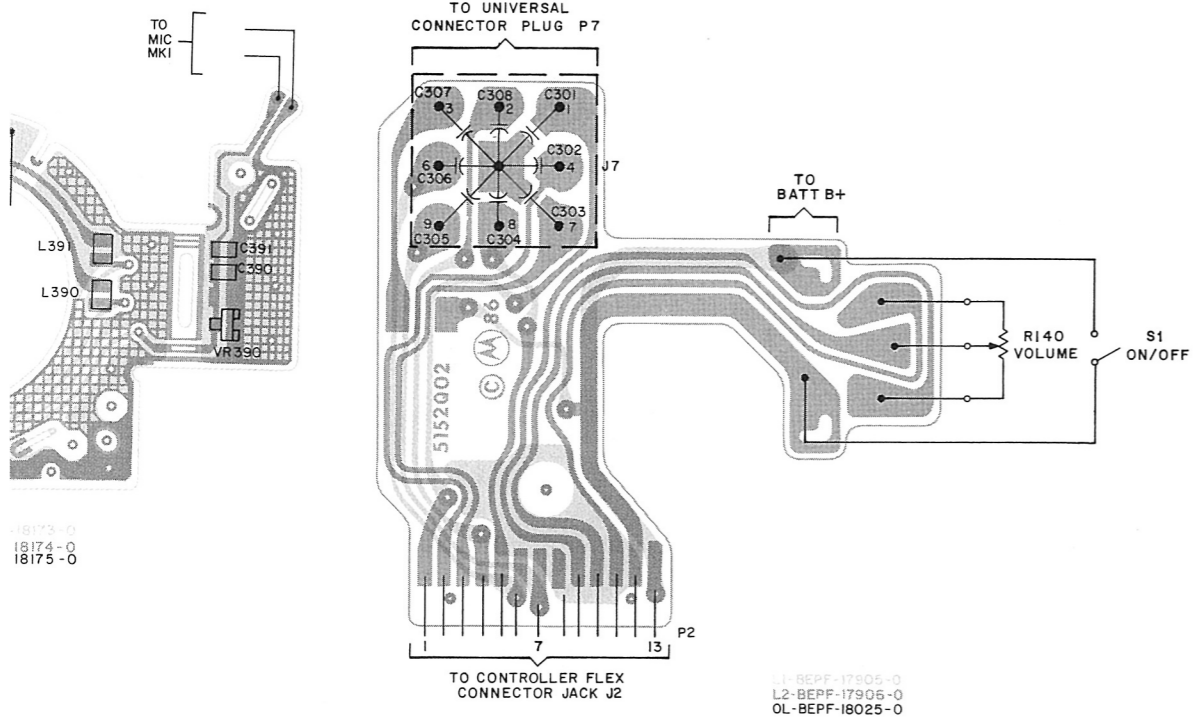

CONTROLLER FLEX

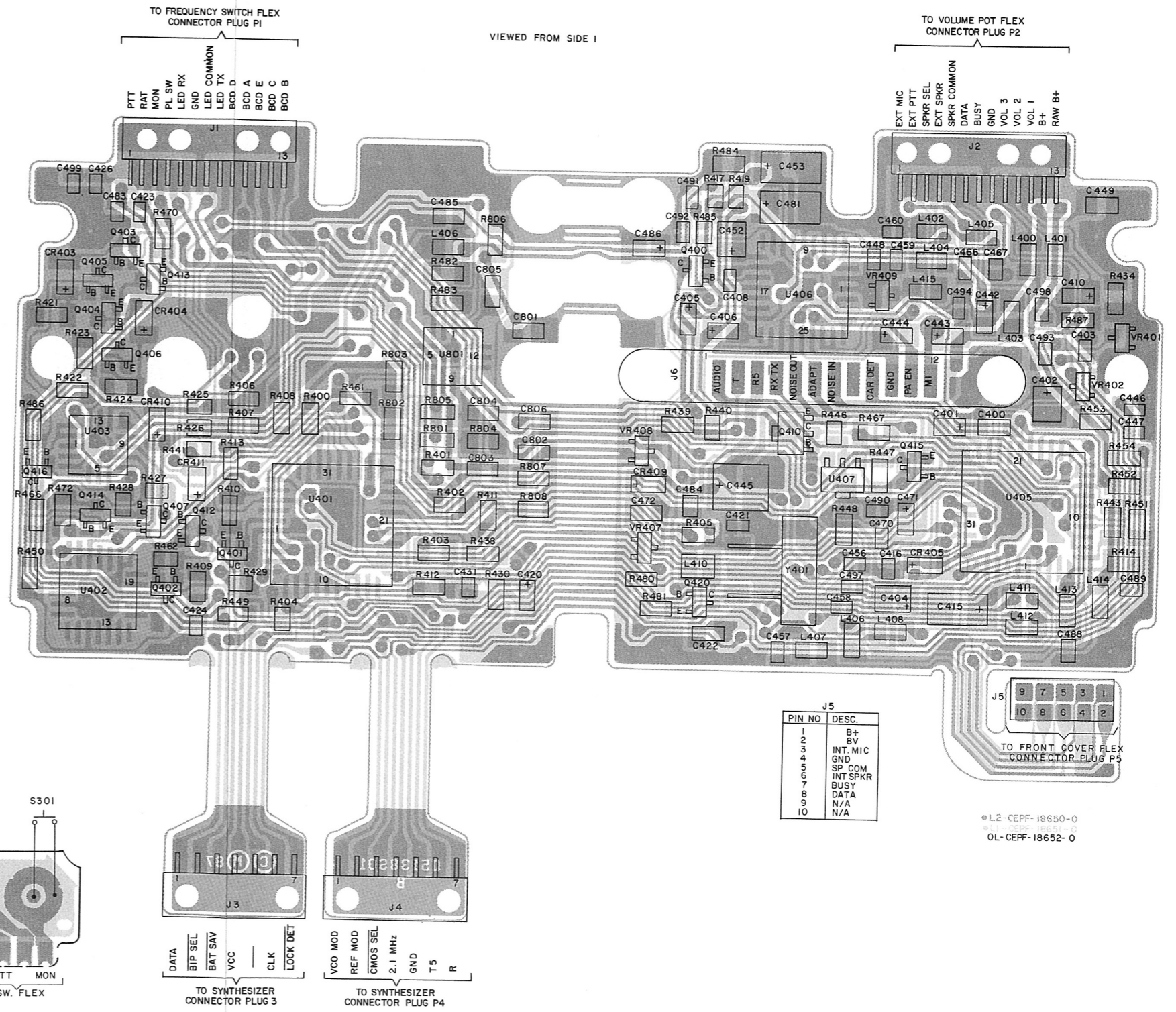

PTT/B+ FLEX

VIEWED FROM SIDE 2

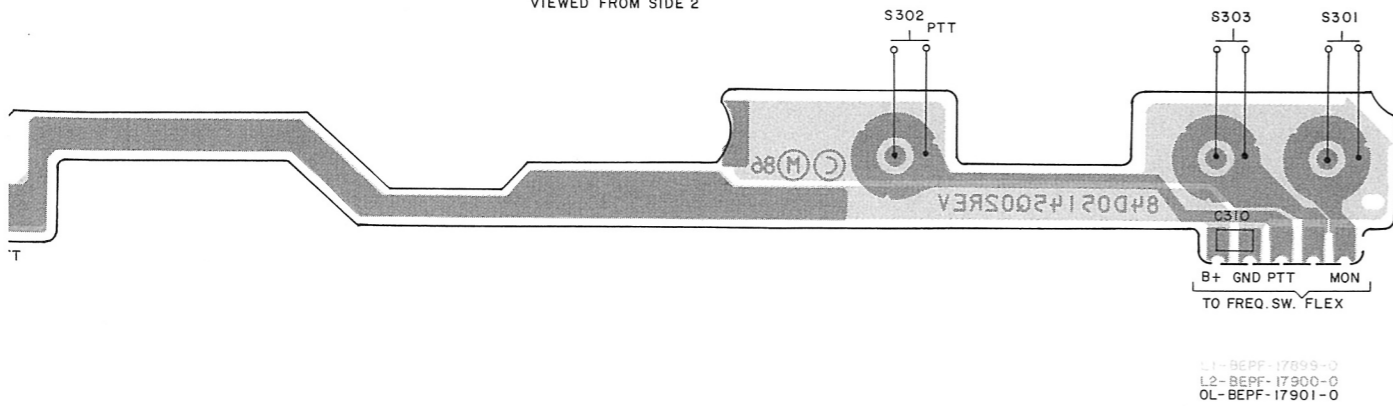

J5	
PIN NO	DESC.
1	B+
2	SV
3	INT. MIC
4	GND
5	SP COM
6	INT SPKR
7	BUSY
8	DATA
9	N/A
10	N/A

Exploded View Parts List

TPLF-3556-0

ITEM NO.	MOTOROLA PART NO.	DESCRIPTION
1	0105956M63	ASSEMBLY, Frame
2	NHN6419A	KIT, Housing; includes items 36 thru 51
3	NTN4956A	KIT, Front Cover; includes items 4, 45, 79 thru 86
4	3305260Q06	NAMEPLATE, Front
5	-----	Not Used
6	0300136785	SCREW, Phillips; 4-40 x 3/16"
7	NTN5374A	KIT, Controller Flex; includes items 8, 9, 10, 13, 14, 67, 68, 69, 75, 77, 78
8	0105952P34	SHIELD, Bottom
9	-----	ASSEMBLY, Controller Flex; part of item 7
10	-----	SHIELD, Center; Top Carrier Side; part of item 7
11	1505102S01	COVER, Dust
12	0105951N79	ASSEMBLY, Knob; VOLUME
13	1505182S01	CARRIER, Top; Controller Flex
14	-----	SHIELD, Center; Bottom Carrier Side; part of item 7
15	0300136771	SCREW, Phillips; 2-56 x 3/16" (4 req'd.)
16	1305676R01	ESCUTCHEON, 2-channel
	or 1305676R03	ESCUTCHEON, 8-channel
	or 1305676R06	ESCUTCHEON, 16-channel
17	0205629L01	NUT, Hex (2 req'd)
18	0405534R01	WASHER, Flat; Octagonal
19	0205163Q01	NUT, Spanner
20	0405162Q02	WASHER, Flat; Volume Pot and Freq. Switch
21	0405216L04	WASHER, Flat
22	0205765L02	NUT, Spanner
23	See Note	LED, Bicolor (CR301A, 301B)
24	3205157Q01	SEAL, LED
25	0105951N41	ASSEMBLY, Control Top
26	-----	Not Used
27	See Note	SWITCH, Frequency (S2)
28	0405162Q01	WASHER, Flat
29	3205082E01	GASKET, O-Ring; (2 req'd.)
30	0484345A06	WASHER, Seal
31	See Note	SWITCH / POT, On-Off / Volume (S1 / R140)
32	3205141Q02	GASKET, O-Ring
33	3205141Q03	GASKET, O-Ring; Mode Select Switch
34	0405218Q01	WASHER, Flat; Octagonal (2- & 8-channel)
	or 0405534R01	WASHER, Flat; Octagonal (16-channel)
35	0300140369	SCREW, Flat Hd.; 2-56 x 1/8" (4 req'd)
36	4605945K05	CONTACT STUD, Battery
37	3905127Q01	CONTACT, B+
38	3205082E24	GASKET, O-Ring
39	0705830C02	SUPPORT, Contact (2 req'd)
40	3905421C07	CONTACT, Battery (2 req'd)
41	2905124Q01	LUG (2 req'd)
42	0400002625	LOCKWASHER, Split #2 (3 req'd)
43	4105944K01	SPRING, Battery Latch (2 req'd)
44	5505536P01	LATCH
45	0300139982	SCREW, Phillips Hd.; 2-56 x 5/32" (7 req'd)
46	3205082E03	GASKET, O-Ring (2 req'd)
47	See Note	FUSE (F1)
48	0400009761	LOCKWASHER, Split #4 (2 req'd)
49	0305941K01	SCREW, Captive; 4-40 (2 req'd)
50	6405531P02	PLATE, Base
51	4505535P01	LEVER, PTT
52	0305137Q01	SCREW, Phillips Hd.; 4-40 x 1/2" (2 req'd)
53	0484345A06	WASHER, Seal (2 req'd)
54	-----	LABEL, FCC
55	-----	LABEL, FM
56	3205231Q01	SEAL, Dome (PTT); part of item 59
57	3205196Q01	SEAL, Dome (Mon); part of item 59
58	3905834K04	CONTACT, Snap Dome; part of item 59
59	0105951N40	ASSEMBLY, B+ / PTT Flex; includes items 56, 57, 58 (P/O U201)
60	See Note	PLUG (P3)
61	See Note	PLUG (P4)
62	See Note	FLEX, Connector (P/O of U1)
63	See Note	ASSEMBLY, Main Back Shield
64	0105953N75	SCREW, Phillips Hd.; 2-56 x 5/16" (5 req'd)
65	0300136772	HEATSINK (5W radios)
66A	2605532P01	HEATSINK (1W and 2W radios)
66B	2605578P01	HEATSINK (1W and 2W radios)
67	0300138620	SCREW, Phillips; 2-56 x 5/16" (2 req'd)
68	See Note	JACK (J2)

69	See Note	JACK (J1)
70	0102700J17	ASSEMBLY, Front Shield
71	1405264Q01	INSULATOR, Flex
72	See Note	PLUG (P2)
73	See Note	PLUG (P1)
74	0105956M66	ASSEMBLY, Volume Pot Flex
75	See Note	JACK (J3)
76	0105956M68	ASSEMBLY, Frequency Flex
77	See Note	JACK (J4)
78	See Note	JACK (J5)
79	3205141Q01	GASKET, O-Ring
80	4205140Q01	CLAMP, Speaker (3 req'd)
81	See Note	SPEAKER (LS1)
82	4205136S01	RETAINER, Microphone
83	1405299L01	BOOT, Microphone; part of item 98
84	See Note	ASSEMBLY, Microphone Flex (MK1); includes item 90
85	7505564S01	PAD, Microphone Boot
86	7505501R03	PAD, Front Cover
87	0300140041	SCREW, Phillips; 2-56 x 1/4" (2 req'd)
88	0105958N94	ASSEMBLY, Speaker Felt
89	See Note	PLUG (P5)
90	-----	CARTRIDGE, Microphone; part of item 84
91	See Note	SWITCH (S3)
92	1405299Q01	INSULATOR, Speaker
93	7505501R02	PAD, Speaker
94	0105950N92	ASSEMBLY, Knob
95	2605494R01	SHIELD, I-F
96	2605123S01	SHIELD, PC BOARD; Bottom
97	0200007007	NUT, Hex (for Q104 5W radios only)
98	0305103S01	SCREW, Captive
99	3905178S01	CONTACT
100	1405496R01	INSULATOR
101	0300139685	SCREW, Phillips; 2-56 x 5/32"
102	0484345A06	WASHER, Seal

NOTE: Refer to Electrical Parts List for part number and description.

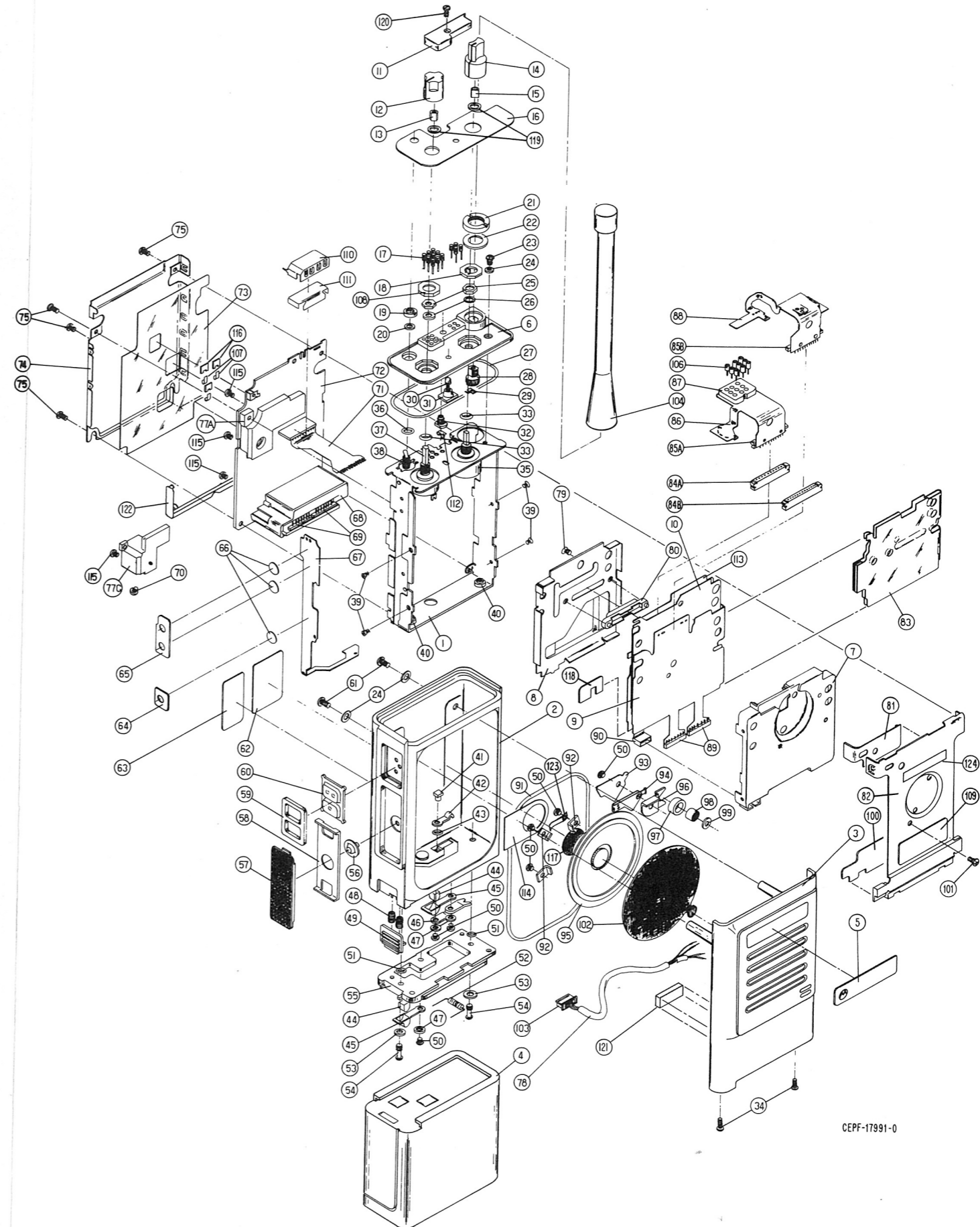

CEPF-17991-0

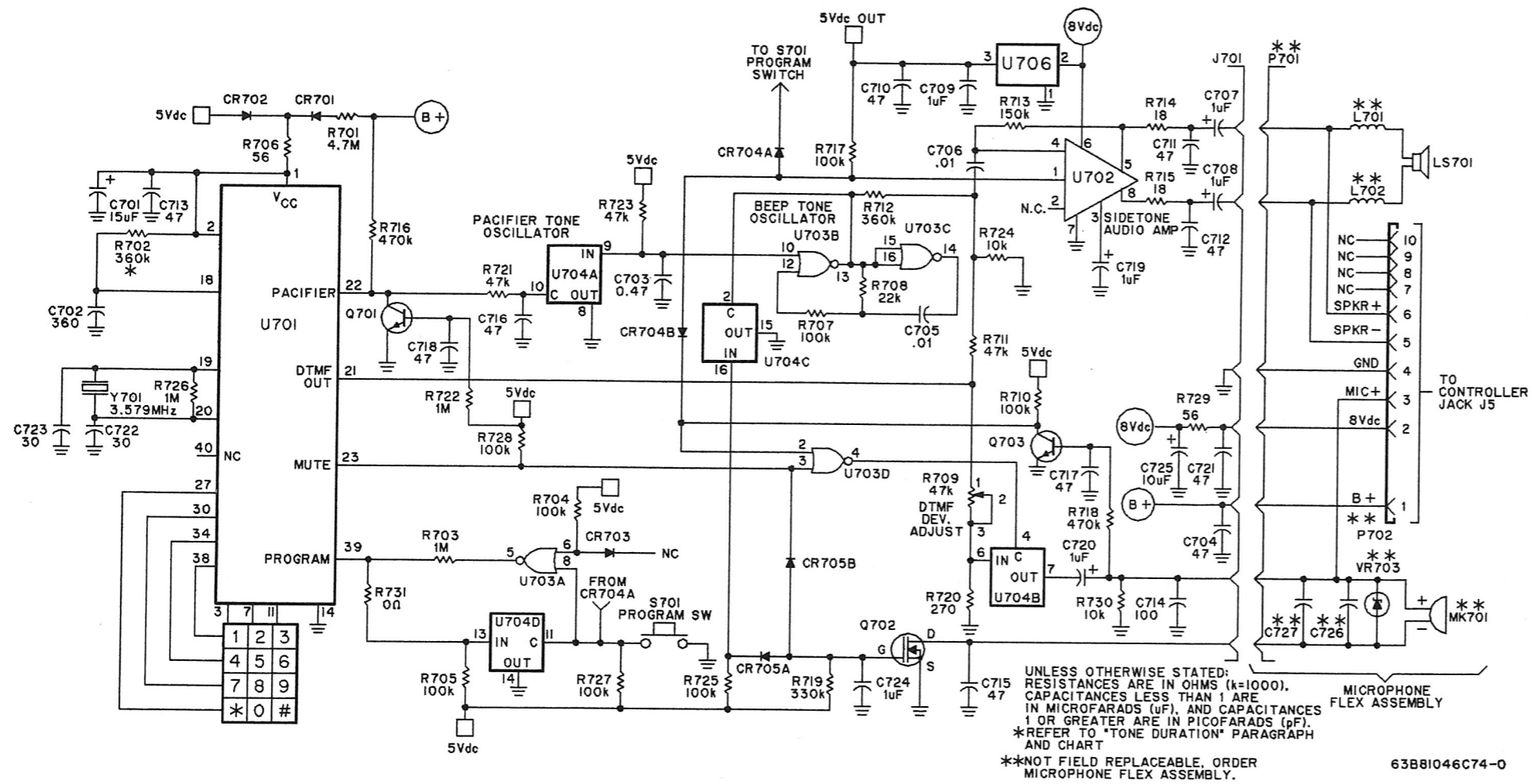

VIEWED FROM SIDE 1

MICROPHONE FLEX ASSEMBLY MK701

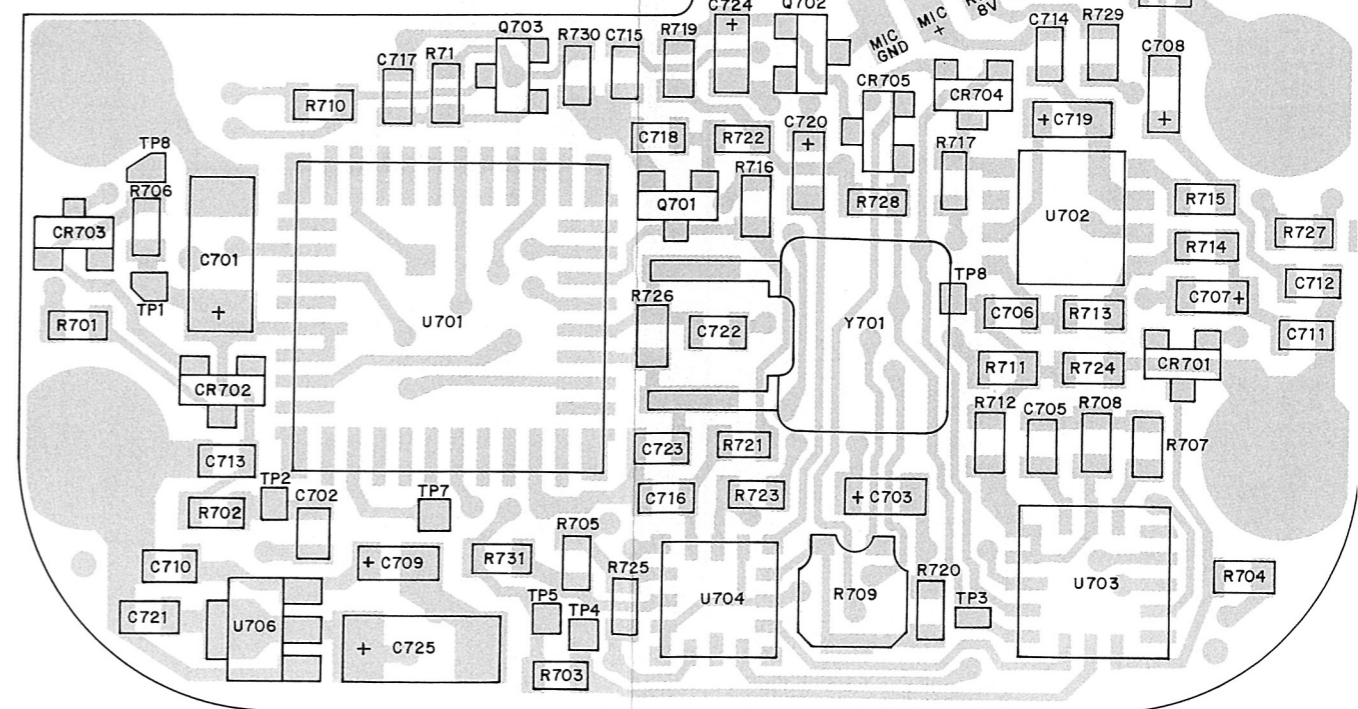
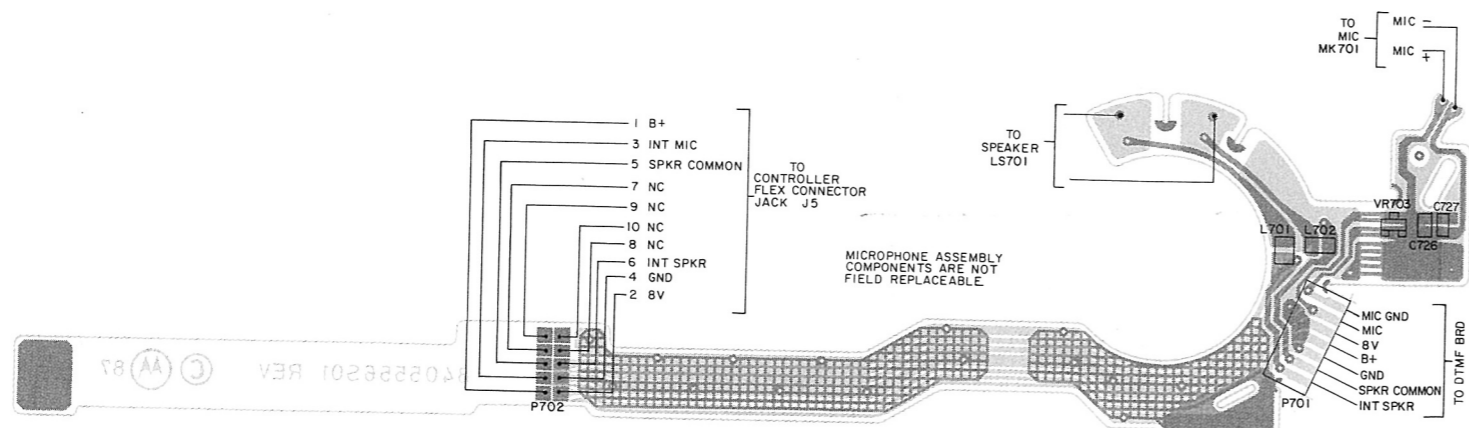

L1-BEPF-18767-0
L2-BEPF-18568-0
OL-BEPF-18766-0

L1-CEPF-18767-0
OL-CEPF-18791-0

NTN4884B DTMF Front Cover
Electrical Parts List

TPLF-3646-O

REFERENCE SYMBOL	MOTOROLA PART NO.	DESCRIPTION	
C701	2362998C24	CAPACITOR, Fixed: uF±10%; 16V unless stated 15;10V; Tant. 360pF±2%;25V 0.47;35V 47pF±5%;50V .01;25V 1 47pF±5%;50V 100pF±5% 47pF±5%;50V 1 47pF±5%;50V 30pF±5%;50V 1 10±20%	
C702	2160520C14		
C703	2362998C05		
C704	2160520B17		
C705, 706	2160521C25		
C707 thru 709	2362998C09		
C710 thru 713	2160520B17		
C714	2160520C01		
C715 thru 718	2160520B17		
C719, 720	2362998C09		
C721	2160520B17		
C722, 723	2160520B12		
C724	2362998C09		
C725	2362998B73		
C726 **	-----		
C727 **	-----		
CR701 thru 705	4805129M24		DIODE: See Note I Switching
L701, 702 **	-----		COIL: 0.39uH Choke
LS701	5005155Q03		TRANSDUCER
MK701 **	-----		MICROPHONE
P701 **	-----	PLUG: Contacts, flex circuit plating Socket, 10-Pin	
P702 **	-----		
Q701	4805128M11	TRANSISTOR: See Note I SOT D-MOS SOT	
Q702	4805218N11		
Q703	4805128M11		
R701	0660076H41	RESISTOR, Fixed: Ω ±5%;1/10W unless stated 4.7Meg 360k 1Meg 100k 56;1/8W 100k 22k Pot., 47k 100k 47k 360k 150k 18 470k 100k 470k 330k 270 47k 1Meg 47k 10k 100k 1Meg 100k 10k 0	
R702	0660076B14		
R703	0660076B25		
R704, 705	0660076B01		
R706	0660076A19		
R707	0660076B01		
R708	0660076A81		
R709	1860502A17		
R710	0660076B01		
R711	0660076A89		
R712	0660076B14		
R713	0660076B05		
R714, 715	0660076A07		
R716	0660076B17		
R717	0660076B01		
R718	0660076B17		
R719	0660076B13		
R720	0660076A35		
R721	0660076A89		
R722	0660076B25		
R723	0660076A89		
R724	0660076A73		
R725	0660076B01		
R726	0660076B25		
R727, 728	0660076B01		
R729 **	-----		
R730	0660076A73		
R731	0660076M01		
S701	-----	SWITCH: Program, Single-Pole (Not replaceable, order DTMF Front Cover Kit)	
S702	-----	Keypad (Not replaceable, order DTMF Front Cover Kit)	
U701	0105953P31	CIRCUIT MODULE: See Note I Tone Generator Audio Amplifier	
U702	5105469E51		

U703	0105953P32	Quad NOR Gate
U704	0105953P33	Analog Switch
U706	5160880B01	5-Volt Regulator
VR703 **	-----	DIODE: See Note I Zener, 5.6V
Y701	4805719G04	CRYSTAL: See Note II 3.579 MHz Resonator

NOTES:

I. For optimum performance, order replacement diodes, transistors, and circuit modules by Motorola part number only.

II. When ordering crystal units, specify carrier frequency, crystal frequency, crystal type number, and Motorola part number.

** Not field replaceable, order microphone flex assembly 0105956P38.

TONE DURATION

DTMF radios transmit timed DTMF tones. These tones are preset at the factory for 150ms. duration. To accommodate equipment with timing requirements other than 150ms., the tone duration can be changed by changing resistor R702, which is located between pins 2 and 18 of U701 (lower left corner of circuit board). Refer to the following table for details.

R702

MOTOROLA PART NUMBER	VALUE OHMS ±5%	TONE DURATION RANGE (ms)	TONE DURATION NOMINAL Tn (ms)
0660076B10	240k	94 - 108	101
0660076B12	300k	117 - 135	126
0660076B14	360k	141 - 162	150
0660076B16	430k	168 - 193	180
0660076B17	470k	184 - 211	197
0660076B18	510k	199 - 229	214
0660076B19	560k	219 - 252	235
0660076B20	620k	242 - 279	260
0660076B21	680k	266 - 306	285
0660076B22	750k	293 - 337	315
0660076B23	820k	320 - 368	344
0660076B24	910k	355 - 409	382
0660076B25	1M	391 - 449	420

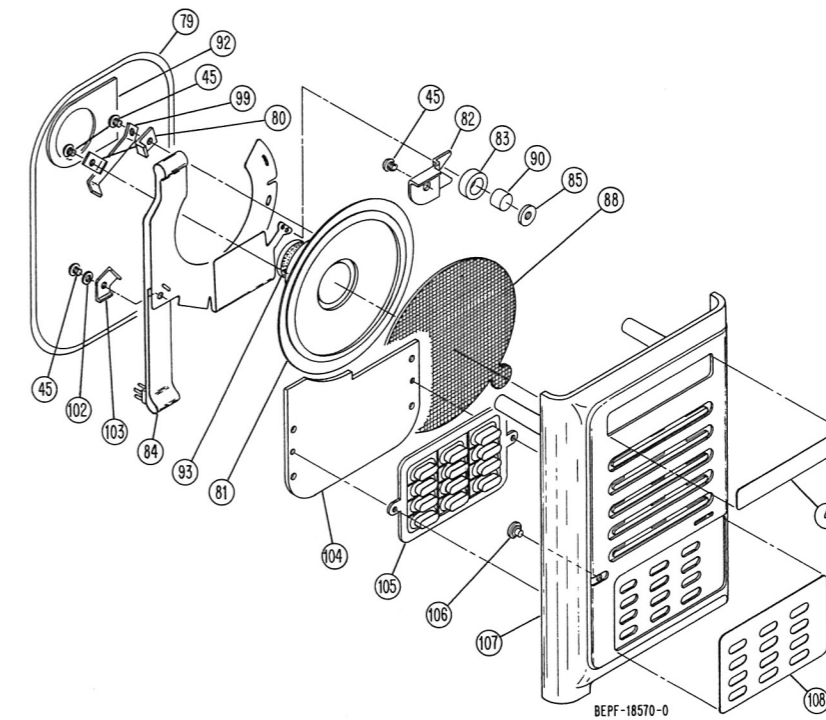

NTN4884A DTMF Front Cover
Exploded View Parts List

TPLF-3589-O

ITEM NO.	MOTOROLA PART NO.	DESCRIPTION
84	0105956P38	ASSEMBLY, DTMF Microphone Flex
102	0484345A06	WASHER, Seal
103	0705456R01	BRACKET, Speaker
104	-----	* CIRCUIT BOARD, DTMF
105	-----	* SWITCH, Keypad
106	-----	* SWITCH, Actuator
107	-----	* COVER, Front
108	1305455R01	ESCUTCHEON, DTMF

Note: Motorola part number and description of DTMF Exploded View items (ITEM NO.s 4 to 83, 85, 88, 90, 93, and 99) correspond to those of the standard radio Exploded View and Exploded View Parts List. The following items are unique to DTMF Front Cover.

* Not field replaceable, order DTMF Front Cover Kit NTN4884A.

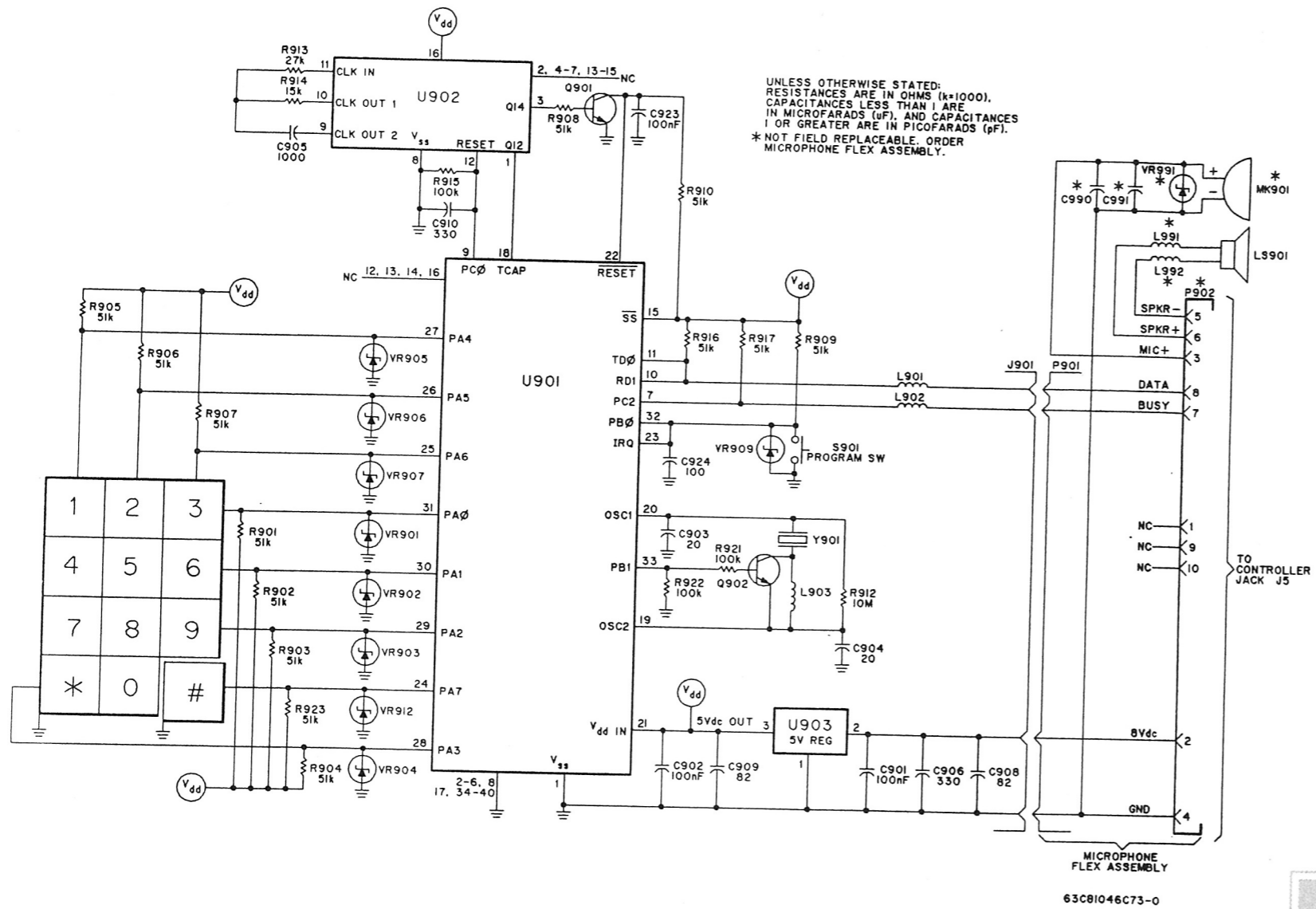

MICROPHONE FLEX ASSEMBLY MK901

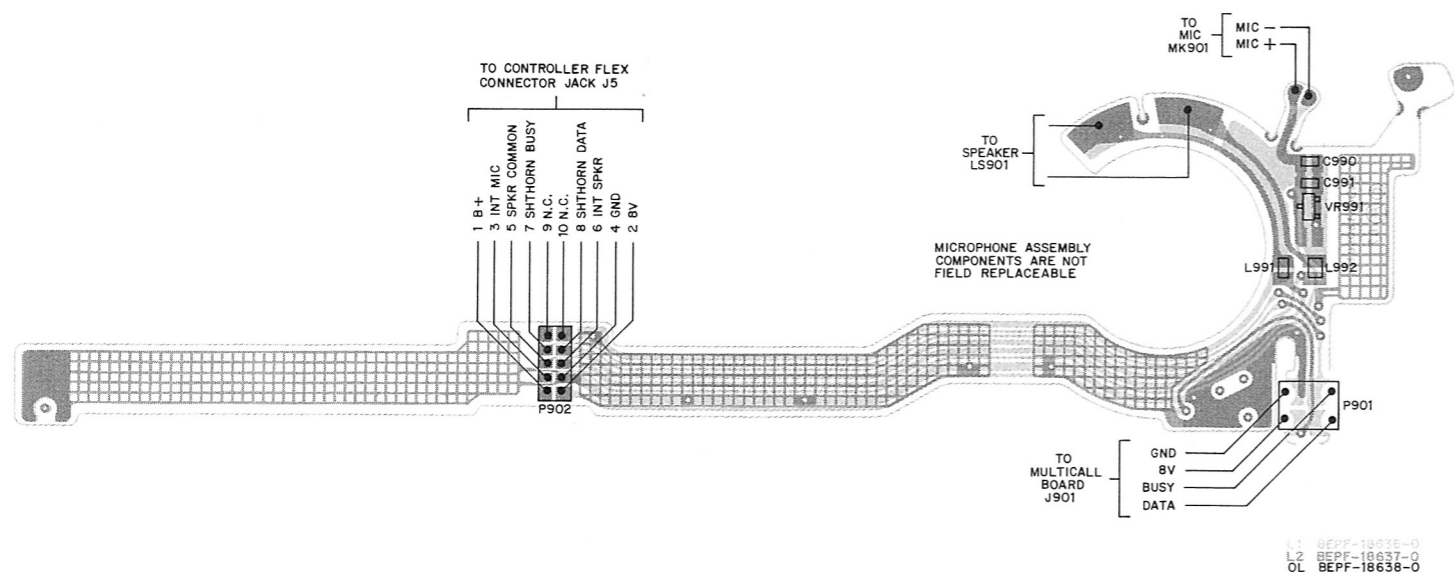

L1 BEPF-18634-0
L2 BEPF-18637-0
OL BEPF-18638-0

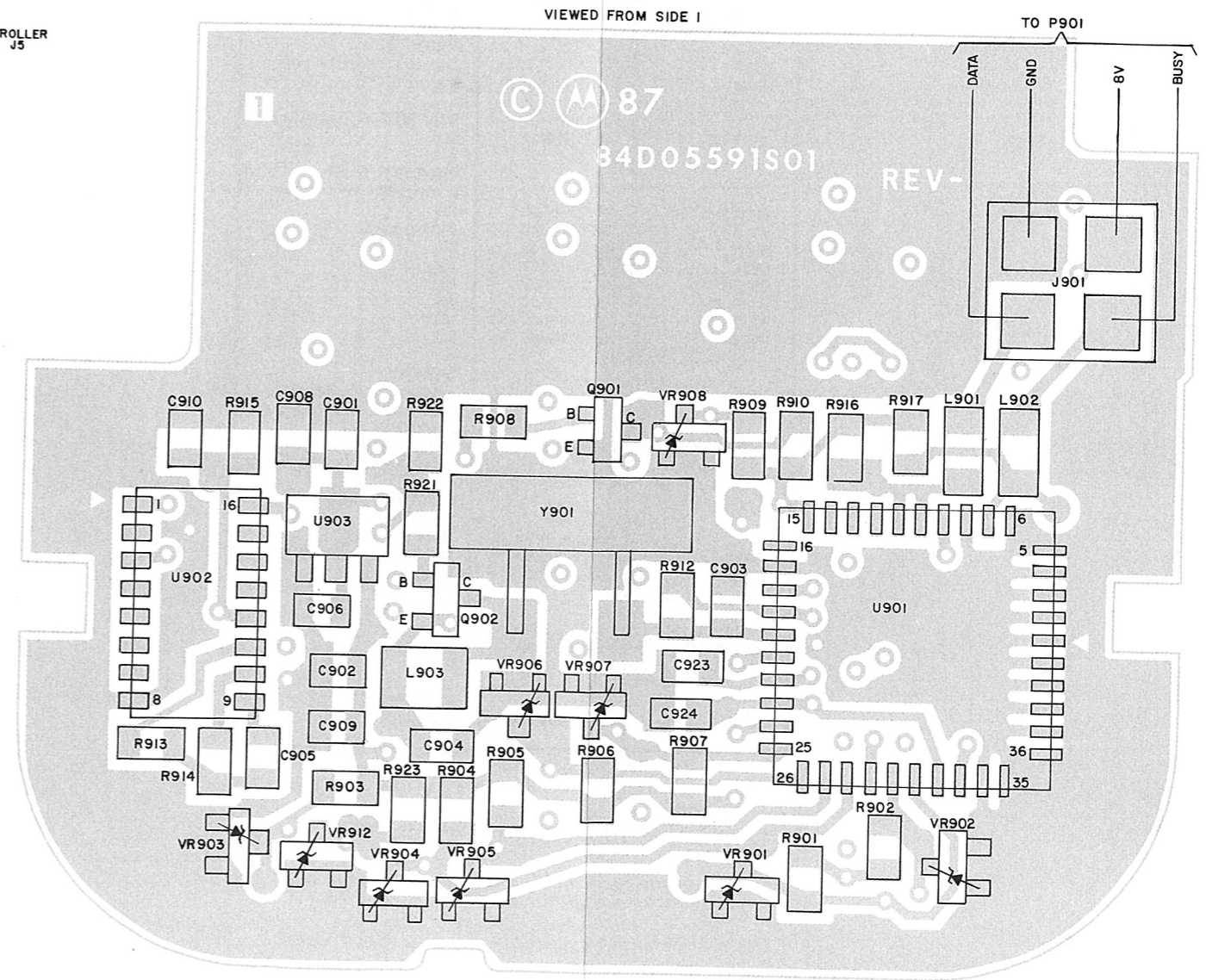

MULTICALL CIRCUIT BOARD, FLEX ASSEMBLY, AND SCHEMATIC DIAGRAM

L1-CEPF-18634-0
OL-CEPF-18635-0

**NTN4958A Multicall Front Cover
Electrical Parts List**

TPLF- 3600 - O

REFERENCE SYMBOL	MOTOROLA PART NO.	DESCRIPTION
C901, 902 C903, 904 C905 C906 C908, 909 C910 C923 C924 C991 * C992 *	2160521G37 2160520B08 2160521A13 2160520C13 2160520B23 2160520C13 2160521G37 2160521A13 ----- -----	CAPACITOR, Fixed: pF±5%; 16V unless stated 100nF; +80-20% 20 1000 330 82 330 100nF; +80-20% 1000
L901, 902 L903 L991, 992 *	2462575A03 2460590A03 -----	COIL: 0.82uH Choke 180 uH Chip Inductor
LS901	5005155Q03	TRANSDUCER
MK901 *	-----	MICROPHONE
P901 * P902 *	----- -----	PLUG: Contacts, flex circuit plating Socket, 10-Pin
Q901, 902	4805128M12	TRANSISTOR: See Note I SOT
R901 thru 910 R912 R913 R914 R915 R916, 917 R921, 922 R923	0660076A90 0660076H49 0660076A83 0660076A77 0660076B01 0660076A90 0660076B01 0660076A90	RESISTOR, Fixed: Ω ±5%; 1/8W unless stated 51k 10 Meg ±10% 27k 15k 100k 51k 100k 51k
S901	-----	SWITCH: Program, Single-Pole (Not replaceable, order Multicall Front Cover Kit)
S902	-----	Keypad (Not replaceable, order Multicall Front Cover Kit)
U901 U902 U903	0105805P23 5105469E52 5160880B01	CIRCUIT MODULE: See Note I Microcomputer 14-bit Frequency Counter 5-Volt Regulator
VR901 thru 908 VR912 VR991 *	4880140L09 4880140L09 -----	DIODE: See Note I Zener, 6.2V Zener, 6.2V
Y901	4805664G33	CRYSTAL: See Note II 3.6864 MHz Resonator

NOTES:

- I. For optimum performance, order replacement diodes, transistors, and circuit modules by Motorola part number only.
- II. When ordering crystal units, specify carrier frequency, crystal frequency, crystal type number, and Motorola part number.

* Not field replaceable, order microphone flex assembly 0105956P58.

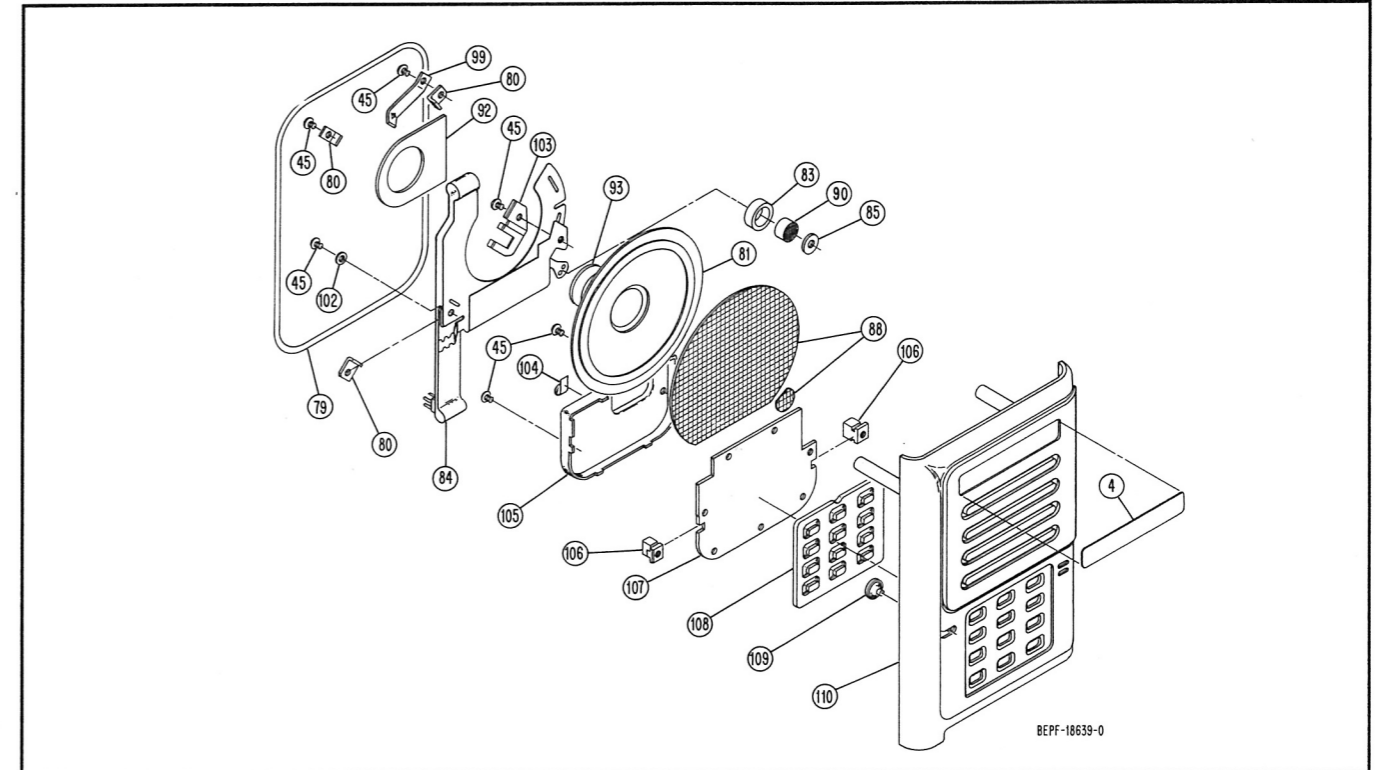

**NTN4958A Multicall Front Cover
Exploded View Parts List**

TPLF-3601-O

REFERENCE SYMBOL	MOTOROLA PART NO.	DESCRIPTION
Note: Motorola part number and description of Multicall Exploded View items (ITEM NO.s 4 to 83, 85, 90, 92, 93, 99, and 102) correspond to those of the standard radio Exploded View and Exploded View Parts List. The following items are unique to Multicall Front Cover.		
84	0105956P58	ASSEMBLY, Multicall Microphone Flex
88	3505152J01	FELT, Speaker
103	4205167S01	RETAINER, Microphone
104	3905509R02	CONTACT
105	2605164S01	SHIELD, Circuit Board
106	-----	* INSERT, Shield (2 req'd)
107	-----	* CIRCUIT BOARD, Multicall
108	-----	* SWITCH, Keypad
109	-----	* SWITCH, Actuator
110	-----	* COVER, Front

* Not field replaceable, order Multicall Front Cover Kit NTN4958A.

MANUAL REVISION

for
Manual No. 68P81046C70-O
HT800 Handie-Talkie Portable Radios

This revision outlines changes that have occurred since the printing of your manual. Use this information to supplement your manual. Installation of these changes in earlier equipment is not necessary except as recommended in Motorola Service and Repair Notes (SRN's).

REVISION DETAILS

<u>ITEM NO.</u>	<u>CHANGE AFFECTS</u>	<u>ITEM NO.</u>	<u>SUFFIX</u>
1 thru 12	General Information	-----	-----
13, 14	Electrical Parts List	NUD6891A	-----
		NUD6901A	-----
		NUD6961A	-----
		NUD6971A	-----

CHANGES

ITEM NO.

- On page 1, **SPECIFICATIONS, GENERAL**,
 - change High Capacity HEIGHT dimension from 177.3mm (6.98 ") to read: 184.4mm (7.26").
 - change High Capacity WEIGHT specification from 684g (24.1 oz) to read: 686g (24.2 oz).
 - change the frequency range from 146 -174MHz to read: 136 - 174MHz.
- On page 4, **SERVICE AIDS**, change the Motorola part number of:
 - Programmer /Tuner Software (5 1/4" floppy disc) from EVN-4101A to read: RVN4031A
 - Programmer /Tuner Software (3 1/2" floppy disc) from EVN-4103A to read: RVN4032A
- On page 5, **RECOMMENDED TOOL LIST, HEAT FOCUS HEADS**
 - change the description of the first heat focus head to read: 0.318" x 0.318" for U402
 - at the bottom of the list, add the following:

66-80370B57	0.245" x 0.245" for U403, U703, U801, and U901
66-80370B66	0.180" x 0.180" for U704
66-80371B23	0.160" x 0.275" for U702
66-80370B58	0.340" x 0.340" for U701 (Continuous Tone DTMF)
66-80334B54	0.160" x 0.425" for U902
- On page 9, **RECEIVER ALIGNMENT, Preliminary Adjustments**:
 - delete step 3
 - change step 4 to read step 3
 - change step 5 to read step 4
- On page 9, **RECEIVER ALIGNMENT, Receiver Check**, change step 7 to read:
If the rf level required to produce 12dB SINAD is 0.40 μ V or less, DO NOT REALIGN THE RECEIVER; instead, proceed directly to "Squelch Sensitivity/Check Adjustment." If the rf level required to produce 12dB SINAD is greater than 0.40 μ V, perform the "Receiver Alignment."
- On page 10, **Narrow Bandwidth (6MHz or less)**, change step 8 to read:
Tune coils L1, L3, L4, and L5 flush with the solder side (side 2) of the PC board.

ITEM NO.

7. On page 11, **WideBandwidth (Greater than 6MHz)**, supplement steps 15, 16, 18, and 20 with the following:

15. Tune coils L1, L3, L4, and L5 flush with the solder side (side 2) of the PC board.
16. Use the Programmer/Tuner to program the receiver frequency for 147.125 ± 0.1 MHz for low split radios (136 - 151 MHz), or 158.125 ± 0.1 MHz for mid split radios (146 - 162 MHz), or 170.125 ± 0.1 MHz for high split radios (157- 174 MHz). If interference is present, program for a receive frequency as close to the desired frequency as possible.
18. Use the Programmer/Tuner to program the receiver frequency for 150.975 ± 0.1 MHz for low split radios (136 - 151 MHz), or 161.975 ± 0.1 MHz for mid split radios (146 - 162 MHz), or 173.975 ± 0.1 MHz for high split radios (157- 174 MHz).
20. Use the Programmer/Tuner to program the receiver frequency for 136.125 ± 0.1 MHz for low split radios (146 - 151 MHz), or 136.125 ± 0.1 MHz for mid split radios (146 - 162 MHz), or 173.975 ± 0.1 MHz for high split radios (157- 174 MHz).

8. On page 11, **Squelch Sensitivity Check/Adjustment**:

- delete steps 6 through 16
- add the following steps, 6 through 13
 6. Proceed to the **CARRIER SQUELCH** position in the **TUNE RADIO** screen.
 7. Turn the rf of the generator or monitor on at the minimum possible level. Increase the rf level until squelch break occurs. Note the quieting level at squelch break. If squelch break occurs between 7 and 16 dB of quieting, proceed directly to step 10. If the quieting level is not within the 7 to 16 dB range, continue with step 8.
 8. Press the \pm keys to adjust the carrier squelch to 0. Adjust the rf level for 8 dB of quieting.
 9. Holding the rf level constant, press the + key to increase the carrier setting one step at a time until the radio squelches. This will be the carrier squelch setting.
 10. Proceed to the **TONE SQUELCH** position in the **TUNE RADIO** screen.
 11. Adjust the tone squelch setting to the same value used for the carrier squelch setting.
 12. Exit from the **RADIO ALIGNMENT** and **SERVICE AIDS** menu.
 13. If the squelch setting required modification, program the radio.

9. On page 12, change the title **Cloning Procedure** to read:
Cloning Procedure (2- and 8-Channel Radios):

On page 12, add the following cloning procedure for 16-channel radios.

Cloning Procedure (16-Channel Radios):

(The content of radio A is to be duplicated into radio B)

1. Connect the cloning cable (NKN6376A) to the Universal Connector of both radio A and radio B.
2. Turn off radio A and position the channel selector switch to channel 1. Turn on radio B.
3. Place the decode select switch on radio A to the coded squelch position for partial cloning. Cloning will duplicate the content of radio A into radio B, except for the deviation and squelch settings.
4. Simultaneously depress the PTT (push-to-talk button) and the monitor button of radio A and hold.
5. Turn on radio A. The green LED on radio B will flash, indicating cloning is in progress.
6. This step of cloning is complete once the green LED turns off and an alert tone is heard from radio B. Release both the monitor button and the PTT on radio A.
7. Turn off radio A and position the channel selector to channel 16. Radio B should still be on.
8. Simultaneously depress the PTT and the monitor button of radio A and hold.
9. Turn on radio A. The green LED on radio B will flash, indicating cloning is in progress.
10. This final step of cloning is complete once the green LED turns off and an alert tone is heard from radio B. Release both the monitor button and the PTT on radio A.

10. On page 42, Exploded View Parts List, change the part number of item 8 to 0102700J04.

11. On page 44, Exploded View Parts List, the following parts have change and need to be added to the parts list:

<u>Item No.</u>	<u>Action</u>	<u>Part Number</u>	<u>Description</u>
82	Changed to	4202036J01	RETAINER, Microphone
83	Changed to	0484345A06	WASHER, Seal

12. On page 40, supplement the Controller Flex Parts List with the accompanying Controller Flex parts List TPLF-3555-A.

13. **HT800** "Handie-Talkie" radios are available in the 136-151MHz (low split) frequency range. New transceiver circuit kits are as follows:

Kit Number	Power Output	Channel Spacing
• NUD6891A	1- and 2-Watt	12.5KHz
• NUD6901A	5-Watt,	12.5KHz
• NUD6961A	1- and 2-Watt,	20/25KHz
• NUD6971A	5-Watt	20/25KHz

14. On page 40, supplement the Transceiver Electrical Parts List with the accompanying Transceiver Electrical Parts List TPLF-3554-A.

Electrical Parts List

L= 136-151MHz

M = 146-162MHz

H = 157-174MHz

TPLF-3554-A

REFERENCE SYMBOL	MOTOROLA PART NO.	DESCRIPTION
		CAPACITOR, Fixed: pF±5% 50V unless stated
C1	2160520S09 or 2113740A42 or 2113740A39	22 (L) 36 (M) 27 (H)
C2	2113740A32 or 2113740A37	13 (L) 22 (M)
C3	or 2113740A27 2113740A15 or 2113740A19 or 2113740A13	8.2 ±0.25pF (H) 3.3 ±0.25pF (L) 4.7 ±0.25pF (M) 2.7 ±0.25pF (H)
C4	2113740A34 or 2113740A35	16 (L, H) 18 (M)
C5	2113740A36 or 2113740A33 or 2113740A34	20 (L) 15 (M) 16 (H)
C6	2113741A43	8200
C8	2113740A23	6.2 ±0.25pF
C9	2113740A75 or 2113741A17	680 (L, M) 680 ±10% (H)
C10	2113740A05 or 2113740A03	1.2 ±0.25pF (L) 1.0 ±0.25pF (M, H)
C11	2113740A25 or 2113740A23 or 2113740A24	7.5 ±0.25pF (L) 6.2 ±0.25pF (M) 6.8 ±0.25pF (H)
C12	2113740A05 or 2113740A03	1.2 ±0.25pF (L) 1.0 ±0.25pF (M, H)
C13	2113740A06 or 2113740A31	13 (L, H) 12 (M)
C14	2113740A32 or 2113740A29	13 (L) 10 (M)
C15	or 2160520S02 2113740A28	11 ±0.25pF (H) 8200
C16, 17	2113740A75 or 2113741A17	680 (L, M) 680 ±10% (H)
C18	2113741A43	8200
C19	2113740A43 or 2160523F22 or 2160523F44	39 (L) 39 (M) 43 (H)
C20	2160520A17 or 2113740A19	4.7 ±0.25pF (L, M) 8.2 ±0.25pF (H)
C21	2113740A75 or 2113740A17	680 (M) 680 ±10% (H)
C22	2113741A43	8200
C24	2113740A32	13
C25	2113740A13 or 2160523F40 or 2160523F06	2.7 ±0.25pF (L) 2.7 ±0.25pF (M) 3 (H)
C26	2113740A38	24
C27	2160520S01 or 2160523F15	10 ±0.25pF (L) 10 (M, H)
C30	2113740A18 or 2113740A21 or 2113740A27	4.3 ±0.25pF (L) 5.6 ±0.25pF (M) 8.2 ±0.25pF (H)
C31	2113740A75 or 2113741A17	680 (M) 680 ±10% (H)
C32	2113740A05	1.2 ±0.25pF
C33	2113740A75 or 2113741A17	680 (L, M) 680 ±10% (H)
C35	2113740A21 or 2113740A23 or 2113740A27	5.6 ±0.25pF (L) 6.2 ±0.25pF (M) 8.2 ±0.25pF (H)
C36	2113740A75 or 2113741A17	680 (M) 680 ±10% (H)
C37	2160520S01 or 2160523F15	10 ±0.25pF (L) 10 (M, H)
C39	2113741A43	8200
C42	2113740A67	330
C43	2113741B49	.015µF±10%
C100	2113740A11 or 2113740A10 or 2113740A07	2.2 ±0.25pF (L, 5W) 2 ±0.25pF (2W), (M, 5W) 1.5 ±0.25pF (H, 5W)
C101	2113740A38 or 2113740A36 or 2113740A35	24 (L) 20 (M) 18 (H)

C102	2113740A41 or 2113740A38 or 2160520B09 or 2113740A40	33 (L, 2W) 24 (L, 5W) (M, 5W) 22 (H) 30 (M, 2W)
C107	2113740A49 or 2113740A52 or 2113740A48 or 2113740A51	56 (L, 2W) (H) 75 (L, 5W) 51 (M, 2W) 68 (M, 5W)
C108	2113740A67	330
C109	2113740A43 or 2113740A40 or 2113740A42 or 2113740A41	39 (L, 2W) 30 (L, 5W), (M, 5W) 36 (M, 2W) 33 (H)
C110	2160521G37	0.1µF + 10 - 20%
C111	2113740A46 or 2113740A48 or 2113740A44 or 2113740A43	47 (L, 2W), (M, 2W) 51 (L, 5W) 43 (M, 5W) 39 (H)
C112	2113740A54	91 (5W Models only)
C114	2113740A67 or 2160521G37	330 (L), (M), (H, 2W) 0.1µF+10-20% (H, 5W)
C115	2160521G37 or 2113740A67	0.1µF+10-20% (L) (M) (H, 2W) 330 (H, 5W)
C117	2113740A50 or 2113740A55 or 2113740A49 or 2113740A53 or 2113740A19 or 2113740A52	62 (L, 2W) 100 (L, 5W) 56 (M, 2W) 82 (M, 5W) 47 (H, 2W) 75 (H, 5W)
C118	2113740A37 or 2113740A35 or 2113740A36 or 2113740A31 2113740A32 2113740A33	22 (L, 2W) 18 (L, 5W) 20 (M, 2W) 12 (M, 5W) 13 (H, 5W) 15 (H, 2W)
C119	2113740A35 or 2113740A33 or 2113740A37 or 2113740A31 or 2113740A36 or 2113740A27	15 (L, 5W) 22 (M, 2W) 12 (M, 5W) 20 (H, 2W) 8.2 (H, 5W)
C120	2005568P01	Trimmer, 5.5-65pF
C121	2113740A43 or 2113740A42	39 (L, M) 36 (H)
C122	2113740A38 or 2113740A36 or 2113740A35 or 2113740A33 or 2113740A32	24 (L, 2W) 20 (L, 5W) 18 (M, 2W) 15 (M, 5W), (H, 5W) 13 (H, 2W)
C123	2113740A36 or 2113740A35	20 (L, 2W), (M) 18 (L, 5W), (H)
C130	2113740A67 or 2113740A21	330 (L, 2W), (M, 2W), (H) 3300 (L, 5W), (M, 5W)
C131	2113740A67	330
C132	2113740A67 or 2113740A75	330 (L, 2W), (M, 2W), (H) 680 (L, 5W), (M, 5W)
C133	2160521G37	0.1µF + 80 - 20%
C134	2113740A18	4.3 ± 0.25pF (H, 5W Models only)
C140	2113740A18 or 2113740A19 or 2113740A14 or 2113740A15	4.3 ±0.25pF (L, 2W) 4.7 ±0.25pF (L, 5W) 3 (M, 2W) 3.3 ±0.25pF (M, 5W), (H)
C142	2113740A42 or 2113740A49 2113740A38 or 2113740A44 or 2113740A35 or 2113740A39	36 (L, 2W) 56 (L, 5W) 24 (M, 2W) 43 (M, 5W) 18 (H, 2W) 27 (H, 5W)
C143	2113740A33 or 2113740A37 2113740A31 or 2113740A35 or 2113740A34 or 2113740A29	15 (L, 2W) 22 (L, 5W) 12 (M, 2W) 18 (M, 5W) 16 (H, 5W) 10 (H, 2W)
C145	2113740A36 or 2113740A34 or 2113740A32	20 (L) 16 (M) 13 (H)
C146	2113740A67 or 2160521G37	330 (2W Models) (H, 5W) 0.1µF + 80 - 20% (M, 5W)
C147	2113740A67	330 (2W Models only)
C148	2113740A67	330
C149	2113740A35 or 2113740A37 or 2113740A32 or 2113740A33	18 (L, 2W), (M) 22 (L, 5W) 13 (H, 2W) 15 (H, 5W)
C150	2113740A67	330

C151	2113740A50 or 2113740A43 or 2113740A46	62 (L) 39 (M) 47 (H)
C152	2113740A37 or 2113740A35 or 2113740A33 or 2113740A67	22 (L) 18 (M) 15 (H) 330
C153	2113741B49	0.015 μ F \pm 10%
C154	2113741A25	1500
C200 thru 202	2160521G37	0.1 μ F + 80 - 20%
C204	2113740A67	330
C203, 205, 206	2305458G12	33 μ F; 16V
C207	2113741A21	1000
C209	2113741A27	1500
C210 thru 213	2113740A53	82
C301 thru 303	2113740A49	56
C304, 305	2113740A53	82
C306, 307	2113740A53	82
C309, 311	2113740A67	330
C310	2113740A67	330
CR1	4883654H06	DIODE: See Note 1
CR2	4805490G02	Silicon
CR101	4883654H01	Silicon
CR102	4805129M61	18V, ZENER
CR301A, 301B	4805729G24	LED, Bicolor
E101	7683960B04	CORE:
E102	7683960B01	Ferrite Bead
F1	6505214E02	Ferrite Bead
FL1, 2	4805245J20 or 4805245J19	FUSE: Axial, 5-Amp.
FL3	9105725Q03	FILTER:
FL4	9105726Q02 or 9105726Q04	Crystal, 53.55MHz Crystal, 53.55MHz (12.5 kHz channel spacing only) Ceramic, 450kHz Ceramic, 450kHz Ceramic, 450kHz (12.5 kHz channel spacing only)
L1	2405669G13 or 2405669G12	COIL, RF: unless stated 5-1/2 turns, spacewound (L) 4-1/2 turns, spacewound (M), (H)
L2	2405669G31 or 2405669G30	5-1/2 turns, spacewound (L) 4-1/2 turns, spacewound (M), (H)
L3, 4, 5	2405523P29 or 2405523P18	9-1/2 turns, closewound; with core (L) 8-1/2 turns, closewound; with core (M), (H)
L6	2405063H13	Tunable, 1.2 μ H Choke
L7, 8	2405063H05	Tunable, 0.4 μ H Choke
L9	2405523P28 or 2405523P10 or 2405523P09	6-1/2 turns, spacewound (L) 5-1/2 turns, spacewound (M) 4-1/2 turns, spacewound (H)
L10	2405523P10 or 2405523P09 or 2405523P08	5-1/2 turns, spacewound (L) 4-1/2 turns, spacewound (M) 3-1/2 turns, spacewound (H)
L11	2482723H38	1.2 μ H Choke
L12	2505129C02	1.2 μ H Choke, precision
L101	2482723H28 or 0105951P49	0.29 μ H Choke (2W), (H, 5W) Assy., 0.29 μ H Choke (L, 5W), (M, 5W)
L102	2405523P28	6-1/2 turns, spacewound
L103	2482723H38	1.2 μ H Choke
L104	2405523P32	9-1/2 turns, closewound
L105	2405523P07	2-1/2 turns, spacewound
L106	2405913C01	3-turn ferrite bead
L107	0105951P49 or 0105951P48	Assy., 0.29 μ H Choke and bead (2W) Assy., .085 μ H Choke and bead (5W)
L108	2405523P07 or 2405559P09	2-1/2 turns, spacewound (2W) 1-1/2 turns, airwound (5W Models)
L109	2405913C01	3-turn ferrite bead
L110	0105951P48	Assy., .085 μ H Choke and bead (5W)
L111	2405559P07 or 2405539P08	2-1/2 turns, airwound (2W) 1-1/2 turns, airwound (5W)
L112	2405559P11 or 2405559P21	4-1/2 turns, airwound (L), (M), (H, 2W) 4-1/2 turns, airwound (L), (M), (H, 5W)

L113, 114	2405559P01 or 2405559P02	6-1/2 turns, airwound (L), (M) 5-1/2 turns, airwound (H)
L115	2405559P01 or 2405559P02	6-1/2 turns, airwound (L), (M) 5-1/2 turns, airwound (H)
L116, 117	2482723H38	1.2 μ H Choke
L119, 120	2405559P01 or 2405559P02	6-1/2 turns, airwound (L), (M) 5-1/2 turns, airwound (H)
L201	2405452C70	190 μ H Choke
LS1	5005155Q03	TRANSDUCER
MK1	0105956P37	MICROPHONE ASSEMBLY:
P1	2805572P01	PLUG:
P2	2805572P01	Connector, Flex Top; 13-pin
P3	2805144Q01	Connector, Flex Top; 13-pin
P4	2805144Q01	Connector, Synthesizer; 7-pin
P5	2805433R02	Connector, Synthesizer; 7-pin
P6	2805247Q01	Connector, Front Cover
P7	-----	Connector, I-F
Q1	4805218N08	Not field replaceable, order
Q2	4805452G08	Top Control Panel Assembly 0105951N41
Q3	4805218N09	TRANSISTOR: See Note II
Q101, 102	4805218N09	NPN
Q103	4805474G37	Dual Gate MOSFET; Type
Q104	4805452G06 or 4805474G33	M52G08 NPN NPN NPN; Type M74G37 NPN; Type M52G06 (2W) NPN; Type M74G33 (5W)
R1	0660076A67	RESISTOR, Fixed: W \pm 5%;
R2	0660076A87	1/10W unless stated
R3	0660076A59	5.6k
R6	0660076A49	39k
R7	0660076A73	2.7k
R9	0660076A45	1k
R10	0660076A56	10k
R13	0660076A71	680
R14	0660076A84	2k
R15	0660076A71	8.2k
R16	0660076A36 or 0660076A31 or 0660076A36 or 0660076A25	330 (L) 20/25KHz Ch. Sp. 180 (M) 20/25KHz Ch. Sp. 560 (H) 20/25KHz Ch. Sp. 100
R17	0660076A71	8.2k
R100	0660076A84	30k
R101	0660076A84	30k
R102	0660076A65	4.7k
R103	0660076A69	6.8k (L), (M, 5W), (H, 5W)
R104	0660076A68 or 0660076A82 or 0660076A84 or 0660076A79 or 0660076A25 or 0660076A26	6.2k (M, 2W), (H, 2W) 24k (L), (M, 5W), (H, 5W) 30k (5W Models) 18k (H, 2W) 100 (L), (M, 2W) 110 (M, 5W), (H, 5W)
R105	0660076A32 or 0660076A36 or 0660076A75 or 0660076A67 or 0660076A73	200 (H, 2W) 12k (L) 5.6k (M, 2W), (H) 10k (M, 5W)
R106	0660076A17 or 0660076A73 or 0660076A17	47 (2W) 100 (L, 5W) 82 (M, 5W), (H, 5W)
R108	0660076A25 or 0660076A23 or 0660076A17 or 0660076A07 or 0660076A09 or 0660076A46	18 (L, 5W) 22 (M, 5W) 750
R109	0660076A29 or 0660076A29	150 (5W Models) Not used on 2W Models
R111	0660076A29	150
R112	0660076A71	8.2k
R127	1805559S02	Pot., 50k
R128	0660076A87	39k
R129	0660076A87	150 (L, 2W Models only)
R130	0660076A29	Pot., 5k
R131	1805100Q03	SWITCH:
R140	-----	On/Off, Part of R140
S1	-----	
S2	4005148Q02 or 4005265Q02	2- & 8-channel radios 16-channel radios
S3	4005101Q01	Toggle, SPDT
S301	3905834K01	Snap Dome, Monitor
S302	3905834K01	Snap Dome, PTT
S303	3905834K01	Snap Dome, Monitor

REFERENCE SYMBOL	MOTOROLA PART NO.	DESCRIPTION
		CAPACITOR, Fixed: pF ±5% 50V unless stated
C400	2113741B33	3300 ± 10%
C401	2360562A07	0.47; 25V
C403	2160521G37	0.1 +80 - 20%
C404	2360562A28	4.7µF; 10V
C405, 406	2111032B13	0.1 +80 - 20%
C408	2113741A37	.0047 ± 10%
C410	2360562A07	0.47; 25V
C415	2360562A43	10µF; 16V
C416	2160521G37	0.1
C420	2360562A13	1µF; 16V
C421	2113740A29	10 ±30%
C422	2113740B29	15
C423	2113740A55	100 ±30%
C424	2160521G37	0.1 +80 - 20%
C426	2113740A55	100 ±30%
C431	2160521G37	0.1 +80 - 20%
C442, 443, 444	2360562A13	1µF; 16V
C445	2369562A35	10µF; 25V
C446	2113741A39	5600
C447	2113741A31	2700
C448	2113741A45	.01µF
C449	2111032B13	0.1µF +80 - 20%
C452	2360562A28	4.7µF; 10V
C453	2360562A43	10µF; 16V
C456 thru 460	2113740A59	150 ±30%
C466, 467	2113740A53	82
C470	2113741A45	.01µF
C471	2360562A13	1.0µF; 16V
C472	2113740B47	82
C481	2360562A43	10µF; 16V
C483, 484	2113741A21	1000
C485	2113740B47	82
C486	2360562A13	1µF; 16V
C488, 489	2160521G37	0.1µF + 80 - 20%; 25
C490	2113741A45	.01µF
C491, 492	2113741A53	.022µF
C493, 494	2160521G37	.1µF
C497	2113741A53	.022µF
C498	2113741A37	.0047µF
C499	2113741A45	.01µF
C801	2113740B25	3300
C802	2111032B13	0.1µF +80 - 20%
C803	2160520P08	2000
C804	2113740B61	330
C805	2113740B31	.01µF
C806	2111032B13	0.1 +80 - 20%
CR403, 404, 405	4805494Q04	DIODE: See Note Silicon
CR409, 410, 411	4805494Q04	Silicon
J1	0905573P02	JACK: Connector, Controller Flex Top; 13-pin
J2	0905573P02	Connector, Controller Flex Top; 13-pin
J3	0905577P01	Connector, Synthesizer; 7-pin
J4	0905577P01	Connector, Synthesizer; 7-pin
J5	0905504R01	Connector, 10-pin
J6	0105959M27	Header Assembly, 13-pin
J7	-----	Not field replaceable, order Volume Pot. Flex 0105956M66
L400 thru 409	2462575A01	COIL, RF: unless stated 0.39µH Choke
L410	2460590A02	150µH Choke
L411 thru 415	2462575A01	0.39µH Choke
Q400	4805128M94	TRANSISTOR: See Note II PNP
Q401	4805128M12	NPN
Q402, 403, 404	4805128M94	PNP
Q405, 406	4805128M12	NPN
Q407	4805128M94	PNP
Q410	4805128M10	PNP
Q412	4805128M94	PNP
Q413	4805128M12	NPN
Q414	4805128M94	PNP
Q415, 416, 420	4805128M12	NPN

R400	0611077B23	RESISTOR, Fixed: Ω ± 5%; 1/8W unless stated
R401, 402	0611077A98	100k
R403	0611077A92	10k
R404	0611077A98	5.6k
R405	0660076K49	10k
R406, 407, 408	0611077B23	10 Meg ± 10%
R409	0611077A72	100k
R410	0611077A84	820
R411	0611077A98	2.7k
R412, 413	0611077B23	10k
R414	0611077B16	100k
R417	0611077A81	51k
R419	0660076A56	2k
R421	0611077A66	2k
R422	0611077A76	470
R423	0611077B09	1.2k
R424	0611077A78	27k
R425	0660076F01	1.5k
R426	0660076E84	100k ± 1%
R427	0660076A94	30k ± 1%
R428	0660076B05	75k; 1/10W
R429	0660076B01	150k
R430	0611077A98	100k
R434	0611077A66	10k
R438	0611077B23	470
R439	0611077A98	100k
R440	0660076A73	10k
R441	0660076B25	10k
R443	0611077B23	1 Meg
R446	0611077A50	100k
R447	0611024J08	100
R448	0611024H84	158k ± 1%
R449	0611077A26	90.9k ± 1%
R450	0611077A98	10
R451	0611077B15	10k
R452	0611077A79	47k
R453, 454	0611077A74	1.6k
R462	0660076A73	1k
R466	0660077A98	10k
R467	0611077A84	10k
R470	0611077A50	2.7k
R472	0611077A50	100
R480, 461	0611077B23	100
R481	0611077A98	100k
R482	0611024J09	10k
R483	0611024H88	175k±1%
R484	0611024H09	100k
R485	0660076E90	15k
R486, 487	0611077A82	51k±1%
R801, 802	0611024J73	2.2k
R803	0611024J14	750k
R804	0611077B26	182k
R805	0611077B11	130k
R806, 807	0611077A96	33k
R808	0611077B47	8.2k
		1 Meg
		CIRCUIT MODULE:
U401	0105952Q59	See Note I
U402	0105958N07	Microcomputer
U403	0105956M87	EEPROM
U405	0105951Q59	Hex Gate
U406	0105958P03	Audio Filter
U407	5160880B01	Audio PA
U801	0105957N83	5V Regulator, CMOS Quad Op-Amp
VR401, 402	4880140L09	DIODE: See Note I
VR407-409	4880140L09	Zener, 6.2V
		Zener, 6.2V
Y401	* 4805664G33	CRYSTAL: See Note II 3.6864MHz

NOTES:

- I. For optimum performance, order replacement diodes, transistors, and circuit modules by Motorola part number only.
- II. When ordering crystal units, specify carrier frequency, crystal frequency, crystal type number, and Motorola part number.

U1	5105549S01 5105729E90	CIRCUIT MODULE: See Note I I-F I-F (12.5kHz channel spacing only)
U103 U104	5105822P51 5105822P64 or 5105729E93	Antenna Switch Antenna Selector (2W) Antenna Selector (5W)
U106	5105729E52 5105729E72	Ref. Oscillator Ref. Oscillator (12.5kHz channel spacing only)
U201	5105822P61 or 5105822P60 or 5105822P59	VCO (L) VCO (M) VCO (H)
U202	5102001J03	Synthesizer
VR102 VR301	4805129M61 4805129M42	DIODE: See Note I Zener, 18V Zener, 5.6V
NONREFERENCED ITEMS		
	0200007007 0300136771 0705196A04 0705766R01 1400861196 1405238Q01 1405496B01 2605116S01 2605494B01 2605524P01 2605524P03 2605532P01 2605578P01 2605820D07 2683379H01 3905130N01 3905509R02 7505295B07 7505695R01 8405589P03 8405591P03	NUT, Hex; 8-32 X 1/4" X 3/32" (for Q104, 5W Models) SCREW, Phillips; 2-56 X 3/16" (for Q104 heatsink) BOOT, for FL1, FL2 SUPPORT, Rubber INSULATOR, for Q103 INSULATOR, for U106 INSULATOR (I-F) SHIELD, P.A. Output SHIELD, I-F Module CAN, for L11, L12 CAN, for L111 thru L115, L119, L120, and L108 (5W Models) HEAT SINK, for Q104 (5W Models) HEAT SINK, for Q104 (2W Models) CAN, for L1, L2 HEAT SINK, for Q103 CONTACT STRIP CONTACT PAD, for FL1, FL2 CUSHION, for U106 PC BOARD (2W) PC BOARD (5W)

NOTES:

- I. For optimum performance, order replacement diodes, transistors, and circuit modules by Motorola part number only.
- II. When ordering crystal units, specify carrier frequency, crystal frequency, crystal type number, and Motorola part number.

* Not field replaceable, order microphone flex assembly 0105956P37.



MOTOROLA INC.

**MANUAL REVISION
for
HT800 Portable Radios
Manual No. 68P81046C70-O**

On page 42, replace the **EXPLODED VIEW DIAGRAM** with the following:

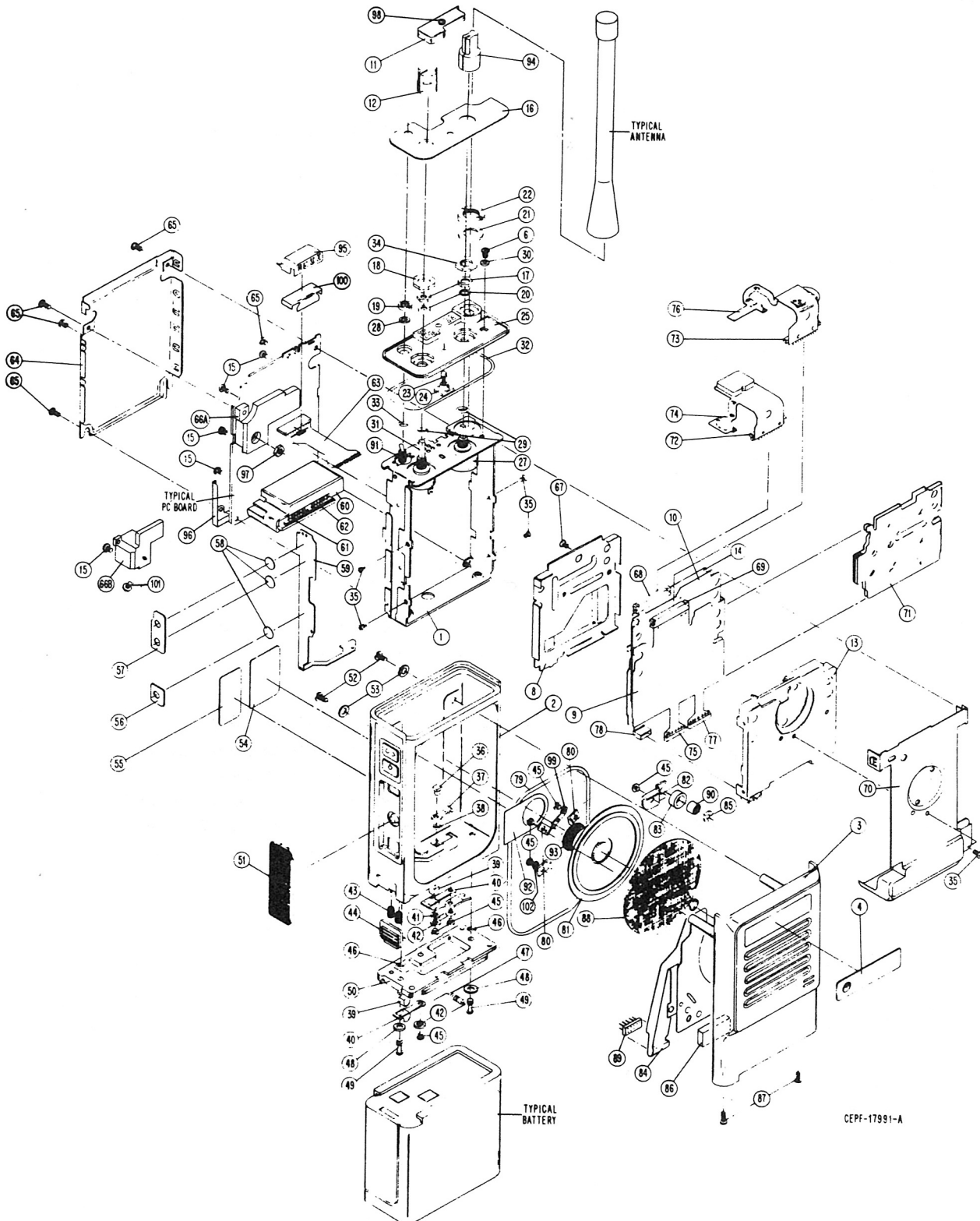



MOTOROLA INC.

MANUAL REVISION

for

Manual No. 68P81046C70-O
HT800 Handie-Talkie Portable Radios

This revision outlines changes that have occurred since the printing of your manual. Use this information to supplement your manual. Installation of these changes in earlier equipment is not necessary except as recommended in Motorola Service and Repair Notes (SRN's).

REVISION DETAILS

<u>ITEM NO.</u>	<u>CHANGE AFFECTS</u>	<u>ITEM NO.</u>	<u>SUFFIX</u>
1	Transceiver, Electrical Parts List	NUD6891B	-----
		NUD6892B	-----
		NUD6893B	-----
		NUD6901B	-----
		NUD6902B	-----
		NUD6903B	-----
		NUD6961B	-----
		NUD6962B	-----
		NUD6963B	-----
		NUD6971B	-----
		NUD6972B	-----
2	Controller Flex, Controller Flex Parts List	NTN5374B	-----

CHANGES

ITEM NO.

1. New transceiver "B" kits supersede the corresponding existing "A" kits. The new "B" kits include many component value changes. Supplement the existing Electrical Parts List with the accompanying Electrical Parts List, **TPLF-3554-B**.

2. A new Controller Flex, **NTN5374B**, supersedes the corresponding existing "A" kit. The new Controller Flex includes many component value changes. Supplement the existing Controller Flex Electrical Parts List with the accompanying Controller Flex Electrical Parts List, **TPLF-3555-B**.

The new Controller Flex includes the addition of a 330pF chip capacitor, C438, Motorola part number 2113740A67. Electrically, C438 is tied from the collector of Q403 to ground. Physically, C438 is located on the component side of the Controller Flex between Q403 and C483.

Electrical Parts List

L = 136-151MHz

M = 146-162MHz

H = 157-174MHz

12KHz = 12KHz Channel Spacing

20/25 KHz = 20/25KHz Channel Spacing TPLF-3554-B

REFERENCE SYMBOL	MOTOROLA PART NO.	DESCRIPTION
		CAPACITOR, Fixed: pF±5% 50V unless stated
C1	2160520S09 or 2113740A42 or 2113740A23 or 2113740A39	22 (L) 36 (M) 6.2 ±0.25pF (H, 12.5KHz) 27 (H, 20/25KHz)
C2	2113740A32 or 2113740A37 or 2113740A21 or 2113740A27	13 (L) 22 (M) 5.6 ±0.25pF (H, 12.5KHz) 8.2 ±0.25pF (H, 20/25KHz)
C3	2113740A15 or 2113740A19 or 2113740A11 or 2113740A13	3.3 ±0.25pF (L) 4.7 ±0.25pF (M) 2.2 ±0.25pF (H, 12KHz) 2.7 ±0.25pF (H, 20/25KHz)
C4	2113740A34 or 2113740A35 or 2113740A32	16 (L), (H, 20/25KHz) 18 (M) 13 (H, 12.5KHz)
C5	2113740A36 or 2113740A33 or 2113740A34	20 (L) 15 (M) 16 (H)
C6	2113741A43	8200
C8	2113740A23	6.2 ±0.25pF
C9	2113740A75	680 (L,M)
C10	or 2113741A17 2113740A04 or 2113740A03	680 ±10% (H) 1.1 ±0.25pF (L) 1.0 ±0.25pF (M, H)
C11	2113740A25 or 2113740A23 or 2113740A24	7.5 ±0.25pF (L) 6.2 ±0.25pF (M) 6.8 ±0.25pF (H)
C12	2113740A04 or 2113740A03 2113740A32	1.1 ±0.25pF (L) 1.0 ±0.25pF (M, H) 13 (L, H)
C13	or 2113740A31 2113740A32 or 2113740A29	12 (M) 13 (L) 10 (M)
C14	or 2160520S02 2113741A43 2113740A75	11±0.25pF (H) 8200 680 (L, M)
C15	or 2113741A17	680 ±10% (H)
C16, 17	2113741A43	8200
C18	2113740A43	39 (L)
C19	or 2160523F22 or 2160523F44	39 (M) 43 (H)
C20	2160520A19 or 2113740A23 or 2113740A27	4.7 ±0.25pF (L) 6.2 ±0.25pF (M) 8.2 ±0.25pF (H)
C21	2113740A75 or 2113740A17	680 (L, M) 680 ±10% (H)
C22	2113741A43	8200
C24	2113740A35	18
C26, 27	2113740A40	30
C30	2113740A18 or 2113740A21 or 2113740A27	4.3 ±0.25pF (L) 5.6 ±0.25pF (M) 8.2 ±0.25pF (H)
C31	2113740A75 or 2113741A17	680 (L, M) 680 ±10% (H)
C32	2113740A05	1.2 ±0.25pF
C33	2113740A75	680 (L,M)
C35	or 2113741A17 2113740A21 or 2113740A23	680 ±10% (H) 5.6 ±0.25pF (L) 6.2 ±0.25pF (M)
C36	or 2113740A27 2113740A75 or 2113741A17	8.2 ±0.25pF (H) 680 (L, M) 680 ±10% (H)
C37	2160520S01 or 2160523F15	10 ±0.25pF (L) 10 (M, H)
C39	2113741A43	8200
C42	2113740A67	330
C43	2113741B49	.015µF±10%
C100	2113740A12 or 2113740A11 or 2113740A10 or 2113740A08	2.4 ±0.25pF (L, 2W) 2.2 ±0.25pF (L, 5W) 2 ±0.25pF (M), (H, 2W) 1.6 ±0.25pF (H, 5W)

C101	2113740A36 or 2113740A38 or 2113740A35 or 2113740A33	20 (L, 2W), (M) 24 (L, 5W) 18 (H, 2W) 15 (H, 5W)
C102	2113740A41 or 2113740A38 or 2113740A37 or 2113740A40	33 (L, 2W) 24 (L, 5W), (M, 5W) 22 (H, 2W) 30 (M, 2W), (H, 5W)
C107	2113740A49 or 2113740A52 or 2113740A48 or 2113740A51	56 (L, 2W) (H) 75 (L, 5W) 51 (M, 2W) 68 (M, 5W)
C108	2113740A67	330
C109	2113740A43 or 2113740A40 or 2113740A42 or 2113740A41	39 (L, 2W) 30 (L, 5W), (M, 5W) 36 (M, 2W) 33 (H)
C110	2160521G37	0.1µF + 80 - 20%
C111	2113740A46 or 2113740A48 or 2113740A44 or 2113740A43	47 (L, 2W), (M, 2W) 51 (L, 5W) 43 (M, 5W) 39 (H)
C112	2113740A54	91 (5W Models only)
C114	2113740A67	330 (L), (M), (H, 2W)
C115	or 2160521G37 2160521G37 or 2113740A67	0.1µF+80-20% (H, 5W) 0.1µF+80-20% (L) (M) (H,2W) 330 (H, 5W)
C117	2113740A51 or 2113740A55 or 2113740A49 or 2113740A53 or 2113740A46 or 2113740A52	68 (L, 2W) 100 (L, 5W) 56 (M, 2W) 82 (M, 5W) 47 (H, 2W) 75 (H, 5W)
C118	2113740A37 or 2113740A35 or 2113740A36 or 2113740A31	22 (L, 2W) 18 (L, 5W) 20 (M, 2W) 12 (M, 5W)
C119	2113740A32 2113740A33 2113740A38 or 2113740A33 or 2113740A37 or 2113740A31 or 2113740A36 or 2113740A27	13 (H, 5W) 15 (H, 2W) 24 (L, 2W) 15 (L, 5W) 22 (M, 2W) 12 (M, 5W) 20 (H, 2W) 8.2 (H, 5W)
C120	2005568P01	Trimmer, 5.5-65pF
C121	2113740A43 or 2113740A42	39 (M) 36 (H)
C122	2113740A36 or 2113740A35 or 2113740A33 or 2113740A32	20 (L) 18 (M, 2W) 15 (M, 5W), (H, 5W) 13 (H, 2W)
C123	2113740A36 or 2113740A35 2113740A67	20 (L, 2W), (M) 18 (L, 5W), (H) 330 (L, 2W), (M, 2W), (H)
C130	or 2113741A33 2113740A67	3300 (L, 5W), (M, 5W) 330
C131	2113740A67	330 (L, 2W), (M, 2W), (H)
C132	or 2113740A75 2160521G37	680 (L, 5W), (M, 5W) 0.1µF + 80 - 20%
C133	2113740A18	4.3 ± 0.25pF (H, 5W Models only)
C134		
C140	2113740A18 or 2113740A19 or 2113740A14 or 2113740A15	4.3 ±0.25pF (L, 2W) 4.7 ±0.25pF (L, 5W) 3 (M, 2W) 3.3 ±0.25pF (M, 5W), (H)
C142	2113740A42 or 2113740A49 2113740A38 or 2113740A44 or 2113740A35 or 2113740A39	36 (L, 2W) 56 (L, 5W) 24 (M, 2W) 43 (M, 5W) 18 (H, 2W) 27 (H, 5W)
C143	2113740A33 or 2113740A37 2113740A31 or 2113740A35 or 2113740A34 or 2113740A29	15 (L, 2W) 22 (L, 5W) 12 (M, 2W) 18 (M, 5W) 16 (H, 5W) 10 (H, 2W)
C145	2113740A36 or 2113740A34 or 2113740A32 2113740A67	20 (L) 16 (M) 13 (H) 330 (2W Models) (H, 5W)
C146	or 2160521G37 2113740A67 2113740A67	0.1µF + 80 - 20% (M, 5W) 330 (2W Models only) 330
C147	2113740A35	18 (L, 2W), (M)
C148	or 2113740A37 or 2113740A32	22 (L, 5W) 13 (H, 2W)
C149	2113740A33	15 (H, 5W)

C150	2113740A67	330
C151	2113740A50 or 2113740A43 or 2113740A46	62 (L) 39 (M) 47 (H)
C152	2113740A39 or 2113740A37 or 2113740A35 or 2113740A33	27 (L, 2W) 22 (L, 5W) 18 (M) 15 (H)
C153	2113740A67	330
C154	2113741B49	0.015 μ F \pm 10%
C200 thru 202	2113741A25	1500
C204	2160521G37	0.1 μ F + 80 - 20%
C203, 205, 206	2113740A67	330
C207	2305458G12	33 μ F; 16V
C209	2113741A21	1000
C210 thru 213	2113741A25	1500
C301 thru 303	2113740A53	82
C304, 305	2113740A49	56
C306, 307	2113740A53	82
C309, 311	2113740A53	82
C310	2113740A67	330
CR1	4883654H08	DIODE: See Note 1
CR2	4805490G02	Silicon
CR101	4883654H01	Silicon
CR102	4805129M61	Silicon
CR301A, 301B	4805729G24	18V, ZENER LED, Bicolor
E101	7683960B04	CORE: Ferrite Bead
E102	7683960B01	Ferrite Bead
F1	6505214E02	FUSE: Axial, 5-Amp.
FL1, 2	4805245J20 or 4805245J19	FILTER: Crystal, 53.55MHz Crystal, 53.55MHz (12.5 kHz channel spacing only)
FL3	9105725Q03	Ceramic, 450kHz
FL4	9105726Q02 or 9105726Q04	Ceramic, 450kHz Ceramic, 450kHz (12.5 kHz channel spacing only)
L1	2405669G13 or 2405669G12	COIL, RF: unless stated 5-1/2 turns, spacewound (L), (H, 12.5KHz) 4-1/2 turns, spacewound (M), (H, 20KHz)
L2	2405669G31 or 2405669G30	5-1/2 turns, spacewound (L), (H, 12.5KHz) 4-1/2 turns, spacewound (M), (H, 20KHz)
L3, 4, 5	2405523P29 or 2405523P18	9-1/2 turns, closewound; with core (L) 8-1/2 turns, closewound; with core (M), (H)
L6	2405063H13	Tunable, 1.2 μ H Choke
L7, 8	2405063H05	Tunable, 0.4 μ H Choke
L9	2405523P28 or 2405523P10 or 2405523P09	6-1/2 turns, spacewound (L) 5-1/2 turns, spacewound (M) 4-1/2 turns, spacewound (H)
L10	2405523P10 or 2405523P09 or 2405523P08	5-1/2 turns, spacewound (L) 4-1/2 turns, spacewound (M) 3-1/2 turns, spacewound (H)
L11	2482723H38	1.2 μ H Choke
L12	2505129Q02	1.2 μ H Choke, precision
L101	2482723H28 or 0105951P49	0.29 μ H Choke (2W), (H, 5W) Assy., 0.29 μ H Choke (L, 5W), (M, 5W)
L102	2405523P28	6-1/2 turns, spacewound
L103	2482723H38	1.2 μ H Choke
L104	2405523P32	9-1/2 turns, closewound
L105	2405523P07	2-1/2 turns, spacewound
L106	2405913C01	3-turn ferrite bead
L107	0105951P49 or 0105951P48	Assy., 0.29 μ H Choke and bead (2W) Assy., .085 μ H Choke and bead (5W)
L108	2405523P07 or 2405559P09	2-1/2 turns, spacewound (2W) 1-1/2 turns, airwound (5W Models)
L109	2405913C01	3-turn ferrite bead
L110	0105951P48	Assy., .085 μ H Choke and bead

L111	2405559P07 or 2405539P08	2-1/2 turns, airwound (2W) 1-1/2 turns, airwound (5W)
L112	2405559P11 or 2405559P21	4-1/2 turns, airwound (L), (M), (H, 2W) 4-1/2 turns, airwound (H, 5W)
L113, 114	2405559P01 or 2405559P02	6-1/2 turns, airwound (L), (M) 5-1/2 turns, airwound (H)
L115	2405559P01 or 2405559P02	6-1/2 turns, airwound (L), (M) 5-1/2 turns, airwound (H)
L116, 117	2482723H38	1.2 μ H Choke
L119, 120	2405559P01 or 2405559P02	6-1/2 turns, airwound (L), (M) 5-1/2 turns, airwound (H)
L201	2405452C70	190 μ H Choke
LS1	5005155Q03	TRANSDUCER
MK1	0105956P37	MICROPHONE ASSEMBLY:
P1	2805572P01	PLUG:
P2	2805572P01	Connector, Flex Top; 13-pin
P3	2805144Q01	Connector, Flex Top; 13-pin
P4	2805144Q01	Connector, Synthesizer; 7-pin
P5	2805433R02	Connector, Synthesizer; 7-pin
P6	2805247Q01	Connector, Front Cover
P7	-----	Connector, I-F
Q1	4805218N08	Not field replaceable, order Top Control Panel Assembly 0105951N41
Q2	4805452G08	TRANSISTOR: See Note II
Q3	4805218N09	NPN
Q101, 102	4805218N09	Dual Gate MOSFET; Type M52G08
Q103	4805474G37	NPN
Q104	4805452G06 or 4805474G33	NPN; Type M74G37 NPN; Type M52G06 (2W) NPN; Type M74G33 (5W)
R1	0660076A67	RESISTOR, Fixed: W \pm 5%; 1/10W unless stated
R2	0660076A87	5.6k
R3	0660076A59	39k
R6	0660076A49	2.7k
R7	0660076A73	1k
R9	0660076A45	10k
R10	0660076A56	680
R13	0660076A71	2k
R14	0660076A84	8.2k
R15	0660076A71	30k
R16	0660076A36 or 0660076A31 or 0660076A43	8.2k 300 (L) 20/25KHz 180 (M) 20/25KHz 560 (H) 20/25KHz
R17	0660076A25	100
R100	0660076A71	8.2k
R101	0660076A84	30k
R102	0660076A65 or 0660076A59	4.7k (L), (M), (H, 2W) 2.7k (H, 5W)
R103	0660076A69 or 0660076A68	6.8k (L), (M, 5W), (H, 5W) 6.2k (M, 2W), (H, 2W)
R104	0660076A80 or 0660076A84 or 0660076A79 or 0660076A82	20k (L, 2W) 30k (M, 2W) 18k (H, 2W) 24k (5W)
R105	0660076A25 or 0660076A26 or 0660076A32	100 (L), (M, 2W) 110 (M, 5W) 200 (H)
R106	0660076A75 or 0660076A67 or 0660076A73	12k (L) 5.6k (M, 2W), (H, 2W) 10k (M, 5W)
R108	0660076A65 or 0660076A17 or 0660076A25	4.7k (H, 5W) 47 (2W) 100 (L, 5W)
R109	0660076A23 or 0660076A17 or 0660076A07 or 0660076A09	82 (M, 5W), (H, 5W) 47 (L, 2W), (M, 2W), (H) 18 (L, 5W) 22 (M, 5W)
R111	0660076A46	750
R112	0660076A29 or -----	150 (5W Models) Not used on 2W Models
R127	0660076A29	150
R128	0660076A71	8.2k
R129	1805559S02	Pot., 50k
R130	0660076A87	39k
R131	0660076A36	300 (L, 2W Models only)
R140	1805100Q03	Pot., 5k

S1	-----	SWITCH: On/Off, Part of R140
S2	4005148Q02	2- & 8-channel radios
S3	or 4005265Q02	16-channel radios
S301	4005101Q01	Toggle, SPDT
S302	3905834K01	Snap Dome, Monitor
S303	3905834K01	Snap Dome, PTT
		Snap Dome, Monitor
		CIRCUIT MODULE:
		See Note I
U1	5102001J06	I-F
U103	5102001J07	I-F (12.5kHz only)
U104	5105822P51	Antenna Switch
	5105822P64	Antenna Selector (2W)
	or 5105729E93	Antenna Selector (5W)
U106	5105729E52	Ref. Oscillator
	5105729E72	Ref. Oscillator
		(12.5kHz only)
U201	5105822P61	VCO (L)
	or 5105822P60	VCO (M)
	or 5105822P59	VCO (H)
U202	5102001J03	Synthesizer
VR102	4805129M61	DIODE: See Note I
VR301	4805129M42	Zener, 18V
		Zener, 5.6V
NONREFERENCED ITEMS		
	0200007007	NUT, Hex; 8-32 X 1/4" X 3/32" (for Q104, 5W Models)
	0300136771	SCREW, Phillips; 2-56 X 3/16" (for Q104 heatsink)
	0705196A04	BOOT, for FL1, FL2
	0705766R01	SUPPORT, Rubber
	1400861196	INSULATOR, for Q103
	1405496R01	INSULATOR (I-F)
	2605116S01	SHIELD, P.A. Output
	2605494R01	SHIELD, I-F Module
	2605524P01	CAN, for L11, L12
	2605524P03	CAN, for L111 thru L115, L119, L120, and L108 (5W Models)
	2605532P01	HEAT SINK, for Q104 (5W Models)
	2605578P01	HEAT SINK, for Q104 (2W Models)
	2605696R01	SHIELD, Antenna Switch
	2605820D07	CAN, for L1, L2
	2683379H01	HEAT SINK, for Q103
	3905130N01	CONTACT STRIP
	3905509R02	CONTACT
	7505295B07	PAD, for FL1, FL2
	7505695R01	CUSHION, for U106
	8405589P03	PC BOARD (2W)
	8405591P03	PC BOARD (5W)

NOTES:

- I. For optimum performance, order replacement diodes, transistors, and circuit modules by Motorola part number only.
- II. When ordering crystal units, specify carrier frequency, crystal frequency, crystal type number, and Motorola part number.

* Not field replaceable, order microphone flex assembly 0105956P37.

REFERENCE SYMBOL	MOTOROLA PART NO.	DESCRIPTION
		CAPACITOR, Fixed: pF ±5% 50V unless stated
C400	2113741B33	3300
C401	2360562A07	0.47uF; 25V
C403	2160521G37	0.1uF +80 - 20%
C404	2360562A28	4.7uF; 10V
C405, 406	2111032B13	0.1uF +80 - 20%
C408	2113741A37	4700 ± 10%
C410	2111032B13	0.1uF +80-20%
C415	2360562A43	10uF; 16V
C416	2160521G37	0.1uF +80-20%
C420	2360562A13	1uF; 16V
C421	2113740A29	10
C422	2113740B29	15
C423	2113740A55	100
C424	2160521G37	0.1uF +80 - 20%
C426	2113740A55	100
C431	2160521G37	0.1uF +80 - 20%
C438	2113740A67	330
C442, 443, 444	2360562A13	1uF; 16V
C445	2360562A35	10uF; 25V
C446	2113741A39	5600
C447	2113741A31	2700
C448	2113741A45	.01uF
C449	2111032B13	0.1uF +80 - 20%
C452	2360562A28	4.7uF; 10V
C453	2360562A43	10uF; 16V
C456 thru 460	2113740A59	150
C466, 467	2113740A53	82
C470	2113741A45	.01uF
C471	2360562A13	1.0uF; 16V
C472	2113740B47	82
C481	2360562A43	10uF; 16V
C483, 484	2113741A21	1000
C485	2113740B47	82
C486	2360562A13	1uF; 16V
C488, 489	2160521G37	0.1uF + 80 - 20%
C490	2113741A45	.01uF
C491, 492	2113741A53	.022uF
C493, 494	2160521G37	0.1uF + 80 - 20%
C497	2113741A53	.022uF
C498	2113741A37	.0047uF
C499	2113741A45	.01uF
C801	2113741B33	3300
C802	2111032B13	0.1uF +80 - 20%
C803	2160520P08	2000
C804	2113740B61	330
C805	2113741B45	1000
C806	2111032B13	0.1uF +80 - 20%
CR403, 404, 405	4805494Q04	DIODE: See Note Silicon
CR409, 410, 411	4805494Q04	Silicon
J1	0905573P02	JACK: Connector, Controller Flex Top; 13-pin
J2	0905573P02	Connector, Controller Flex Top; 13-pin
J3	0905577P01	Connector, Synthesizer; 7-pin
J4	0905577P01	Connector, Synthesizer; 7-pin
J5	0905504R01	Connector, 10-pin
J6	0105959M27	Header Assembly, 13-pin
J7	-----	Not field replaceable, order Volume Pot. Flex 0105956M66
L400 thru 409	2462575A01	COIL, RF: unless stated 0.39uH Choke
L410	2460590A02	150uH Choke
L411 thru 415	2462575A01	0.39uH Choke
Q400	4805128M94	TRANSISTOR: See Note II PNP
Q401	4805128M12	NPN
Q402, 403, 404	4805128M94	PNP
Q405, 406	4805128M12	NPN
Q407	4805128M94	PNP
Q410	4805128M10	PNP
Q412	4805128M94	PNP
Q413	4805128M12	NPN
Q414	4805128M94	PNP

Q415, 416, 420	4805128M12	NPN
		RESISTOR, Fixed: Ω ± 10%; 1/8W unless stated
R400	0611077B23	100k
R401, 402	0611077A98	10k
R403	0611077A92	5.6k
R404	0611077A98	10k
R405	0660076K49	10 Meg
R406, 407, 408	0611077B23	100k
R409	0611077A72	820
R410	0611077A84	2.7k
R411	0611077A98	10k
R412, 413	0611077B23	100k
R414	0611077B16	51k
R417	0611077A81	2k
R419	0660076A56	2k ±5%; 1/10W
R421	0611077A66	470
R422	0611077A76	1.2k
R423	0611077B09	27k
R424	0611077A78	1.5k
R425	0660076F01	100k ± 1%
R426	0660076E84	30k ± 1%; 1/10W
R427	0660076A94	75k ±5%; 1/10W
R428	0660076B05	150k ±5%
R429	0660076B01	100k ±5%
R430	0611077A98	10k
R434	0611077A66	470
R438	0611077B23	100k
R439	0611077A98	10k
R440	0660076A73	10k ±5%; 1/10W
R441	0660076B25	1 Meg ±5%; 1/10W
R443	0611077B23	100k
R446	0611077A50	100
R447	0611024J08	158k ± 1%
R448	0611024H84	90.9k ± 1%
R449	0611077A26	10
R450	0611077A98	10k
R451	0611077B15	47k
R452	0611077A79	1.6k
R453, 454	0611077A74	1k
R462	0660076A73	10k ±5%; 1/10W
R466	0611077A98	10k
R467	0611077A84	2.7k
R470	0611077A50	100
R472	0611077A50	100
R480, 461	0611077B23	100k
R481	0611077A98	10k
R482	0611024J09	162k ±1%
R483	0611024H88	100k ±1%
R484	0611024H09	15k ±1%
R485	0660076E90	51k ±1%; 1/10W
R486, 487	0611077A82	2.2k
R801, 802	0611024J73	750k
R803	0611024J14	182k
R804	0611077B25	120k
R805	0611077B11	33k
R806, 807	0611077A96	8.2k
R808	0611077B47	1 Meg
U401	0105958P12	CIRCUIT MODULE: See Note I Microcomputer
U402	0105958N07	EEPROM
U403	0105957N87	Hex Gate
U405	0105951Q59	Audio Filter
U406	0105958P03	Audio PA
U407	5160880B01	5V Regulator, CMOS
U801	0105957N83	Quad Op-Amp
VR401, 402	4880140L09	DIODE: See Note I Zener, 6.2V
VR407-409	4880140L09	Zener, 6.2V
Y401	4805664G33	CRYSTAL: See Note II 3.6864MHz

NOTES:

- I. For optimum performance, order replacement diodes, transistors, and circuit modules by Motorola part number only.
- II. When ordering crystal units, specify carrier frequency, crystal frequency, crystal type number, and Motorola part number.