

PERSONAL RADIOTELEPHONE

CQP466x

400 - 470 MHz

**Storno**

PERSONAL RADIOTELEPHONE

CQP466x

400 - 470 MHz

Date: 09.83

Edition: 1.

Publication no: 8311.4660-00

## STORNOPHONE 4000

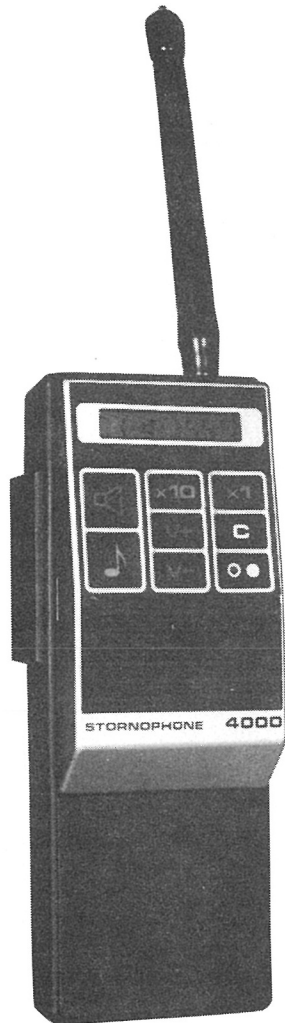

Local controlled personal radio for simplex or semi duplex operation with all necessary indicators located in a liquid crystal display.

The construction of the electronic keyboard is using the most modern laminated film technology.

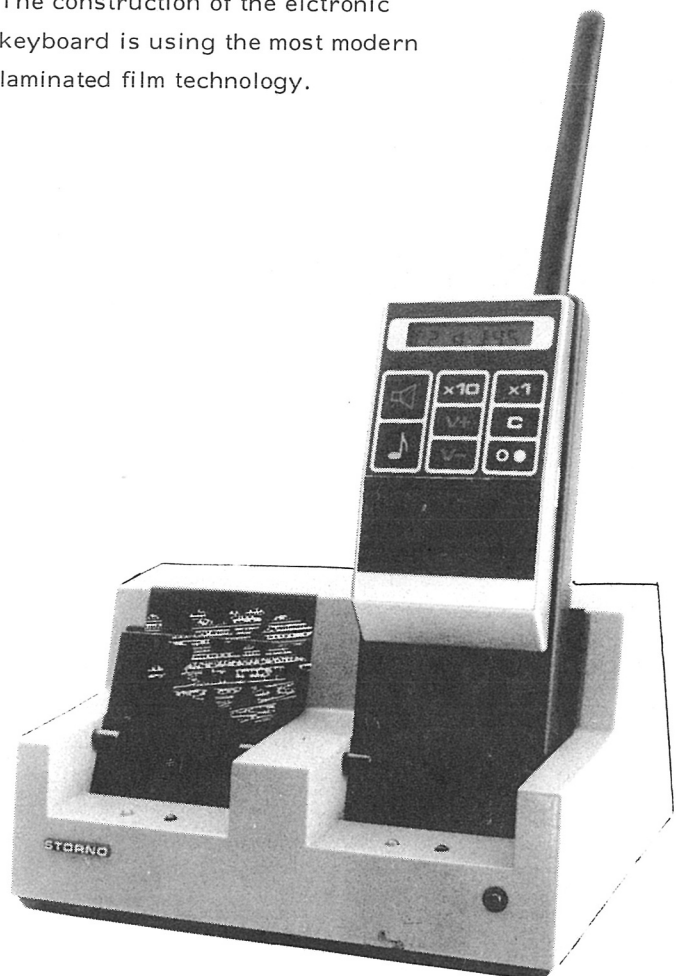

The fully automatic charger CU4001 provides charging of either the battery alone or when inserted in the radio.



## GENERAL SPECIFICATIONS

## CQP4000

Guaranted performance specifications unless otherwise noted.

TYPE CQP		4332	4333	4334	4112	4113	4114	4552	4662	4663	4664	
Freq. & splits	MHz	66-78	74-88		146-174			350-380 370-400	400-440 430-470			
Channel spacing	kHz	25	20	12.5	25	20	12.5	25	25	20	12.5	
No. of channels		1 or 2										
Service		Simplex or semi duplex										
Frequency Stability	ppm	± 5 or ± 10						± 5	± 5		± 3	
Operating temperature	deg. C	-25 to +60										
Antenna impedance	ohm	50										
Battery	V/ mAh	7.2 V Nominal		450 mAh			6 ni-cad cells 6.1 V to 8.6 V at extreme conditions					
Cur. drain: OFF RX (stby) RX (.5 WAF) TX (2 W)	mA	CQP411x/-433x : 30 / 35 : CQP466x 155						Additional standby currents: CG4001 : 1.3 CG4002 : 1.0 CG4003 : 1.3 TQ4001 : 1.5 TQ4002 - TQ4007 : 2.0				
Operator control		 LS ON/OFF and squelch cancel  Tone transmission X10 Tone select; controls left tone digit on LCD X1 Tone select; controls right tone digit on LCD V+ Volume "UP" V- Volume "DOWN" C Channel select  ON/OFF and LCD light										
Display		Channel, TX, LS, Call, Tone codes										
Dimensions	mm	Hight= 192,7		Width= 72,5		Depth= 26,5/42,5		(with 450 mA/h Batt. (with 750 mA/h Batt.				
Weight	kg.	0.6 with 450 mA/h Batt., 0.66 with 750 mA/h Batt..										

The equipment described above meets or exceeds all applicable CEPT, FTZ, Swiss and Swedish specifications.

## RECEIVER SPECIFICATIONS

## CQP4000

Guaranteed performance specifications unless otherwise noted.

TYPE CQP		4332	4333	4334	4112	4113	4114	4552	4662	4663	4664	
Sensitivity 20 dB SINAD (CEPT)	uV EMF	0.75		1	0.75		1	1			1.5	
RF bandw.	MHz	2.5 (No degradation w. centertuning)										
AF outp. pwr.	W	0.5 EIA, 0.25 CEPT method.										
Aud. bandw.	Hz	300- 3000	300 - 3000	300- 2550	300- 3000	300 - 3000	300- 2550	300- 3000	300- 3000	300 - 3000	300- 2550	
Aud. resp.		-6 dB/oct. phase modulation characteristics.										
Tolerance	dB	+1 -3	+1 -3	+1 -3	+1 -3	+1 -3	+1 -3	+1 -3	+1 -3	+1 -3	+1 -3	
Hum & noise	dB	-45 (CEPT, weighted)										
Adj. ch. sel.	dB	-70		-60	-70		60	70			-60	
Cond. spur.	dBm	-57										
Rad. spurious	nW	2 (-57 dBm to resonant substitution dipole)										
AF distort.	%	2 EIA, 10 CEPT method										
Blocking	dB/ uV	90										
Intermodul.	dB	CEPT= 70, Sweden= 70, FTZ= 66 & 80										
Spurious rej.	dB	-70 (CEPT method)										
Co-chan. rej.	dB	8										
Sq. sens.	dB	5 - 6 (dB SINAD at line Output)										
Squelch tail	mS	5 (EIA)										
RX att. time	mS	50 (EIA)										
Recovery tm.	mS	75						100				
Group delay	uS	Less than 50										

<sup>+</sup> Tolerance on response from 400 to 2700 Hz is +1, -1.5 dB.  
The equipment described above meets or exceeds all applicable  
CEPT, FTZ, Swiss and Swedish specifications.

## TRANSMITTER SPECIFICATIONS

## CQP4000

Guaranteed performance specifications unless otherwise noted.

TYPE CQP		4332	4333	4334	4112	4113	4114	4552	4662	4663	4664	
RF outp. pwr.	W	0.1W or 2W -adjustable to 1W :								± 1.5 dB for -10/+40 deg. C + 2/3 dB for -25/+55 deg. C		
Duty cycle	%	20% at 25 deg. C ambient : TX= 1 mn, standby/RX= 4 mn										
RF bandwidth	MHz	2.5 (No degradation)										
Mod. BW	Hz	300- 3000	300 - 3000	300- 2550	300- 3000	300 - 3000	300- 2550	300- 3000	300- 3000	300 - 3000	300- 2550	
Mod. resp.		+6 dB/oct. phase modulation characteristics at 6000 Hz att: ≥6 dB rel. to 1 kHz value.										
Tolerance	dB	+1 -3	+1 -3	+1 -3		+1 -3		+1 -3		+1 -3	+1 -3	
Max. dev.	kHz	5	4	2.5	5	4	2.5	5	5	4	2.5	
Resid. mod.	dB	-40 (Weighted, ref. to 60% dev.)										
Adjacent Chan. power	dB/C	70		60	70	60		70		60		
Cond. spur.	dBm	-37										
Radia. spur.	nW	200 (-37 dBm to resonant substition dipole)										
Attack time	mS	30						50				
Group delay	uS	Less than 50										
TX stability		10:1 VSWR, all phase angles										
Audio sensitivity	mV	10 mV ±3 dB										
Aud. dist.	%	5										

+ Tolerance of response from 400 to 2700 Hz is +1, -1.5 dB.  
The equipment described above meets or exceeds all applicable  
CEPT, FTZ, Swiss and Swedish specifications.

## GENERAL DESCRIPTION

### CQP4000

STORNOPHONE 4000 is a personal radiotelephone with transmitter, receiver, controls and display, loudspeaker, microphone and battery. Although being handheld and compact in size the radio can be programmed with two channels and optionally, be equipped with sequential tone encoder/decoder, CTCSS encoder, or CTCSS encoder/decoder.

The mechanical construction of the radio is a screened enclosure in the form of a cast chassis and a metalized plastic front as lid.

A moulded plastic house is attached to the chassis to provide mechanical protection and hold the battery. All controls and indicators are integrated in a keypad/display field on the radio front except for the transmit button which is on the left side of the radio.

The electrical circuitry of the radio is built on printed wiring boards: an RF-board containing the transmitter and receiver, a control logic board and, optionally, a thick film tone module.

The RF-board comprises the frequency synthesizer, the transmitter exciter and power amplifier, the receiver RF circuits and IF-circuits, the voltage regulator, and is available in different versions according to frequency band and channel spacing.

The control logic board (CL) comprises the receiver AF amplifier, the transmitter modulation processor, the microcontroller and the display.

The tone module is a thick-film add-on module designed to be plugged into a socket on the CL-board.

#### ANTENNAS

The CQP4000 is designed for a 50-ohm antenna which is screwed onto the top of the radio.

The following types are available:

- a resonant helical antenna
- a wide band conductive rubber antenna

#### BATTERIES

The battery is designed to snap into a compartment at the bottom of the radio and is a selfcontained nickel-cadmium (Ni-Cd) pack.

Two battery packs are available:

- a 450 mA battery
- a 750 mA battery

#### CARRYING DEVICES

The following devices are available for carrying the radio:

- a carrying kit consisting of a strap and eyelets to be inserted in the plastic housing.
- a carrying case made of black leather with a display window and flaps for access to the controls and the battery.

#### BATTERY TESTER

A battery tester is available for checking the charge condition of batteries. A button on the tester loads the battery and the charge condition is read on a meter scale.

#### OPERATING INSTRUCTIONS

All buttons, except the transmit button, will when pressed respond with an attention tone, approx. 40 ms long, to give the operator an indication of a depressed button.

## ON/OFF/DISPLAY LIGHT

When the battery is inserted the radio is turned on by pressing the ON/OFF button. When the radio turns on the display light will be on for 4.5 seconds and the light timer will be reset each time a button is pressed. The radio will be on channel 1 and variable tone digits, if used, set to 00. For sets with sequential tone receiver the loudspeaker will be off.

If the tone receiver is not fitted the loudspeaker is always on and the call indicator is not used.

The display light is turned on by pressing the ON/OFF button once.

The radio can only be turned off while the display light is on. To turn off press the ON/OFF button to light the display if not already on and then again press the ON/OFF button.

Before the control logic turns the radio off a high pitch tone is sounded for 1 second the volume being independent of the present volume setting.

When the battery is discharged and reach a certain voltage, the radio emits an acoustic alarm tone to inform the operator that the battery has to be replaced. The alarm tone is similar to that emitted when turning the radio off and if the operator does not turn the radio off the control logic will automatically turn off.

The battery condition is monitored only when the radio is in receive mode.

## CHANNEL SELECTION

When turned on the radio will be set to channel 1. To select channel 2 press the channel select button, C, which alternately selects channel 1 and 2.

The selected channel will be displayed as C1 or C2.

Channel selection can only take place while in receive mode.

## VOLUME SETTING

The loudspeaker volume can be adjusted in steps. There are 8 levels and when the radio is turned on the volume is automatically set to medium. To increase the volume press V+ and to lower the volume press V-. When the higher or lower limit is reached the volume can not be further adjusted until the opposite button is pressed. Each time a volume button is pressed the radio emits a short attention tone.

## LOUDSPEAKER ON/OFF (MONITOR)

This button and its display symbol is used with sequential tone option only.

With the sequential tone receiver option the loudspeaker is off when the radio is turned on. When the loudspeaker button is pressed the loudspeaker is turned on and the call indicator displayed. The loudspeaker is automatically turned on when a call is received or when the transmitter is activated.

## SQUELCH CANCEL

(with sequential tone receiver option)

When the loudspeaker is on the squelch function can be cancelled by keeping the loudspeaker on/off button depressed. If no signal is being received noise will be heard in the loudspeaker.

## SQUELCH CANCEL

(without sequential tone receiver option)

The squelch function is cancelled by pressing the loudspeaker on/off button.

## TRANSMITTING

Before a call can be transmitted the channel must be free. Any attempt to transmit when



the loudspeaker is off and the channel is busy will result in an alarm tone in the loudspeaker as long as the transmit button is depressed.

For radios with sequential tone transmit option a call is initiated by pressing the transmit (PTT) button. A tone call is then transmitted and the loudspeaker automatically turned on. When the call is answered the transmit button is used for conversation. If the channel is busy the call is not transmitted.

For radios with sequential tone receive option turn the loudspeaker on and press the transmit button when the channel is free.

For radios without tone option wait until the channel is free. Then press the transmit button and speak into the microphone with normal voice.

The transmit indicator will be displayed while transmitting and all button functions will be inhibited.

#### TONE CALL SWITCHING

(With sequential tone transmit option only)

The two tone call select buttons, X10 and X1, are used to select up to 100 different tone calls. The basic tone call format and the po-

sition of the selectable tones in the format are part of the personality data programmed into a Programmable Read Only Memory (PROM). Two digits are displayed to show the selected tone call. The X10 and X1 buttons are used to step the digit until the wanted number is displayed.

#### TONE CALL TRANSMISSION

A sequential tone call can be transmitted using the transmit button when the loudspeaker is off, refer to transmitting.

If the loudspeaker is on a tone call is transmitted by pressing the tone button. During the tone transmission the keyboard is inhibited.

#### TONE CALL RECEPTION

When a tone call is received the loudspeaker is automatically turned on, the call indicator displayed and an alarm tone sounded for approx. 1 sec. The call indicator is turned off when the transmit button or any other key is pressed.

If the acknowledge facility is present the acknowledge signal is automatically transmitted.

If group call facility is present a group call will automatically turn the loudspeaker on.

## MECHANICAL DESCRIPTION

### STORNOPHONE 4000

#### CHASSIS BOX

The chassis box is a tin plated zinc casting provided with an antenna socket and a sealing gasket for transmit button which activates a microswitch on the control logic board. The combined battery/test connector is attached to the chassis and potted for weather protection. Inside the bottom is a plate with fingers pressing against the solder side of the RF-board and thus obtains the necessary ground connections.

The RF and CL boards are kept in position with 4 screws which attach the chassis box

to the front part. In the chassis bottom are two threaded inserts for attaching the rear part of the plastic cover.

The plastic cover has a battery compartment which will accept two types of batteries. The battery snaps into position by means of a moulded contour on the inner side of the compartment wall. The battery is released by pressing through a hole in the rear wall.

An 18-position battery and test connector is placed inside the battery compartment. 5 of the connector pins are used for connection to the battery. The others are used for automatic or manual testing.

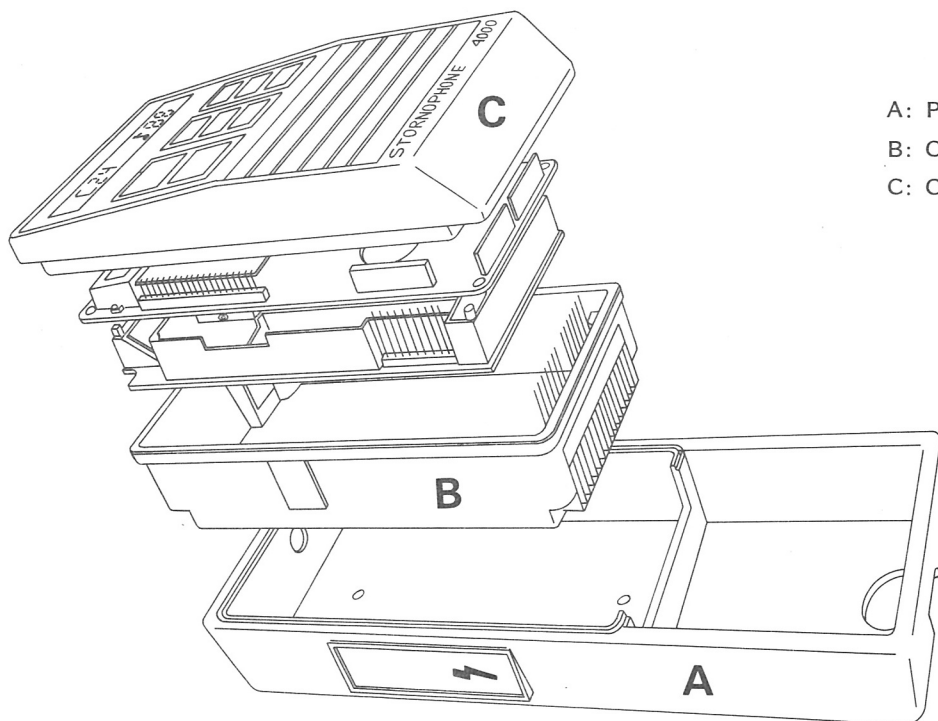

A: Plastic cover  
 B: Chassis box  
 C: Control Panel Front

## CIRCUIT DESCRIPTION

### CQP4110

#### RECEIVER

The receiver is a dual conversion superheterodyne receiver with a first IF of 21.4 MHz and second IF of 455 kHz. All receiver circuitry except the AF amplifier is placed on the RF board.

##### Receiver front-end

The receiver front-end consist of a 2-resonator input filter, a common base bipolar transistor RF amplifier, a 2 resonator intermediate filter and a junction FET 1st mixer. The drain of the FET is connected to first IF resonant circuit which is used to match the crystal filter. Source injection is used.

##### IF and demodulator

The first IF frequency is 21.4 MHz. The output from the two stage monolithic crystal filter is fed to a dual gate MOSFET amplifier which overcomes the noise figure of the following stages while providing a constant load to the crystal filter with varying signal levels.

Second mixer is an IC including crystal controlled self oscillating active mixer, 455 kHz limiter amplifier, quadrature discriminator and squelch gate.

Selectivity of the 455 kHz IF amplifier is formed by a ceramic filter fed from the mixer stage.

The integrated circuit also contains the quadrature type FM-detector which produces the audio line signal.

##### Squelch

The squelch circuit is, with exception of the schmitt-trigger, build as a separate thick-film module which is soldered into the RF-board.

The AF-signal from the quadrature detector is fed to an active high-pass filter, where noise over 7 kHz is extracted. Via the squelch adjust potentiometer the signal is fed to an amplifier to obtain the right level for the detector. The output of the detector is connected to the schmitt-trigger which is part of the IF-IC. This gives the necessary hysteresis and well-defined output signal.

The squelch potentiometer is adjusted for 10-12 dB S/N squelch sensitivity.

##### Audio power amplifier

The audio power output amplifier on the CL board is a standard monolithic IC capable of driving the loudspeaker at the desired power level (500 mW in 8 ohms). The AF-line signal is either fed through the channel guard reject filter or applied directly to the volume control.

The deemphasis (6 dB per octave) and a 2nd order high pass filter which cut off at 300 Hz is included in the feedback circuitry around the audio amplifier. The amplifier is muted by switching the supply voltage off by means of a switch-transistor, controlled by the control logic.

The gain is approximately 30 dB at 1 kHz corresponding to 6 dB overdrive at rated input and full volume setting.

#### TRANSMITTER

The transmitter consists of an exciter and a power amplifier assembled on the RF board along with receiver and synthesizer.

The synthesizer drives the exciter directly. The exciter contains wideband stages and delivers output to the power amplifier.

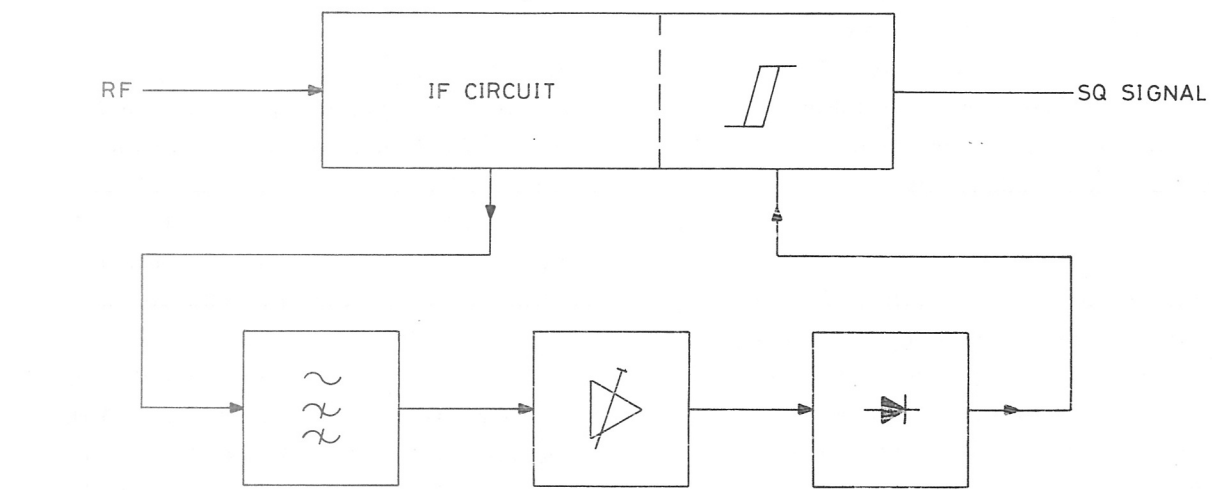
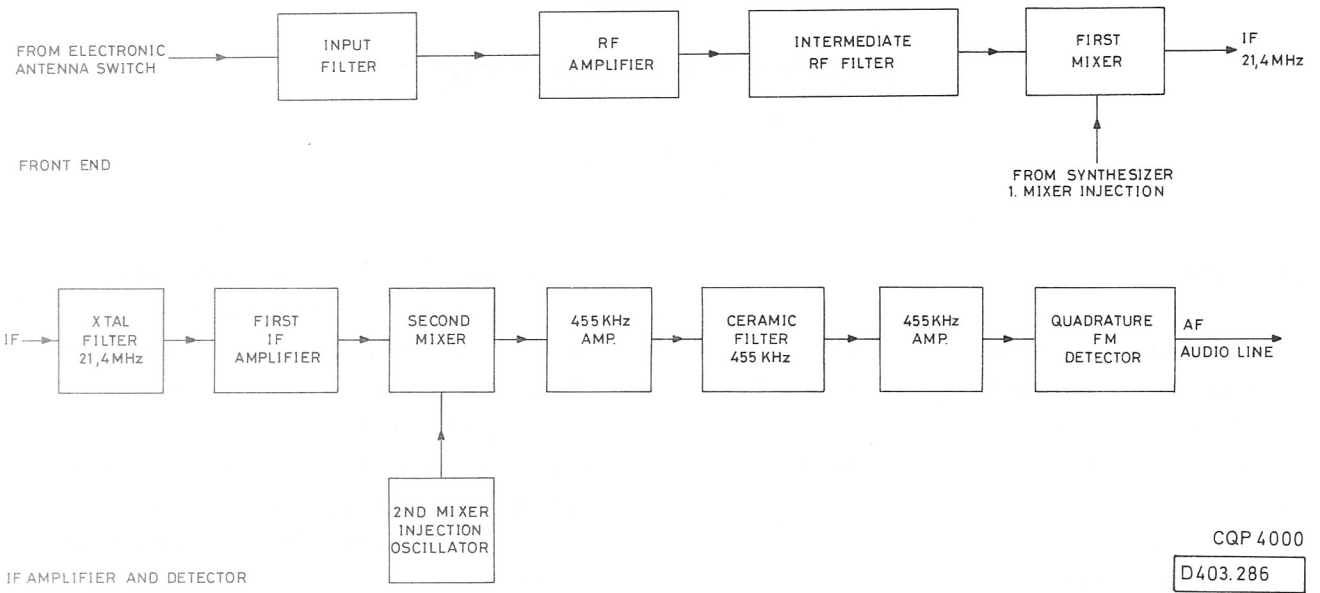

SQUELCH CIRCUIT

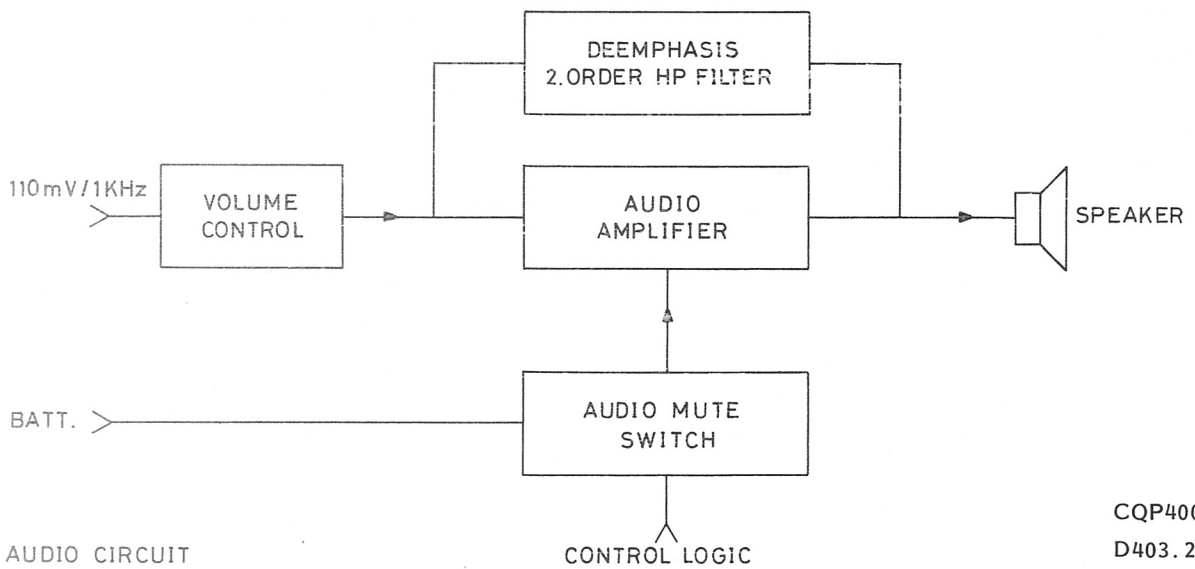

AUDIO CIRCUIT

CQP4000  
D403.289

All stages, including the frequency synthesizer VCO, operate at carrier frequency.

The power amplifier includes the output stage, a low-pass filter, and circuitry for adjustment of the operating power level.

The power amplifier is connected to the low pass filter via a diode antenna switch.

#### Exciter

The exciter takes the VCO signal, 1 mW, and amplifies it to 0.5 Watt. It consists of three wide band stages which covers the whole band. Maximum frequency spread of transmitter channels is limited by the synthesizer.

#### PA

The PA consists of a single broadband amplifier.

The antenna is matched to the power amplifier by tuning the antenna or by using a wide band antenna.

A power control circuit keeps the RF output relatively constant with variations in temperature and voltage. The output power level can be set with a potentiometer over a 2:1 range.

The transmitter can operate with intermittent duty cycle (1 minute transmit, 4 minute standby) to any load VSWR at 25 dgr. C and battery supply voltage of 7.2 V.

#### TX audio processor

TX audio processing is performed by a microphone amplifier, a limiter and a roll off filter. The microphone preamplifier consists of an operational amplifier and a gain setting network also providing the preemphasis.

The limiter is an amplifier built from discrete components. The modulation limiting is obtained by overdriving the amplifier. The coupling capacitor from the microphone amplifier to the limiter is designed to roll off at frequencies below 300 Hz.

A 3rd order active lowpass filter consisting of an operational amplifier and a feedback net-

work followed by a 1st order *passive* LP filter performs the sufficient roll off at frequencies above 3 kHz. For 12.5 kHz and Sweden the roll off frequency is reduced to 2.55 kHz by cutting one resistor.

5-tone sequential encode signal is fed to the limiter and channel guard signal to the active filter.

#### Warning

The transmitter PA-transistors contain Beryllium which can cause poisoning when absorbed by the human body.

Dissection of these transistors may be hazardous to health.

#### SYNTHESIZER

All synthesizer circuitry is placed on the RF which also includes receiver and transmitter circuits.

Frequency information is presented to the synthesizer as 8 words of 4 bit data which are stored in the PROM and placed together with the processing circuitry on the control board. Channeling information is loaded to the synthesizer and latched under processor command when the unit is turned on, the channel changed or the transmit-receive key activated.

The basic synthesizer is a single loop system equipped with a low power dual modulus prescaler.

The frequency is controlled by a single crystal which is the same for all channels across the band - except for isolated cases of self quieting. In those cases an alternate reference crystal will be used.

Loop noise bandwidth is chosen around 70 Hz to permit modulation bandwidth from 70 to 3000 Hz so operation with analog channel guard (CTCSS) is possible.

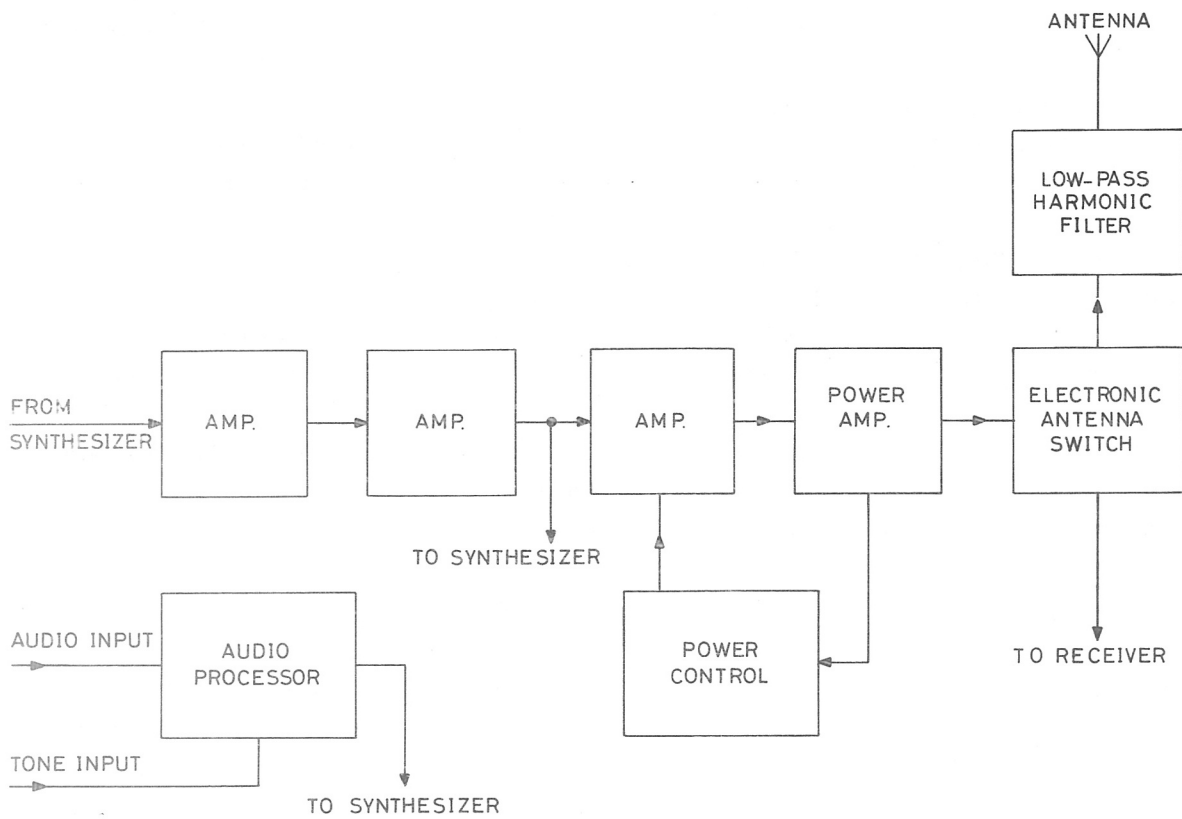

TRANSMITTER BLOCK DIAGRAM

CQP4000  
D403.287

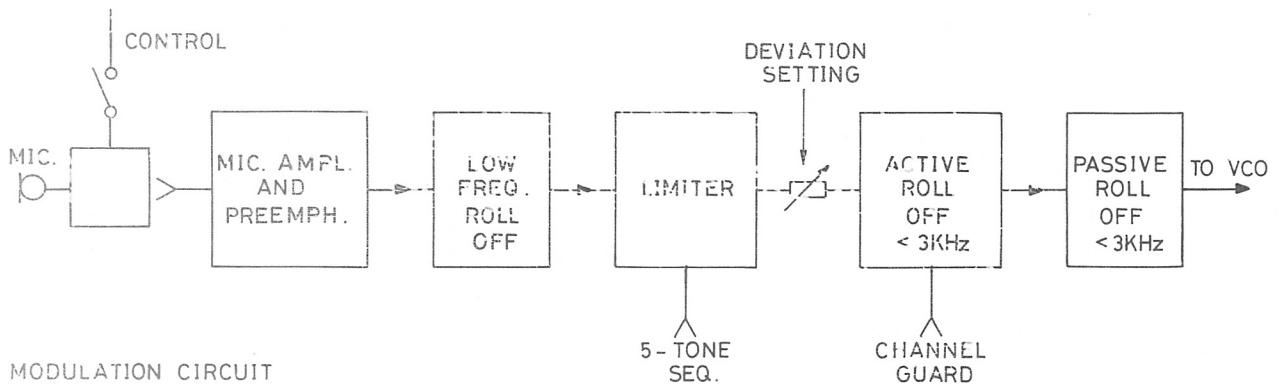

MODULATION CIRCUIT

CQP4000  
D 403.289

To reduce DC power consumption, the synthesizer is equipped with a power saving system which is active when the radio is in standby condition.

The power saving circuitry is not operative during transmit, receive or out of lock conditions.

The synthesizer is capable of simplex or semi-duplex operation with possibility of non constant RX-TX spacing.

An out of lock circuit inhibits the transmitter when synthesizer is out of lock.

#### Synthesizer VCO

Separate voltage controlled oscillators (VCO) are used for transmitter and receiver.

The frequency of each VCO can be preset for any frequency in the band by a variable capacitor. Final frequency adjustment is made by the phase detector output which is connected to the VCO varicaps via a passive loop integrating filter and a charge pump.

The transmitter VCO has an additional varicap for modulation and a circuitry to obtain constant modulation sensitivity across the tuning range.

#### VCO buffers

The output from transmitter VCO is fed to the exciter. The first two stages of the exciter are used as buffer for the synthesizer.

The output from the receiver VCO is buffered by an injection amplifier before it is fed to the first RF mixer and the prescaler.

#### Prescaler, dual modulus

The prescaler is dividers with low power consumption (4 to 7 mA) and is used to scale down the relatively high VCO frequency into the operating range of the C-MOS circuitry.

#### Frequency synthesizer

The frequency synthesizer consists of:  
Reference divider (divide by 3 to 4095)  
variable N divider (divide by 3 to 1023),  
variable A divider (swallow by 3 to 127),  
8-each 4 bit-latches, phase-frequency and lock detector which are contained in a single integrated circuit.

Frequency information which comes from the control board sets the internal latches and subsequently the counter ratios to generate the appropriate frequency.

The phase frequency detector's operating frequency depends on channel spacing of equipment.

#### Current save switch and passive loop integrator

The charge pump receives pump up and pump down commands from the phase detector and current save commands from the control board. A current save command from the control board disconnects the loop integrator from the phase detector.

The current save switch is only operative during standby with a 12:1 duty cycle, i.e. with 140 ms on, 1.6 second OFF.

#### Reference oscillator

The crystal controlled reference oscillator determines the total frequency stability of the radio.

#### POWER SUPPLY

The 7.2 V battery voltage is distributed for different purposes through a 5 A fuse:

- Directly to the RF power amplifier.
- To the audio output amplifier through a switch transistor.

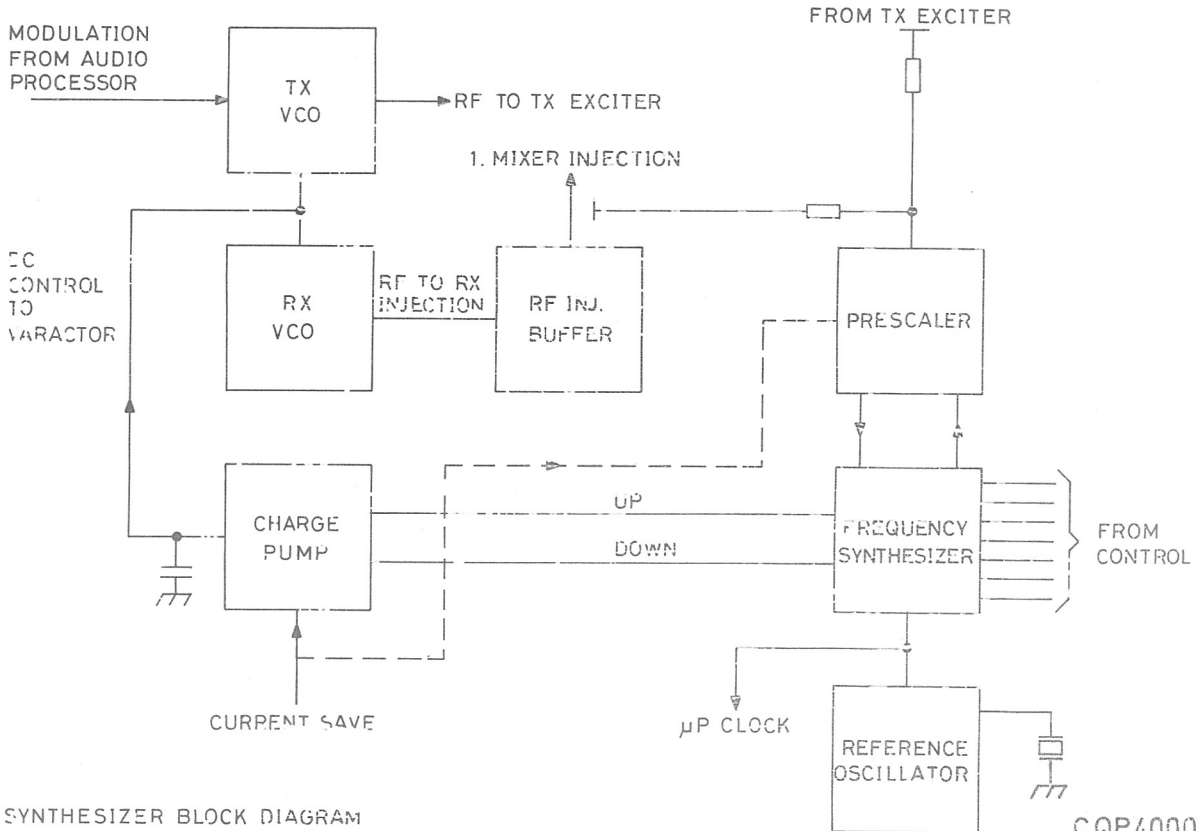

SYNTHESIZER BLOCK DIAGRAM

CQP4000  
D403.287

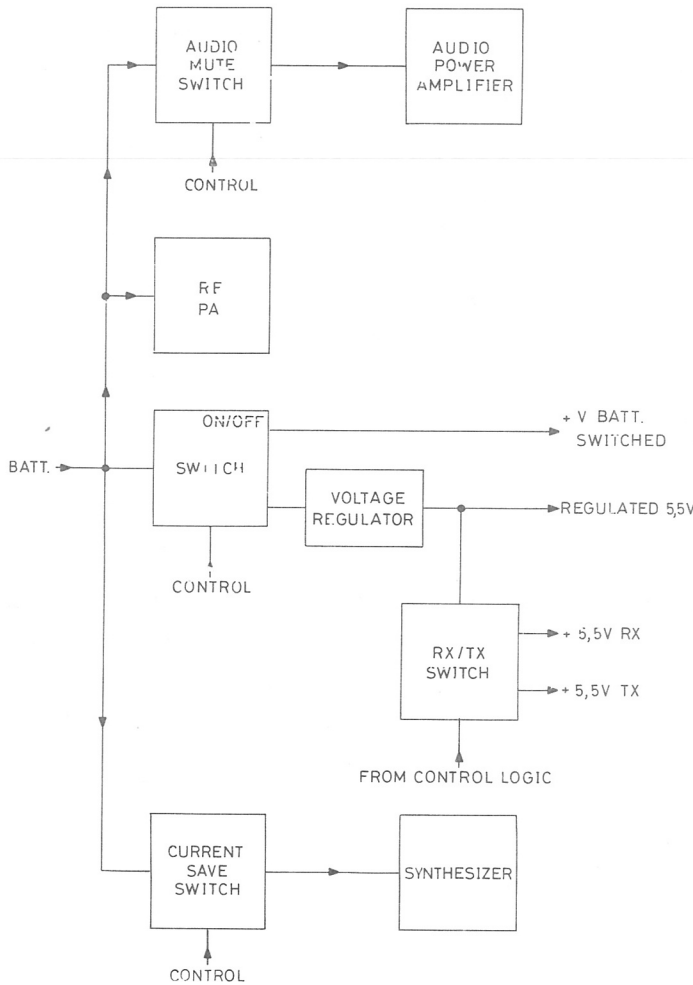

VOLTAGE SUPPLY DISTRIBUTION SYSTEM

CQP4000  
D403.288



- Through the on/off switch-transistor to the IF/squelch circuits and to the 5.5 V voltage regulator.
- To the personality PROM through a separate regulator.
- To the LED's for the LCD display-back-light.

Operating Hours, nominal

Output	Transmit	Receive	Standby	Toneeq.	Operation
2 Watt	5%	5%	90%	YES	6.3 Hours
2 Watt	2%	5%	93%	YES	9.8 Hours
2 Watt	5%	25%	70%	NO	5.3 Hours
2 Watt	2%	25%	73%	NO	7.6 Hours

Voltage regulator

A 5.5 V stabilized voltage regulator is designed around an adjustable shunt regulator IC, with low drop-out voltage, high temperature stability and short circuit protection. Regulated 5.5 V is continuously applied to the IF-squelch - and synthesizer circuits, to the RX/TX switch-circuit controlled by the control logic, and through a current save switch to the prescaler in the RF synthesizer.

The RX/TX switching is performed - where possible - by switching only the bias currents to the involved circuits.

**CONTROL LOGIC**

All control functions are concentrated around the microcontroller on a separate control board to which the tone-option is connected as a plug in module (thickfilm hybrid).

Microcontroller:

The central part of the control logic is a 4-bit microcontroller with 1 K x 8 bit mask programmed memory (ROM) and 64 x 4 bit data memory (RAM). All timing and logical functions are processed by means of the internal software program.

Input/output:

The microcontroller has one 8-bit and one 4-bit bidirectional port, one 4-bit input port and one 4-bit output port. To expand the output capacity, the serial output port of the microcontroller is connected to two "serial in-parallel out" circuits.

Personality PROM:

All data related to the individual radio are programmed into a 256 x 4 bipolar PROM identified as the "personality PROM", i.e. RF-frequency codes, tone-frequency and telegram specification, and option information. The PROM-data are handled by the microcontroller software program.

Display drivers

Three IC's are used to latch the data and drive the LCD-display. An approximately 40 Hz clock for the display is generated by two gates.

Display

The LCD-display contains 3 seven-segment digits and 5 separate symbols. The display is illuminated by 4 green LED's.

Keypad

The keypad is organized in a 2 x 4 matrix (one separate line for on/off) and contains all the operator controls except the PTT.

Battery voltage test

A voltage comparator gives a logic signal to the microcontroller when the battery-voltage drops below the specified limit.

Attention tone generator

Two gates are generating an approximately 1 kHz attention tone signal.

Software

The software serves the purpose of functionally linking the different hardware modules together.

The microcontroller gets its inputs from the keyboard, the PTT-button, the tone-detect outputs, the FS-lock detect and the squelch. The information is decoded by means of the software to decide the actions to be executed in order to accomplish the proper output functions.

The software program consists of a main loop and some subroutines. Apart from the initialization block, each of the blocks in the main loop will be executed continuously. The actual status of the system decides how much of each program block that has to be executed. From the main loop it is possible to call the subroutines which perform the functions required in several of the main program blocks.

The allocation of program memory bytes for different purposes is indicated on the block diagram.

Personality PROM

The channel frequency codes, the system and tone definition and the tone frequency table are programmed into a bipolar PROM, 256 x 4 bits.

To reduce power consumption, the PROM is only turned on when addressed by the microcontroller.

## CONTROL LOGIC FUNCTIONS

RF/AF control

The main portion of the general control functions in the radio is performed by the microcontroller and its peripheral circuits situated on the control board.

Volume control

The volume control is a digital/binary controlled attenuator circuit. The level is adjustable in 7 steps with approximately 5 dB per step. This function is realized by a resistive attenuator and an analog switch controlled by 3 bits coming from the microcontroller. The 4th bit breaks the line signal during the attention tone.

Audio amplifier

The audio output amplifier is in stand by mode turned off by a switch transistor in the supply line. The control logic will decide whether the audio amplifier is on or off, depending on the input from the receiver squelch and, if a tone option is installed, the input from the tone detector.

The audio amplifier is also turned on, either every time a button is pressed or when a selective call is received, to amplify the attention tone.

RX/TX shift

Every time the PTT or the tone key button is pressed - or acknowledge is sent after receiving a selective call, the control logic will shift the power supply from RX to TX mode turning off the receiver and turning on the transmitter circuitry except the PA-driver stage and the antenna switch, which are turned on separately when proper lock has been established in the RF-synthesizer.

Frequency synthesizer control

The output frequency of the RF-synthesizer is controlled by two programmable dividers - one giving the channel spacing (reference frequency) - and one giving the actual RF-fre-

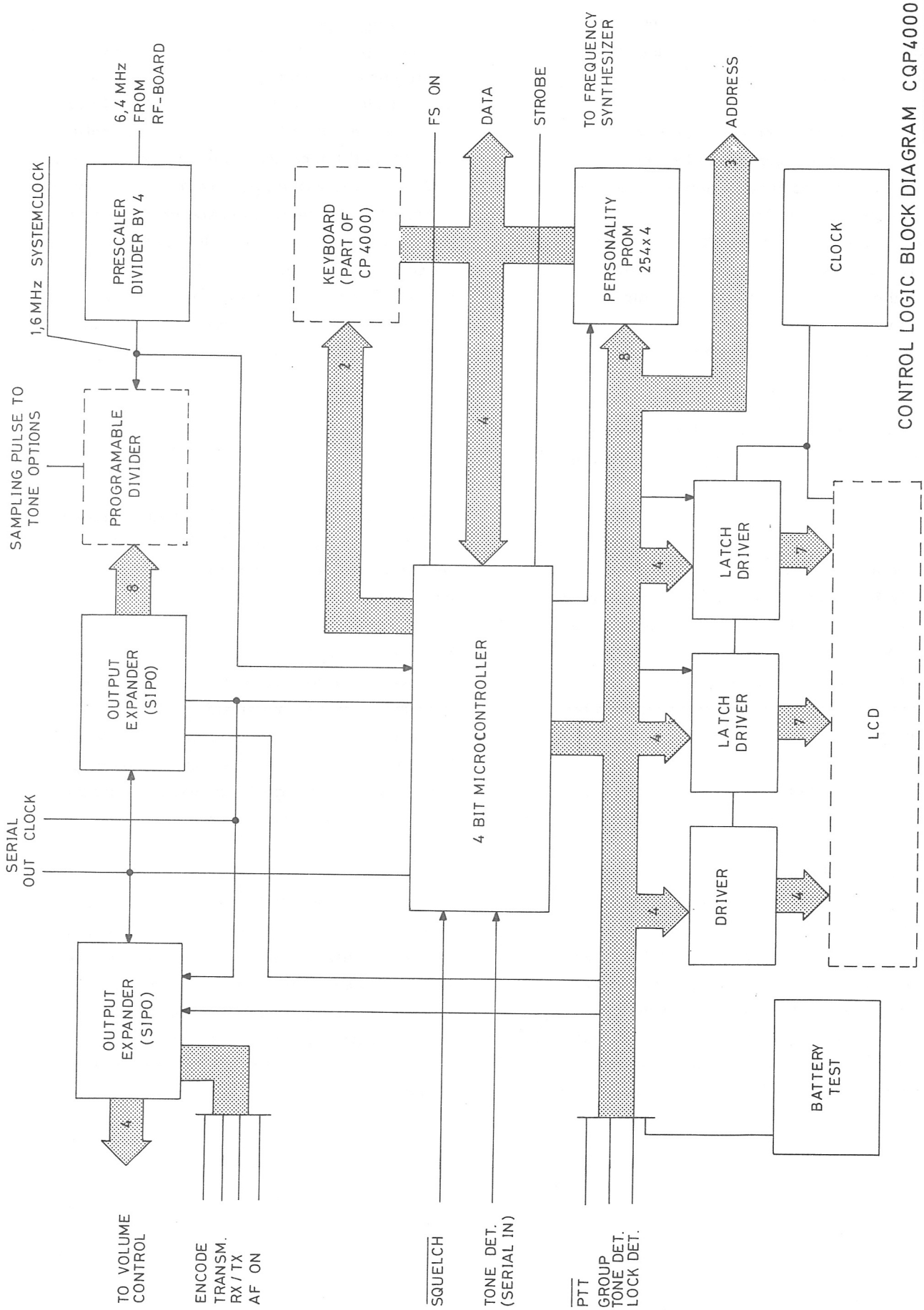

D 403.290

quency. The binary codes programming the dividers are stored in 8 four-bit latches inside the synthesizer.

The binary information corresponding to a given RF-frequency and channel spacing will be specified for each radio and programmed into the personality PROM.

The data transfer from the PROM to the synthesizer is controlled by the microcontroller. When the radio is turned on, the 8 nipples (4-bit words) specified for receiver channel 1 are loaded to the synthesizer.

Every time the channel select or the PTT button is pressed, new data for the alternate channel, respectively transmit are loaded to the synthesizer.

The microcontroller delivers a signal for turning on a part of the synthesizer only approximately 140 msec. every 1.6 sec. for current saving purposes. Every time the radio is turned ON or channel is switched, the current saving procedure is suppressed until a proper synthesizer lock signal is recognized by the microcontroller.

Current saving is not employed during transmit or in receive mode.

When the PTT button is pressed, the microcontroller shifts the power supply from RX to TX mode and loads the new data to the synthesizer. After a proper lock signal is recognized from the synthesizer, the antenna switch shifted to TX and RF-power is turned ON. If an out of lock signal is recognized during transmission, RF-power is turned off to prevent transmission on illegal frequencies.

#### Tone option control

The analog part of either a sequential tone module or a CTCSS tone-module is provided as separate optional thickfilm modules. These modules are controlled by the microcontroller such that all the control, the selection of tones and the timing will be performed by the control logic, while the generation and detection of tones is done in the tone module itself.

By coding the modewords in the personality PROM it is possible to determine the functional behaviour of the tone-system according to the options installed and the wanted facilities.

#### OPTIONS

The tone modules are plug-in thickfilm hybrid circuits. The personality PROM, placed on the control board, is programmed according to the tone system.

#### Sequential tone option

The sequential tone options are all based on the same thick film substrate.

By installing one of these modules and coding the personality PROM, it is possible to design a sequential tone-signalling system as described in the following subsections.

#### Sequential tone option control

Three basic sequential tone systems are available: EEA, ZVEI and CCIR with a tone-timing of respectively 40 ms, 70 ms and 100 ms. Selection is done by programming the proper tone-frequencies into the personality PROM together with tone timing information.

Up to 2 operator selectable tone digits can be specified.

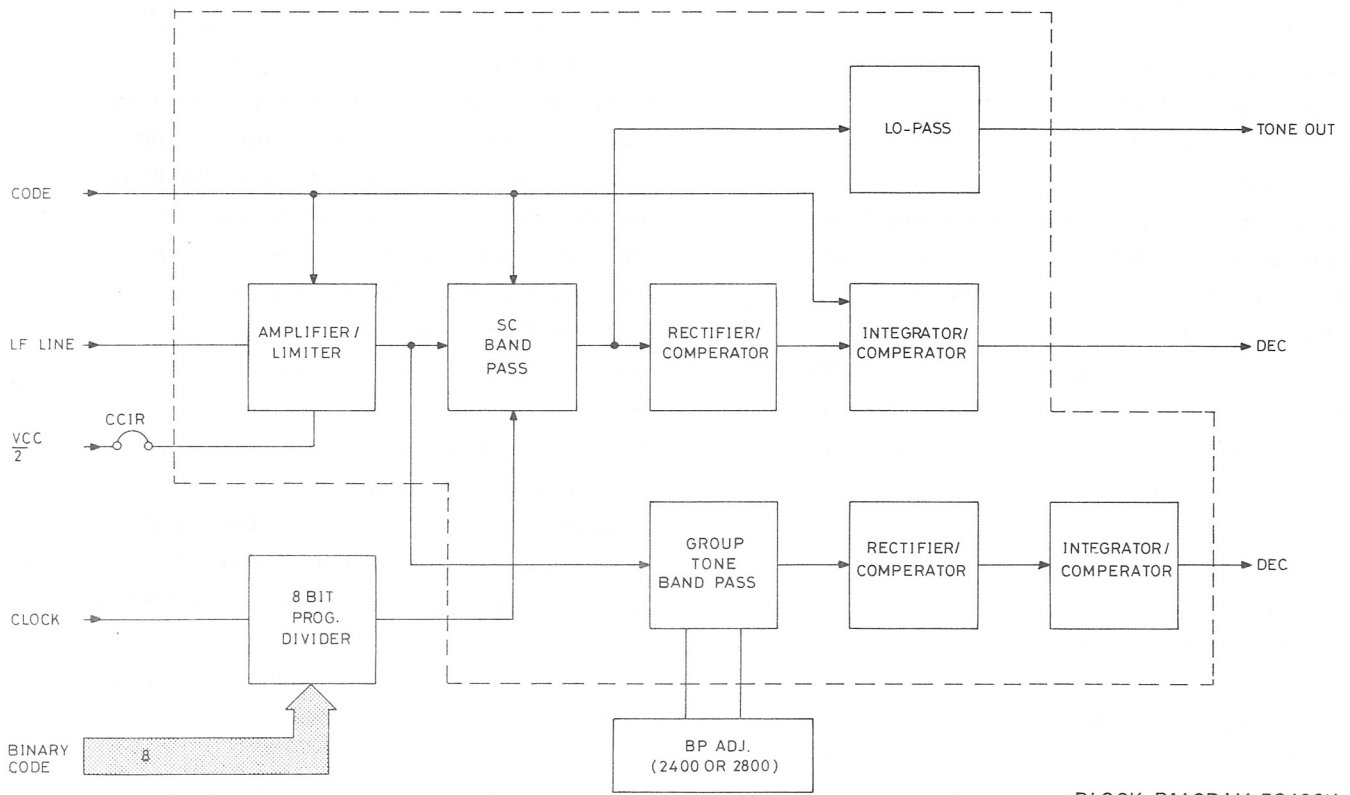

BLOCK DIAGRAM TQ400X

D403.292

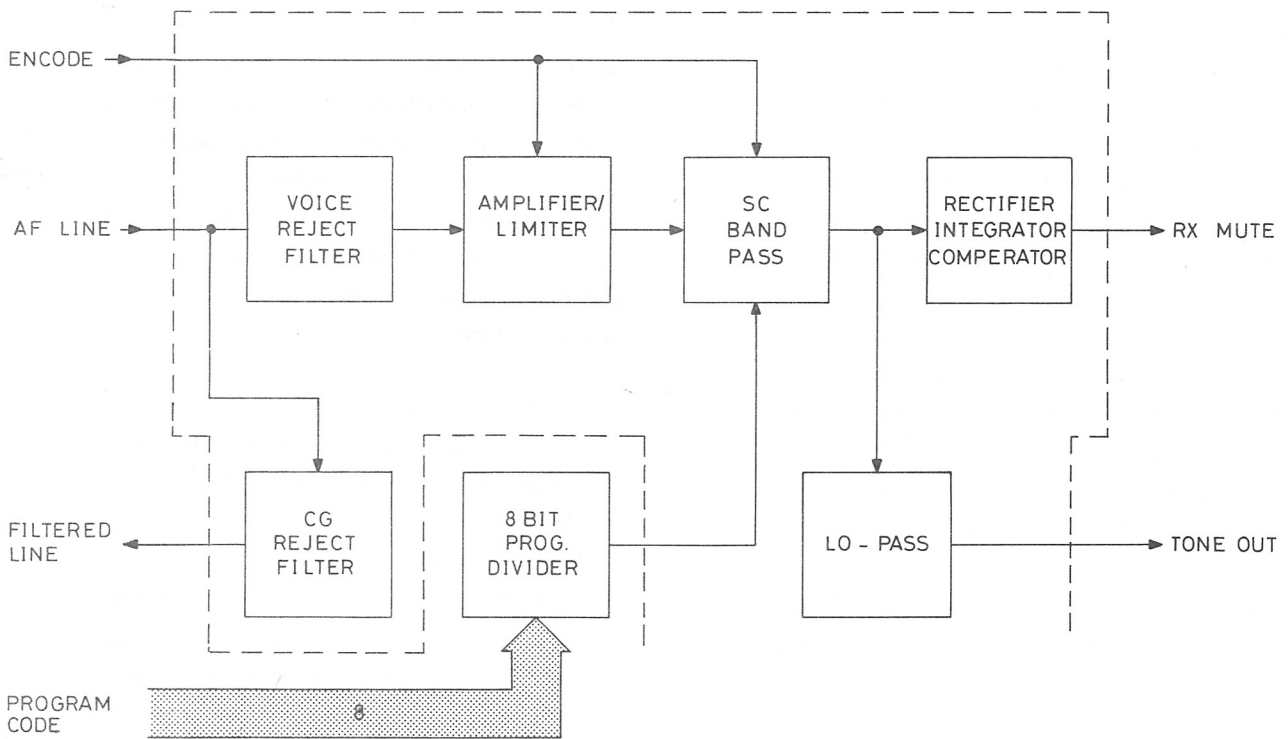

CHANNEL GUARD CIRCUIT CQP4000

D403.291

An operator selectable tone digit can be placed at any position in the encode telegram(s) - if required, in more than one position - instead of a fixed tone.

During tone transmission the tone, corresponding to the digit present in the display position, which is referenced at the telegram position(s), is produced by the encoder.

The encoder/decoder control is capable of handling automatic repeat-tone insertion. Before a tone-frequency code is loaded this tone is compared to the former tone, and if equal, the tone-frequency code for the repeat-tone will be loaded.

#### Sequential encoder

4 different combinations are available for tone encoder alone.

The presence of a TQ-module and the requirement of prolonged first tone, if used, is programmed into the MODEWORD, while the timing information (PREAMBLE - and TONE-TIMING) is coded into two separate positions. Each tone-telegram is specified as a sequence of tone numbers taken from the tone table (0-9 and A, B) while information words are coded as follows:

- C (hex): SEND NEXT TELEGRAM (STF)
- D (hex): SELECTABLE TONE "X1"
- E (hex): SELECTABLE TONE "X10"
- F (hex): END OF TELEGRAM

These data - words are programmed into the sequences as ordinary tones.

#### Sequential decoder

Three possible decoder options are available:

- decoder only
- one telegram with or without acknowledge
- two telegrams with or without acknowledge

In standby the first tone in the decoder-telegram (DEC) is loaded to the TQ and the tone-receiver waits for the first tone to be detected. If the nominal tonelength is less than 60 ms, then the second will be loaded as soon as the first has been accepted, otherwise the

tone receiver waits until the tone disappears, in order to be able to detect telegrams containing prolonged 1st tone. Every time a new tone is set up a reset timer having a length equal to the nominal tonelength plus 40 ms is started. Every time a tone is accepted the next tone is loaded, until the whole telegram has been received. If, during the reception, the reset timer overflows then the decoder is reset and the first tone reloaded to the TQ.

After reception of a correct tone call a one second attention-tone will sound in the loudspeaker and the bell and loudspeaker symbols on the display are turned on. If acknowledge is programmed the tone-transmitter is enabled.

The acknowledge-transmission takes place similar to normal tone-transmission activated by the operator.

Except for the ACK-telegram, which can contain up to 5 tones, all other telegrams may contain up to 7 tones.

#### Circuit description of seq. tone-option

The sequential unit is built around a Switched-Capacitor (SC) filter which is a specially suited active Band-Pass (BP) filter configuration, where each resistor is substituted by four bilateral switches and one capacitor, which - in conjunction - form an equivalent resistor. The value of this resistor is determined by the value of the capacitor and the sampling (or switching) frequency, applied to the bilateral switches.

#### Decoder operation

The tone to be received is amplified/limited from the 110 mV audio-line and fed through the BP filter.

The BP frequency is externally controlled by the sampling frequency, coming from the programmable divider - situated on the CL-board. The sampling frequency is divided from the reference oscillator frequency in the RF synthesizer. Internally the BP frequency can only be changed by a small trimming capacitor. After tuning the unit, it can be used in CCIR, ZVEI and EEA tone systems.

The programming code – to the divider – consists of 8 bit parallel data, which give a maximum deviation from the ideal BP center frequency of about 0.5%. The temperature stability is better than  $\pm 0.3\%$  over the specified temperature range.

The detector consists of a comparator and a retriggerable Monostable Multivibrator (MMV). The MMV is triggered/retriggered every time the signal from the BP filter exceeds the threshold level of the comparator. If the MMV is triggered/retriggered within every period of the certain tone, the capacitor in the integrator will start charging and a TONE DETECT output will be obtained.

#### Encode operation

In this case the amplifier/limiter is blocked and the SC filter is made self-oscillating. The programming codes for the tones are the same for decoder and encoder operation. The oscillator output is followed by a passive RC low-pass network and fed to the limiter in the TX audio processor, situated on the control board.

#### Group-tone decoder

When one of the TQ-units, TQ4002 to 7, is installed, the CQP4000 is capable of receiving a group-call on the following frequencies:

- TQ4002 + 5: ZVEI/CCIR 885/970 Hz
- TQ4003 + 6: ZVEI/CCIR 2400/2800 Hz
- TQ4004 + 7: EEA 1055 Hz

#### Group-tone decoder control

In a radio equipped with one of the above mentioned TQ's, the position for group-tone reception in the decoder-telegram must be programmed into the personality PROM. This position is given by a number from 1 to 7. If position 1 is coded the receiver will act as an All-call receiver. Coding the position ensures that a group-call will be accepted only at the specified position. When a group-tone has been received, the sequential decoder is reset immediately and the loudspeaker is opened without further indication.

#### Circuit description of group-tone receiver

The group-call decoder is coupled in parallel with the sequential-tone dec. and the two circuits have the amplifier/limiter in common. The selective part of the decoder consists of an active 2nd-order BP filter.

Different frequency determining capacitor values are used in the 885/970 Hz, 2400/2800 Hz and 1055 Hz assemblies. The BP center frequency can be adjusted.

The rectified BP-filter output is fed to a comparator in the detector. When the rectified level exceeds the threshold level of the comparator, the capacitor in the integrator will start charging and a group-detect output will be present.

It is possible to increase the integration time, so that the circuit can detect all call.

#### CTCSS option

It is possible to have CTCSS encoder alone or full encoder/decoder/filter combination. It is also possible to combine sequential tone-encoder with the full CTCSS combination or CTCSS-encoder (CGE) with full sequential tone option including group-call decoder. These combinations can be accomplished by the modules CG4001 to 3 and TQ4005 to 7.

#### CTCSS (CG) control

In the personality PROM there are positions reserved for the CTCSS frequency-codes, one for the CG-encoder (CGE) and one for the CG-decoder (CGD). If CGD is present the MODEWORD has to be coded with this information.

The CGE modulates the transmitter with a sub-audible tone as long as the transmitter is keyed, except during sequential tone-encoding. The CGD-decoder option performs the function of a tone squelch, so that the AF-channel is opened only if the correct CG tone is detected.

#### Circuit description of CTCSS option

The CTCSS circuits are built around Switch Capacitor filters.

CTCSS (CG) encoder (used in TQ4005-7)

The CG encoder is controlled by the same programmable divider as used in the sequential unit. Therefore the sequential encoder and the CG encoder can not encode simultaneously (the CG encoder is only enabled when the sequential encoder is disabled).

Only single tone encoding is possible, due to limitations in the programming (only 8 bits are

available). Therefore the self-oscillating SC band-pass filter is adjusted by a small capacitor.

The output from the oscillator is filtered by a passive RC low-pass filter - combined with an output blocking circuit - and fed to the input of the splatter-filter in the TX audio processor, situated on the CL-board.

The circuit is only supplied with power in the TX condition.



## CL4002

### CONTROL LOGIC

All control functions are concentrated around the microcontroller on a separate control board to which the tone-option is connected as a plug in module (thickfilm hybrid).

#### MICROCONTROLLER

The central part of the control logic is a 4-bit microcontroller with 1 K x 8 bit mask programmed memory (ROM) and 64 x 4 bit data memory (RAM). All timing and logical functions are processed by means of the internal software program.

#### INPUT/OUTPUT

The microcontroller has one 8-bit and one 4-bit bidirectional port, one 4-bit input port and one 4-bit output port. To expand the output capacity, the serial output port of the microcontroller is connected to two "serial in-parallel out" circuits.

#### PERSONALITY PROM

All data related to the individual radio are programmed into a 256 x 4 bipolar PROM identified as the "personality PROM", i.e. RF-frequency codes, Channel Guard tone specification, and optional information. The PROM-data are handled by the microcontroller software program.

#### DISPLAY DRIVERS

Four IC's are used to latch the data and drive the LCD-display. An approximately 40 Hz clock for the display is generated by two gates.

#### DISPLAY

The LCD-display contains 3 seven-segment digits and 5 separate symbols. The display is illuminated by 4 green LED's.

#### KEYPAD

The keypad is organized in a 2 x 4 matrix (one separate line for on/off) and contains all the operator controls except the PTT.

#### BATTERY VOLTAGE TEST

A voltage comparator gives a logic signal to the microcontroller when the battery-voltage drops below the specified limit.

#### ATTENTION TONE GENERATOR

Two gates are generating an approximately 1 kHz attention tone signal.

#### SOFTWARE

The software serves the purpose of functionally linking the different hardware modules together.

The microcontroller gets its inputs from the keyboard, the PTT-button, the tone-detect outputs, the FS-lock detect and the squelch. The information is decoded by means of the software to decide the actions to be executed in order to accomplish the proper output functions. The software program consists of a main loop and some subroutines. Apart from the initialization block, each of the blocks in the main

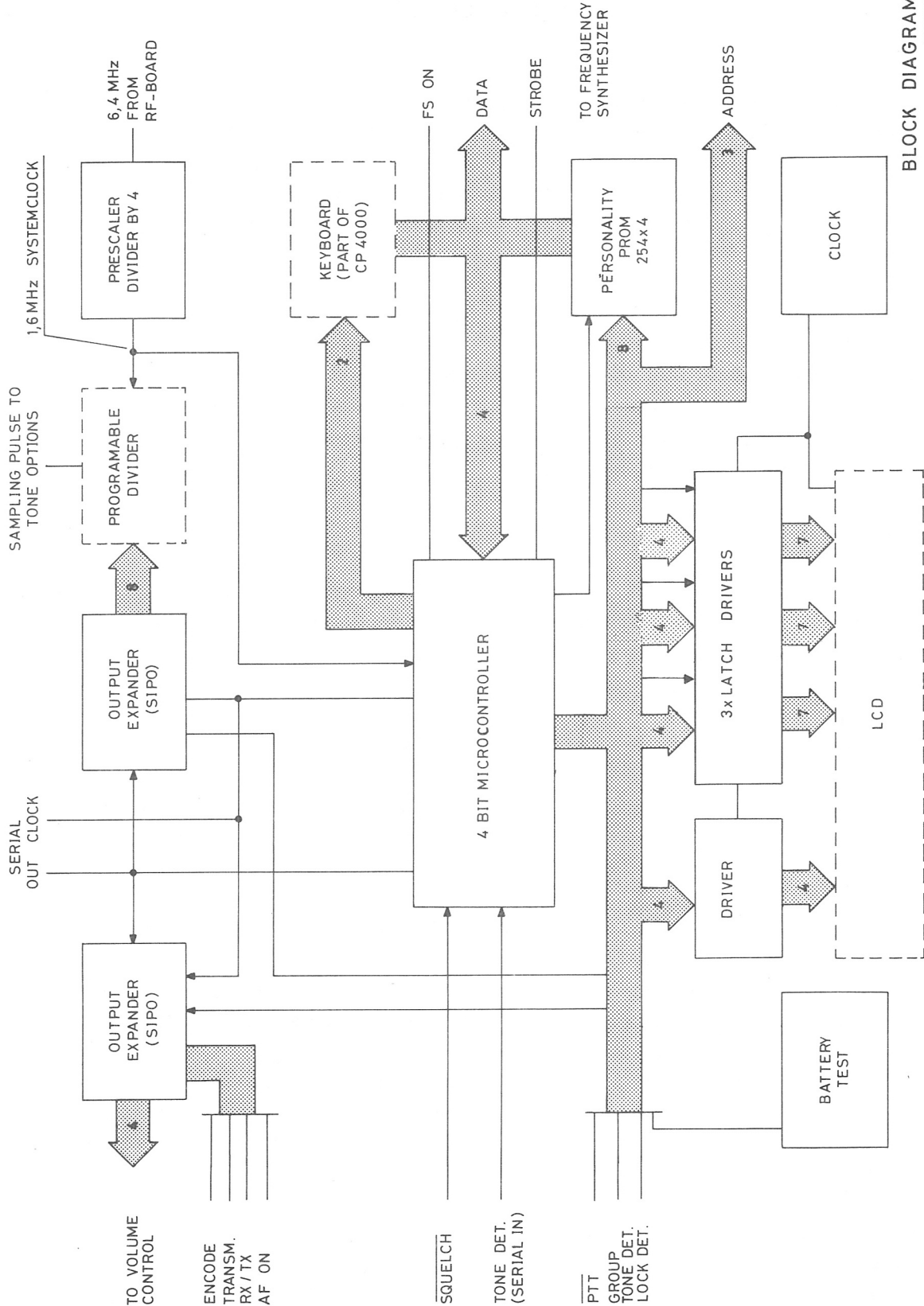

BLOCK DIAGRAM CL4002

D403.581

loop will be executed continuously. The actual status of the system decides how much of each program block that has to be executed. From the main loop it is possible to call the subroutines which perform the functions required in several of the main program blocks.

The allocation of program memory bytes for different purposes is indicated on the block diagram.

#### PERSONALITY PROM

The channel frequency codes, options and Channel Guard tone definition are programmed into a bipolar PROM, 256 x 4 bits.

To reduce power consumption, the PROM is only turned on when addressed by the microcontroller.

## CONTROL LOGIC FUNCTIONS

#### RF/AF CONTROL

The main portion of the general control functions in the radio is performed by the microcontroller and its peripheral circuits situated on the control board.

#### VOLUME CONTROL

The volume control is a digital/binary controlled attenuator circuit. The level is adjustable in 7 steps with approximately 5 dB per step. This function is realized by a resistive attenuator and an analog switch controlled by 3 bits coming from the microcontroller. The 4th bit breaks the line signal during the attention tone.

#### AUDIO AMPLIFIER

The audio output amplifier is in stand by mode turned off by a switch transistor in the supply line. The control logic will decide whether the audio amplifier is on or off, depending on the input from the receiver squelch and, if a tone option is installed, the input from the tone detector.

The audio amplifier is also turned on, either every time a button is pressed or when a selective call is received, to amplify the attention tone.

The audio processor consists of a microphone preamplifier, a splatter filter and a limiter. Adjustable resistors are setting the maximum frequency deviation and the Channel Guard deviation.

#### RX/TX SHIFT

Every time the PTT or the tone key button is pressed - or acknowledge is sent after receiving a selective call, the control logic will shift the power supply from RX to TX mode turning off the receiver and turning on the transmitter circuitry except the PA-driver stage and the antenna switch, which are turned on separately when proper lock has been established in the RF-synthesizer.

#### FREQUENCY SYNTHESIZER CONTROL

The output frequency of the RF-synthesizer is controlled by two programmable dividers - one giving the channel spacing (reference frequency) - and one giving the actual RF-frequency. The binary codes programming the dividers are stored in 8 four-bit latches inside the synthesizer.

The binary information corresponding to a given RF-frequency and channel spacing will be specified for each radio and programmed into the personality PROM.

The data transfer from the PROM to the synthesizer is controlled by the microcontroller. When the radio is turned on, the 8 nibbles (4-bit words) specified for receiver channel 1 are loaded to the synthesizer.

Every time the channel select or the PTT button is pressed, new data for the alternate channel, respectively transmit are loaded to the synthesizer.

The microcontroller delivers a signal for turning on a part of the synthesizer only approximately 140 msec. every 1.6 sec. for current saving purposes. Every time the radio is turned ON or channel is switched, the current saving procedure is suppressed until a proper synthesizer lock signal is recognized by the microcontroller.

Current saving is not employed during transmit or in receive mode.

When the PTT button is pressed, the microcontroller shifts the power supply from RX to TX

mode and loads the new data to the synthesizer. After a proper lock signal is recognized from the synthesizer, the antenna switch shifted to TX and RF-power is turned ON.

If an out of lock signal is recognized during transmission, RF-power is turned off to prevent transmission on illegal frequencies.

#### TONE OPTION CONTROL

The analog part of the Channel Guard module is provided as separate optional thickfilm module. This module is controlled by the microcontroller such that all the control, the selection of tones and the timing will be performed by the control logic, while the generation and detection of tones is done in the channel guard module itself.

By coding the modewords in the personality PROM it is possible to determine the functional behaviour of the tone-system according to the wanted facilities.

## OPTIONS

The tone modules are plug-in thickfilm hybrid circuits. The personality PROM, placed on the control board, is programmed according to the Channel Guard tones used on the respective channels.

#### CHANNEL GUARD OPTION

It is possible to have Channel Guard encoder alone or full encoder/decoder/filter combination.

#### CHANNEL GUARD CONTROL

In the personality PROM there are locations reserved for the Channel Guard frequency-codes, one for the CG-encoder (CGE) and one

for the CG-decoder (CGD). If Channel Guard is present on a channel its MODEWORD has to be coded with this information.

The Channel Guard Encoder modulates the transmitter with a subaudible tone as long as the transmitter is keyed. The Channel Guard decoder performs the function of a tone squelch, so that the AF-channel is opened only if the correct tone is detected.

#### CIRCUIT DESCRIPTION OF CHANNEL GUARD OPTION

The Channel Guard circuits are built around Switch Capacitor filters.

Only single tone encoding and decoding is possible, due to limitations in the programming (only 8 bits are available). Therefore the self-oscillating SC band-pass filter is adjusted by a small capacitor.

The output from the oscillator is filtered by a

passive RC low-pass filter - combined with an output blocking circuit - and fed to the input of the splatter-filter in the TX audio processor, situated on the CL-board.

The circuit is only supplied with power in the TX condition.

# TEST ADAPTOR

SE4002

The test adaptor is designed with the same dimension as a battery and fits into the battery compartment. The adaptor can be used to connect various test instruments to the radio and has built-in toggle switches to operate the radio during test and when adjusting the circuitry.

## 7.2 V CABLE

A cable terminated in two banana plugs, one red and one black, connects to the external power supply whose nominal output voltage should be +7.2 V.

## AF OUT CABLE

A coaxial cable terminated in a BNC plug is used to measure the receiver AF output, either the line output (nominal 110 mV) or the loudspeaker output, dependent on the setting of the AF-LINE switch.

## MOD. IN CABLE

A coaxial cable terminated in a BNC plug connects to an AF generator for external modulation of the transmitter. The test adaptor has a built-in 10:1 attenuator and the nominal modulation sensitivity as measured at the generator output is 110 mV/1 kHz

## TOGGLE SWITCHES

### KEY

switches between receive mode RX and transmit mode TX.

### AF-LINE

switches the AF out cable between the line output and the loudspeaker output.

### AF

switches the AF receiver output between the internal loudspeaker INT and a built-in 8 ohm dummy load.

### SQ

switches between the normal SQUELCH function and the unsquelched condition CANCEL.

### EN and TONE

are switches which when manipulated as described below key the transmitter and continuously modulate it with the first tone of the tone receiver code. The EN switch should always be in OFF position and the TONE switch in ON position unless the tone module is being tested.

The following procedure sets up the tone test mode:

1. Turn radio OFF
2. Set KEY to RX
3. Set EN to OFF
4. Set TONE to ON
5. Turn radio ON
6. Set TONE to OFF
7. Set KEY to TX
8. Set TONE to ON
9. Set EN to ON

The radio will now be in transmit mode and continuously modulated with a frequency which is the first tone of the tone receiver telegram code.

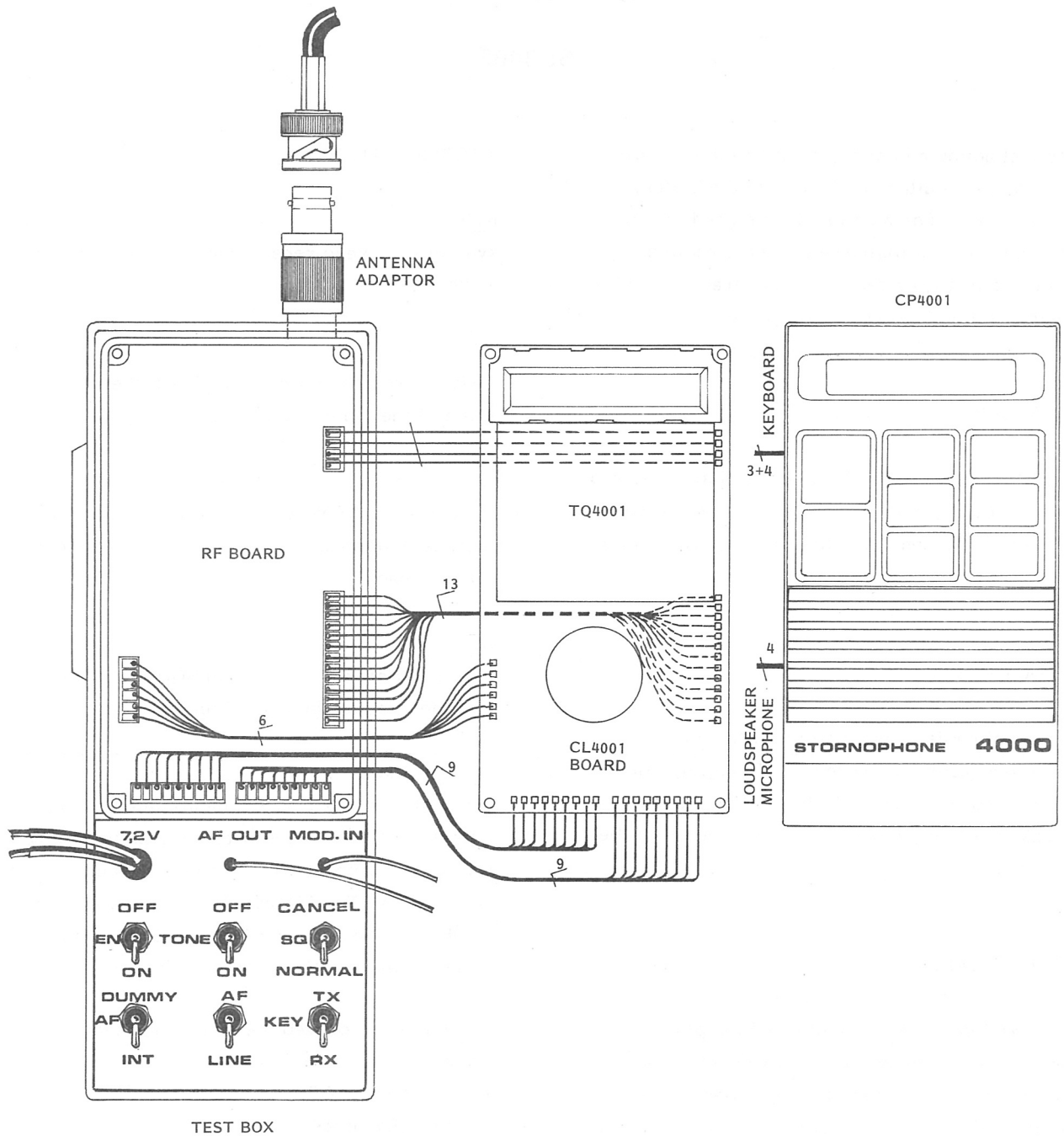

TEST SETUP  
STORNOPHONE 4000

D403.279

## ACCESSORIES DESCRIPTION

### CQP4000

#### BATTERIES

2 sizes of batteries are provided as options. A 450 mAh battery and a larger, 750 mAh battery.

The batteries are provided with two sets of terminals, one set in the top giving the supply to the radio and one set in the back for charging purposes. The charge - terminals are short circuit protected by means of a diode mounted in the battery.

Trans- mission	Receive	Stand by	Tone- options	Operation	
				2 W PA	1 W PA
5%	5%	90%	YES	6.3h	7.4h
2%	5%	93%	YES	9.8h	10.8h
5%	25%	70%	NO	5.3h	6.1h
2%	25%	73%	NO	7.6h	8.2h

#### Battery, 450 mAh

The battery pack consists of 2 moulded plastic parts, contact-strips, and 6 NiCd-cells with 450 mAh capacity. Nominal battery voltage is 7.2 V.

The operating time for a fully recharged battery is shown below (100% of nominal capacity):

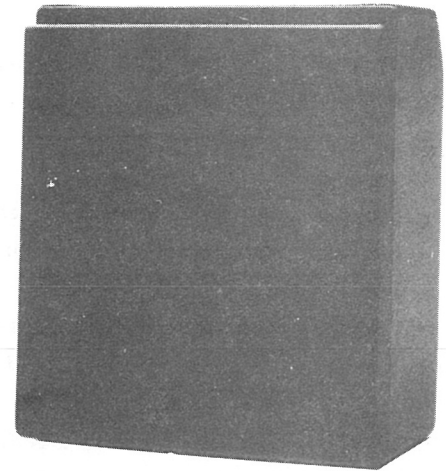

#### Battery, 750 mAh

The battery pack consists of 2 moulded plastic parts, contact-strips, and 6 NiCd-cells with

750 mAh capacity. Nominal battery voltage is 7.2 V.

The operating time for a fully recharged battery is shown below (100% of nominal capacity):

Trans- mission	Receive	Stand by	Tone- options	Operation	
				2 W PA	1 W PA
5%	5%	90%	YES	10.4h	12.3h
2%	5%	93%	YES	16.4h	18.1h
5%	25%	70%	NO	8.7h	10.0h
2%	25%	73%	NO	12.6h	13.6h

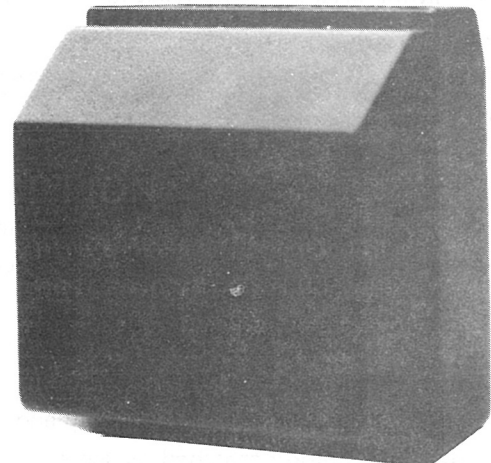



## ANTENNAS

Resonant helical antenna

The helical antenna is tuned to the transmitter frequency by an internal ferrite slug.



AN4xx1

Wide band conductive rubber antenna

This antenna is longer than the helical antenna and has better electrical performance.



AN4xx2

## OTHER ACCESSORIES

Carrying strap

The carrying strap is delivered as a kit containing:

1. Strap
2. Buckles
4. Clamps
1. Shoulder protector

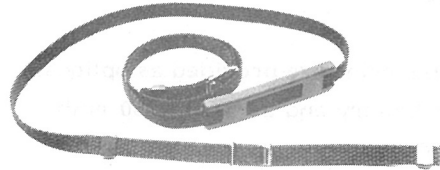

It is possible to cut the strap to any length and therefore to use it as a wrist-strap.

Carrying case

The carrying case is made of black leather. The display on the radio is visible through a window in the case.

The keypad and the battery are accessible after opening two flaps on the front of the case.

The carrying case may be used together with the carrying strap, but then the case has to be mounted before the strap is mounted.

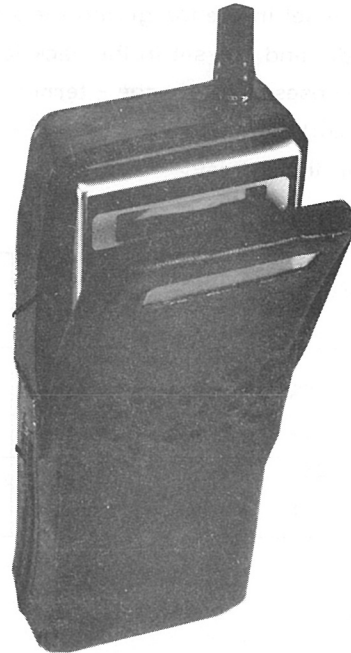
Battery tester

The battery tester is based on mechanical parts used for the radio-package.

A moving-coil instrument is placed in the front part, in the area normally used for the keypad.

The battery is placed in the battery compartment.

When the button on the left side (normally used for PTT) is depressed, the battery is loaded corresponding to the 2 W transmitter and the instrument will show the charge-condition.

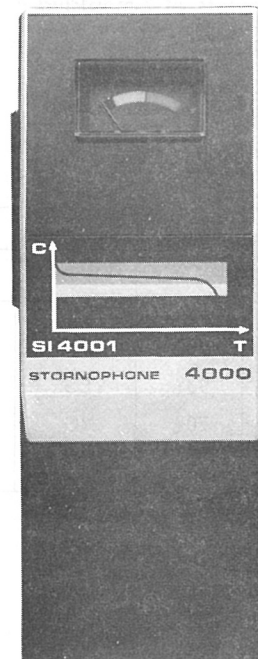
Display and keypad cover

A plastic cover to protect the display and keypad from being scratched by tools, etc. is available.

## BATTERY BU4001

The battery unit BU4001 is intended for use in STORNOPHONE 4000 radiotelephones.

The battery unit consists of 6 NiCd-cells connected in series.

The battery pack has two sets of terminals, a set for supplying the radio and a set for charging. This enables the unit to be charged separately or when in the radio.

Because of the big area of the charging terminals, a diode is connected between the positive terminal and the battery in order to avoid short-circuits when handling the battery. Furthermore, because the battery shall supply the charging unit in case of mains drop-out, a 470 ohm resistor is coupled parallel to the diode.

The third terminal (in the middle) of the charging inlet is designed for another version of the battery.

### NOTE:

A new battery may not reach full capacity until it has been charged/discharged 2 to 3 times.

After a longer period of storing, the capacity of the battery can be lower than its nominal capacity.

The battery must be started up, i. e. used with a few full charge/deep discharge cycles. Using the battery with full charge/deep discharge cycles from time to time will avoid storage and memory effects. A deep discharge corresponds to 6 V.

### SPECIFICATIONS

#### Capacity:

450 mAh nominal at 25°C.

#### Voltage:

7.2 V nominal at 25°C.

#### Charging current:

Max. 135 mA.

#### Charging temperature:

10 to 45°C.

#### Discharge temperature:

-25 to +60°C.

#### Storage temperature:

-40 to +60°C.

#### Internal resistance at 25°C:

DC resistance: 0.4 ohm max

AC resistance: 0.3 ohm max.

#### Dimensions

Length: 67.2 mm

Width: 67.4 mm

Height: 21.0 mm

#### Weight

150 g

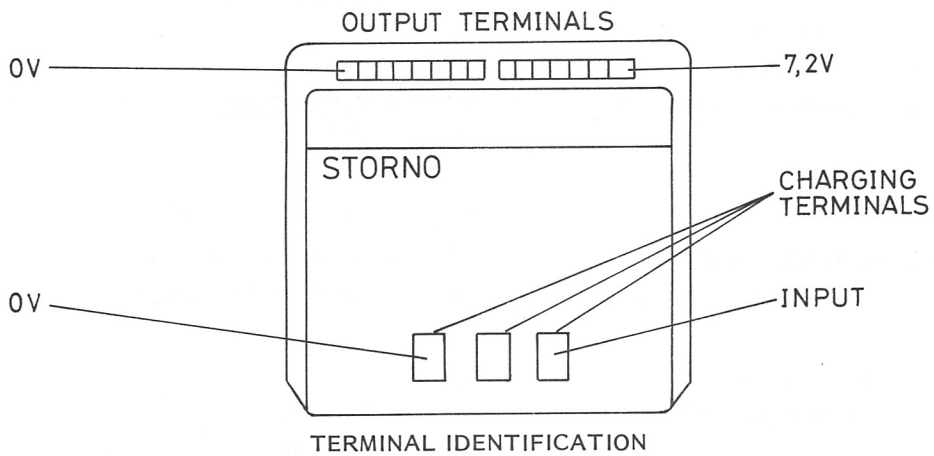
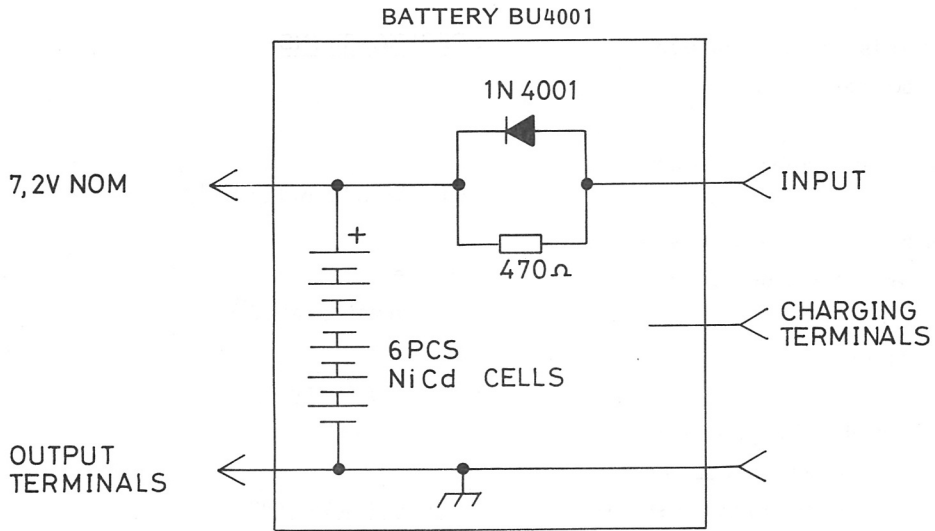

BU 4001

D403.315

## BATTERY CHARGER

### CU4001

The CU4001 battery charger is designed for the NiCd batteries BU4001 (450 mAh) and BU4002 (750 mAh).

The charger is available in a standard version and UK version with a special mains plug containing fuses.

The charger provides charging of either the battery alone or when inserted in the radio.

The charger is fully automatic, and the charging time is approximately:

- o 450 mAh battery - 6 hours
- o 750 mAh battery - 10 hours

The charging current is 120 mA. After nominal charging time (6 or 10 hours) the charger automatically switches to trickle charge with a charging current of 38 mA, thereby avoiding an overload condition that could damage the battery.

The battery contains a coding terminal, which automatically programs the charger for the right charging time so that the charger need not be adjusted to charge the two different battery types.

CU4001 is designed with two outlets, each provided with two LED-indicators.

- o Yellow LED - charging in process.
- o Green LED - charging finished.

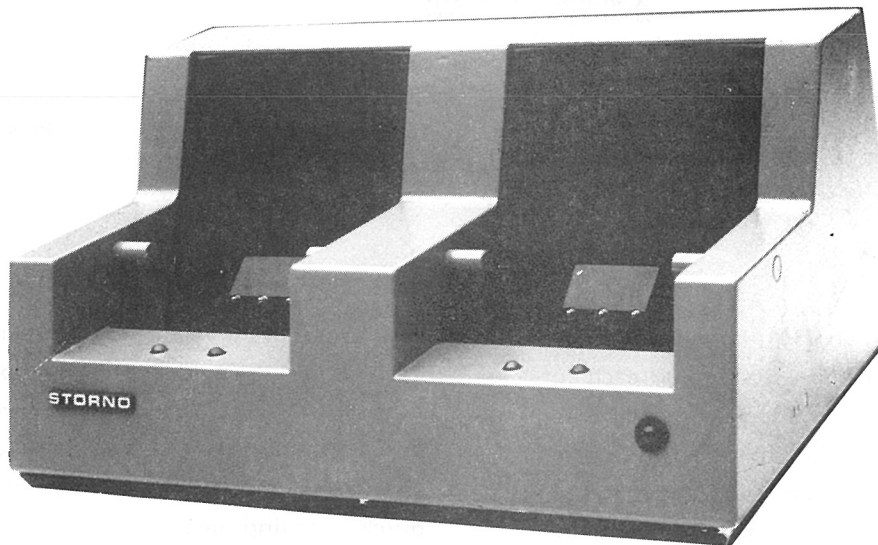

### CIRCUIT DESCRIPTION

The charger comprises two identical circuits, one for each of the two outlets.

The charging current is a rectified alternative current (100/120 Hz). The output AC voltage from the mains transformer is rectified and fed to the battery through a current limiting cir-

cuitry consisting of a zener diode (D201-D301) and a power transistor (Q201-Q301) providing a constant peak voltage drop across two series coupled resistors (R203/211-204, R303/311-304). R204/304 is short circuited during the predetermined period of quick charging. R203/211,

R303/311 thereby determine the quick charge rate. The standby charge rate is determined by

the series combination of the three resistors.

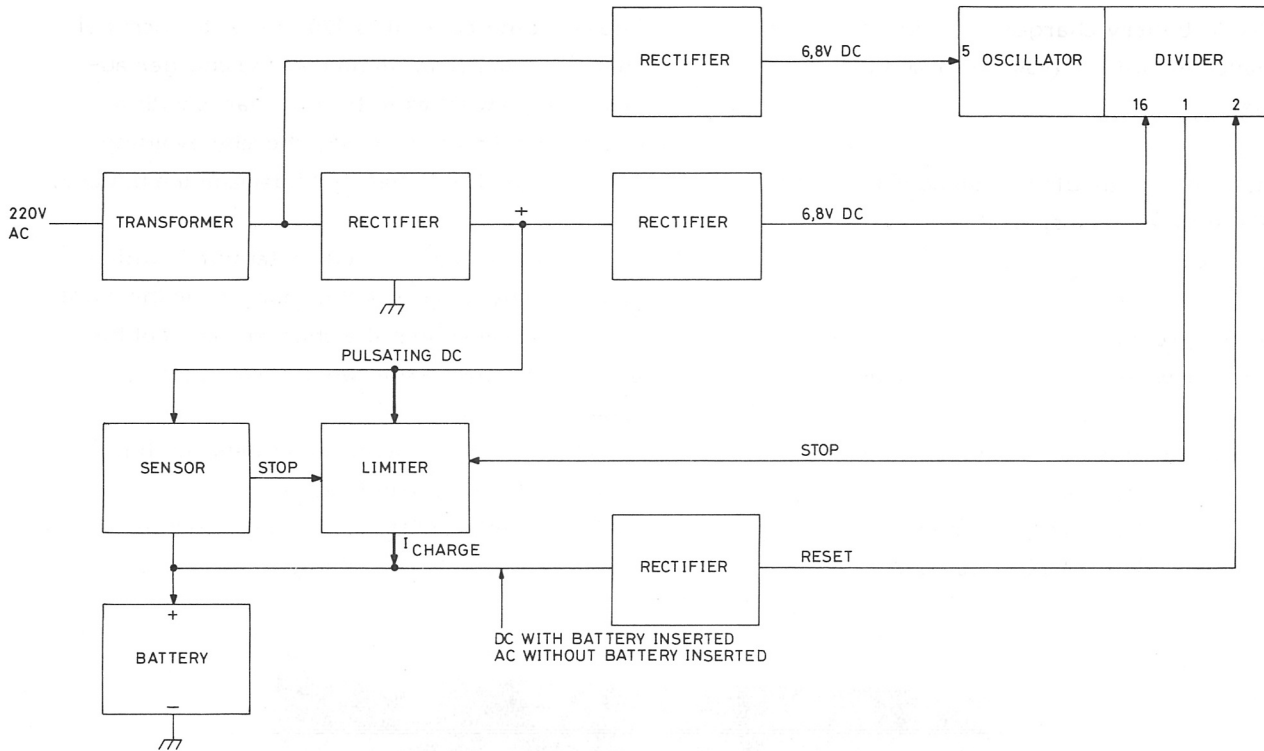

BLOCK DIAGRAM CU4001

D403.314

The timing circuit U201-U301, consists of a clock pulse oscillator and a divider for each outlet. The oscillator is only supplied from the mains transformer (Pin 5). The divider is supplied from the mains transformer and from the inserted battery (Pin 16), in order to maintain information of the elapsed quick charge time and to stop oscillation in case of mains dropout. The output voltage is limited to 11.5 V peak. The proper functioning of the timer is ensured by a resetting circuitry sensing whether there is an alternating voltage or a DC voltage at the battery outlet (Q203, D206, R212, R213). The

reset input of the frequency divider is at pin 2. Each outlet is provided with a yellow LED-indicator (H201-H301) to show that charging is in process and a green LED (H202-H302) to show that battery is ready after the predetermined quick charging time.

When a 750 mAh battery is inserted into the charger an extra contact strip in the battery connects a capacitor (C202) in the charger to ground whereby the oscillator frequency is lowered to prolong the charging time. The charger is short-circuit protected.

## TECHNICAL SPECIFICATIONS

NOTE: All charge currents are mean values.

Supply voltage

220/240VAC, +10%, -15% 50/60 Hz.

Mains transformer primary is strapped to either 220 V or 240 V nom.

Input current

Max. 45 mA

Input power

Max. 11 W

Temperature range

10 - 45 deg.C

Output voltage

$U_{\text{max.}} = 11.5 \text{ V}_{\text{peak}}$

Quick charge current at 220 V

min: 105 mA

typ: 120 mA

max: 135 mA

Standby charge rate at 220 V

min: 34 mA

typ: 38 mA

max: 42 mA

Short-circuit current

max. 80 mA (mean value)

Charging time/osc.frequency

450 mAh battery:

min: 4.8 h/480 Hz

typ: 5.3 h/435 Hz

max: 6.0 h/390 Hz

750 mAh battery:

min: 7.5 h/310 Hz

typ: 8.3 h/280 Hz

max: 9.1 h/250 Hz

## ADJUSTMENT PROCEDURE

### CQP4660

This adjustment procedure applies to the following types of STORNOPHONE 4000 radios:

- CQP4662: 400-470 MHz - 25 kHz channel spacing  
 CQP4663: 400-470 MHz - 20 kHz channel spacing  
 CQP4664: 400-470 MHz - 12.5 kHz channel spacing

Before making adjustments to the radio circuit, read the type label and note the channel frequencies and the tone system coding. Also check the personality PROM and its data against the type label information.

#### MEASURING INSTRUMENTS

The following measuring instruments are necessary for making service and adjustments to the CQP4660:

RF Signal Generator	400-470 MHz
AF Voltmeter	$Z_i > 0.5 \text{ Mohm}$
Multimeter	20 Kohm/V
Distortion meter	
Deviation meter	
Watt meter	0-2.5 W
AF Generator 50 Hz-5 kHz	$Z_{out} \geq 600 \text{ ohm}$
Frequency counter	5-200 MHz/50 mV
Power Supply	6-10 V/2 A
Signal Sampler	Storno D52
RF diode probe	Storno 95.0059-00
RF coil tuning tool	Storno 17.0053-00
Ref. oscillator tuning tool	Storno 19J707496G1
Test adaptor	SE4002 19K805371G1
Service kit	SE4003 19J707744G1
Consisting of service cabinet and antenna adaptor	
Extension cables	CC4001 19J707704G1

#### TEST BOX AND SERVICE CABLES

The test box fits into the battery compartment and remains connected to the radio during adjustment. The Service cables are used as extensions between the CL-board and the RF-board and should not be longer than 15 cm.

The test box has cables for measuring instruments and power supply voltage and the following control switches are mounted on the front:

<u>Switch</u>	<u>Function</u>
EN	Sequent. tone encoder ON/OFF
TONE	Tone encoder/Decoder test ON/OFF (5-tone and CG)
SQ	Squelch switch Normal= Squelch circuit active Cancel= Squelch circuit override (Loudspeaker open)
AF	INT/DUMMY switch Switches between the built-in loudspeaker and a dummy load (8 ohm).
AF/LINE	AUDIO switch Switches the AF OUT cable for the voltmeter between the loudspeaker output and the LINE output (110 mV at 70% $\Delta F_{max}$ ).
KEY	RX/TX switch Switches between receive (RX) and transmit (TX) mode.

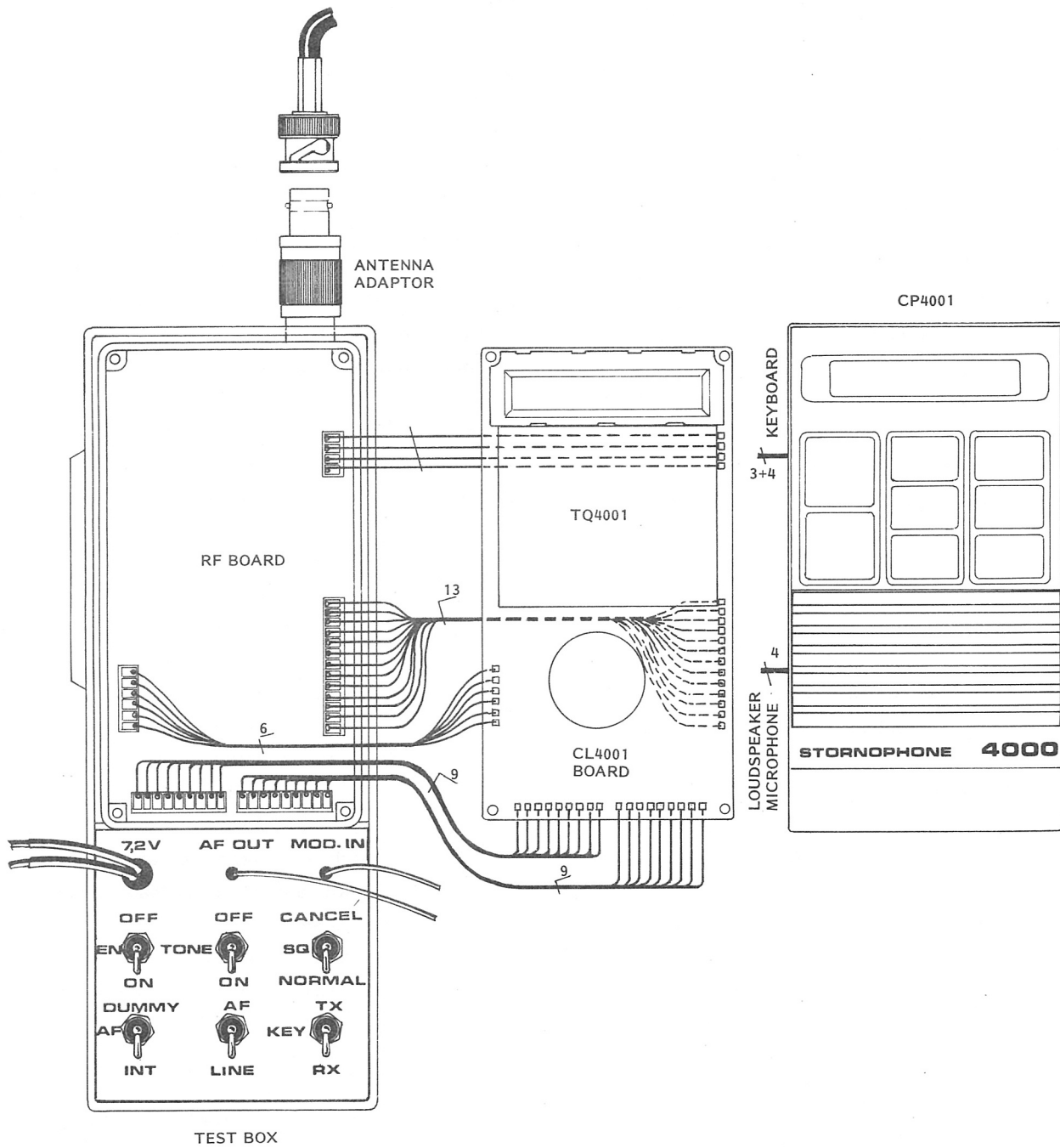

TEST SETUP  
STORNOPHONE 4000

D403.279



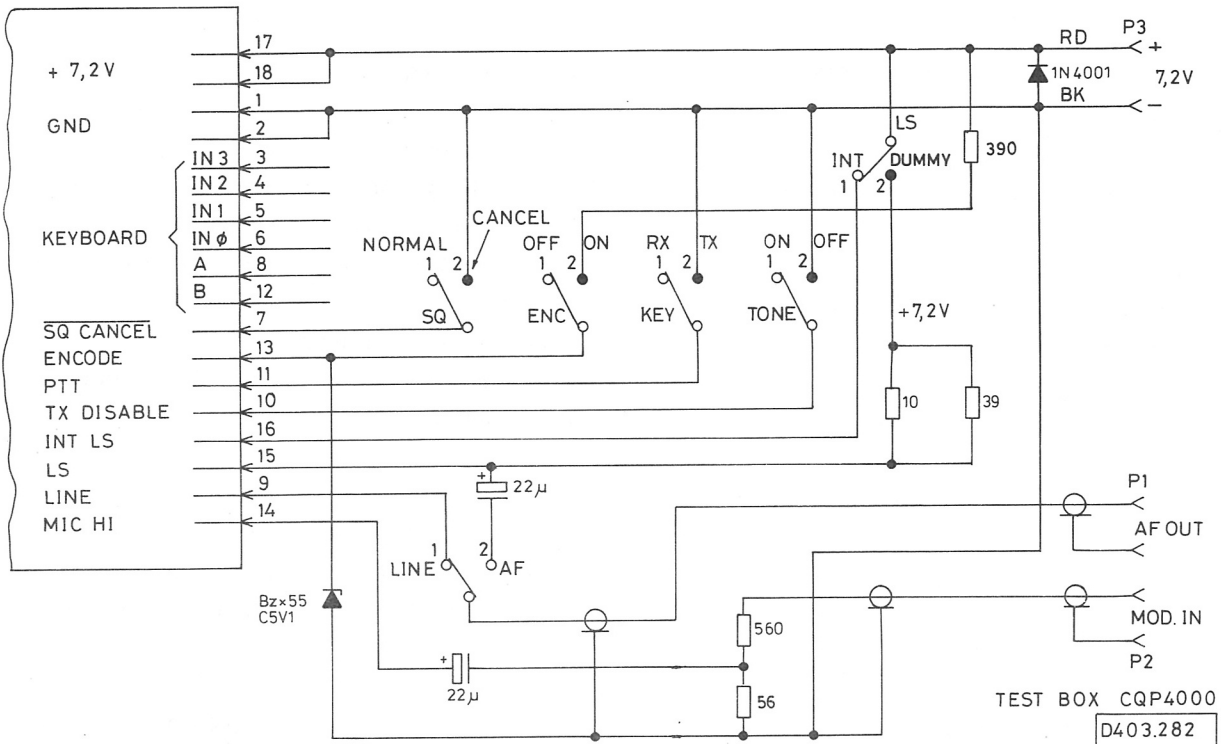

Cable	Function
7.2 V	Supply voltage cable Red (+) and black (-).
AF OUT	Audio output cable terminated with BNC connector. Output signal is either LINE or Loudspeaker signal depending on position of AF/LINE switch.
MOD. IN	Modulation input cable terminated with BNC connector. The cable connects the tone generator to the microphone input through a 10:1 attenuator (-20 dB).

**DISMANTLING OF CQP4000**

Before the CQP4000 can be adjusted the radio must be dismantled for access to all test points and adjustable components.

- Remove the battery, if inserted.
- Remove the two rear screws holding the cabinet.
- Remove the chassis box.
- Remove the four corner screws holding the front.
- Open the chassis box, carefully, without damaging the contact fingers on the rim.
- Take the CL4001 board and the RF4110 board apart.
- Connect the CL4001 board to the RF4110 board by means of the extension cables.
- Insert the chassis box in the service cabinet and firmly press the RF board to the bottom of the chassis box to establish good ground connections.
- Attach the antenna adaptor.
- Insert the test box in the battery compartment.
- The STORNOPHONE 4000 is now prepared for adjustment.

**TRANSMITTER ADJUSTMENT**

Refer to transmitter test setup.  
Set the power supply voltage to 7.2 V.  
Turn the radio on in receive mode and measure the current consumption.

Requirement: less than 30 mA.  
Connect the voltmeter to the +5.5 V test point.  
Read the 5.5 V regulated voltage.

### 1. SYNTHESIZER REFERENCE FREQUENCY ADJUSTMENT

Connect the frequency counter to P3 pin 13-CLOCK.

Read the reference frequency.

Check the reference crystal's frequency (6.4 MHz or 6.5 MHz).

Adjust C533 for  $f_{\text{nom}} \pm 10$  Hz.

Note:

The final adjustment of the reference frequency is performed later with closed chassis box.

### 2. TRANSMITTER VCO ADJUSTMENT

Set the ADC potentiometer to minimum, anti-clockwise.

Key the transmitter and read the current drain.

Requirement: less than 1 A.

Connect the voltmeter to P3 pin 7, OUT OF LOCK signal.

Adjust C504 for 0 V steady ready reading on the voltmeter. Connect the voltmeter to TP4.

Adjust C504 for a reading of 3 Volts. For radios with 2 channels adjust C504 so that the reading for each channel is inside the tuning range, 1-5 V. The channel with the lowest frequency has the lowest voltage reading.

### 3. TRANSMITTER POWER OUTPUT ADJUSTMENT

Connect the wattmeter to the antenna connector. Adjust ADC potentiometer R115 for rated output power according to the type designation.

Note:

The current drain at rated output power must not exceed 1 A.

### 4. TRANSMITTER FREQUENCY ADJUSTMENT

Connect the wattmeter to the antenna connector through the signal sampler.

Connect the frequency counter to the signal sampler.

Key the transmitter and read the frequency.

Adjust C533 for correct frequency. (C533 is fine adjusted later with closed chassis box).

Requirement:  $F_{\text{nom}} \pm 0.2$  ppm (225 Hz at 450 MHz)

Deenergize the transmitter.

Select channel 2, if used.

Key the transmitter and check for correct output frequency.

NOTE:

Adjustment of the transmitter frequency which also adjusts the receiver for correct frequency is done later when the chassis box is closed.

### 5. TRANSMITTER MODULATION ADJUSTMENT

Connect the deviation meter to the signal sampler.

Connect the AF generator to MOD IN on the test box.

Set the AF generator frequency to 1000 Hz and the output as follows:

1100 mV with test box (10:1 built-in attenuator)

Vary the AF frequency between 100 Hz and 3000 Hz and find peak deviation. Check the frequency for both + and - deviation. At the frequency producing peak deviation adjust R812 for maximum system deviation.

CQP4662:  $\pm 5$  kHz

CQP4663:  $\pm 4$  kHz

CQP4664:  $\pm 2.5$  kHz

Set the AF generator frequency to 1000 Hz. Reduce the AF generator output until a deviation of  $0.7 \times$  maximum deviation is obtained:

CQP4662:  $\pm 3.5$  kHz

CQP4663:  $\pm 2.8$  kHz

CQP4664:  $\pm 1.75$  kHz

Typical generator output is 100 mV.

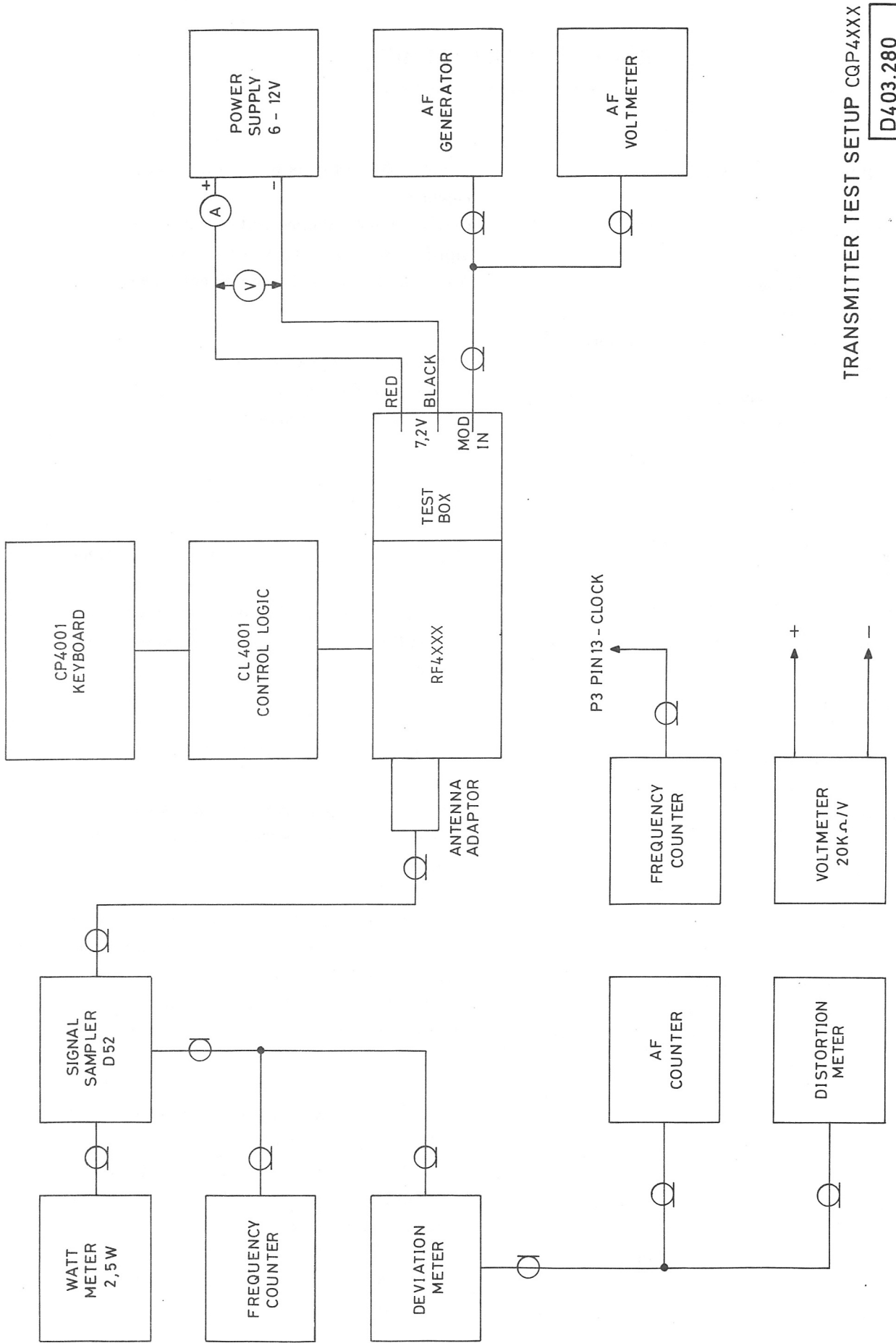

TRANSMITTER TEST SETUP CQP4XXX

D403.280

## RECEIVER ADJUSTMENT

Refer to receiver test setup.

### 1. RECEIVER VCO ADJUSTMENT

Connect the voltmeter to P3 pin 7, OUT OF LOCK signal.

Preset coil L508 as follows:

High end of band: 2/3 out of coil.

Low end of band: Fully down in coil form.

Set SQ switch to cancel.

Adjust C514 for 0 V steady reading on the voltmeter. Connect the voltmeter to TP4.

Adjust C514 for a reading of 3 Volts. For radios with 2 channels adjust C514 so that the reading for each channel is inside the tuning range, 1-5 V. The channel with the lowest frequency has the lowest voltage reading.

### 2. RECEIVER INJECTION SIGNAL ADJUSTMENT

Connect the diode probe and the voltmeter to TP2.

Adjust L508 for maximum voltmeter reading,  $0.13 \text{ V} \pm 0.02 \text{ V}$ . (L508 is readjusted together with the front-end).

### 3. IF SIGNAL ADJUSTMENT

Connect the signal generator to the antenna connector and set it to the channel frequency.

Modulate the signal generator with 1000 Hz to  $0.7 \times$  maximum system deviation.

CQP4662:  $\pm 3.5 \text{ kHz}$

CQP4663:  $\pm 2.8 \text{ kHz}$

CQP4664:  $\pm 1.75 \text{ kHz}$

Set the signal generator output to 100 mV.

Connect the diode probe and the voltmeter to TP3.

Reduce the signal generator output until voltage reading is less than 1 V.

Adjust L402 and L308 for maximum voltmeter reading.

Connect the AF voltmeter to AF OUT. Set the signal generator output to 100 mV.

Adjust L403 for maximum voltmeter reading.

### ALTERNATIVE PROCEDURE

Connect the distortion meter to AF OUT.

Adjust L403 for minimum distortion.

### 4. AF LINE LEVEL ADJUSTMENT

Connect the AF voltmeter to the AF OUT (J906 pin 14).

Set signal generator as described in paragraph 3.

Adjust R409 for a voltmeter reading of 110 mV  $\pm 5 \text{ mV}$ .

### 5. FRONT-END ADJUSTMENT

Connect the signal generator to the antenna connector and set its frequency to the channel frequency.

Modulate the signal generator as described in paragraph 3. Adjust the generator output to approx. 12 dB SINAD.

Connect a distortion meter to AF OUT.

Set the LS-LINE switch on the test box to LINE.

Set the SQ switch to cancel.

Adjust the following coils for minimum distortion. L508, L302, L303, L305, L307 and L306.

As the sensitivity increases during the adjustment decrease the signal generator output to maintain 12 dB SINAD.

Repeat the adjustments until no further improvement is possible.

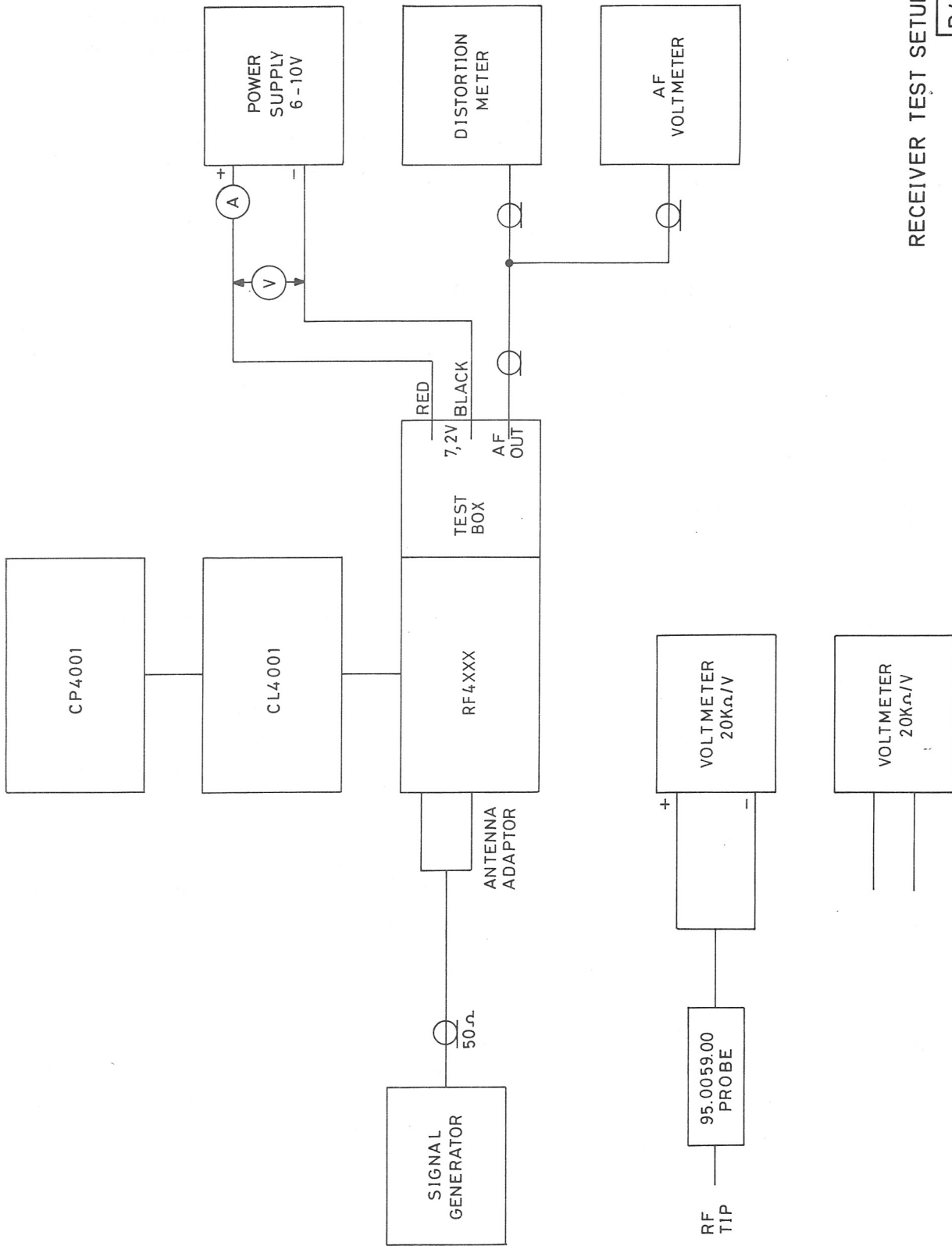

RECEIVER TEST SETUP CQP4XXX

D403.281

Check the 12 dB SINAD on both channels, if used.  
Requirement: 12 dB SINAD for less than 0.45 uV.

## 6. SQUELCH ADJUSTMENT

Turn the squelch potentiometer R420 completely anticlockwise to close the squelch.  
Open squelch by setting SQ switch to cancel.

Set the signal generator output to the value giving 12 dB SINAD.  
Close squelch by setting SQ switch to normal. Slowly turn R420 clockwise to the point where the squelch just opens.  
Vary the signal generator output slowly up and down to obtain the opening and closing level of the squelch.

Squelch opening level: 12 dB SINAD  
Squelch closing level: 6-10 dB SINAD

## FREQUENCY ADJUSTMENT

The reference oscillator frequency controls both the transmitter and receiver frequencies and final adjustment must be done with the chassis box properly assembled.

Turn the radio off and remove the test box. Assemble the radio but use the service cabinet to hold the chassis box.  
Connect the test box and turn the radio on.  
Connect a frequency counter to the signal sampler, refer to transmitter test setup.

Key the transmitter.

Adjust, through the hole in the rear of the service cabinet, the reference oscillator, C533 for nominal frequency.

Requirement:

$$F = F_{\text{nom}} \pm 0.2 \text{ ppm (225 Hz at 450 MHz).}$$

Switch to channel 2 and verify the frequency. (Channel switching is not possible while transmitting).

### ADJUSTMENT OF HELICAL ANTENNA AN4x1

The AN4x1 is adjusted by a ferrite slug which can be pulled up or pushed down inside the antenna radiator. The slug should be adjusted to a position where maximum power is being radiated.

Remove the antenna cap for access to the tuning wire (fish line).

Place the field strength indicator in upright position on a non-metallic surface of at least 50x50 cm.

Hold the radio in upright position and key the transmitter.

Adjust the distance between the radio and the signal strength indicator for a clear indication of signal pick-up.

Adjust by pulling the tuning slug up or down for maximum signal strength.

This adjustment is sensitive to proximity effects and the hand's position, and several positions should be tried for optimum result-check current drain which should not exceed 1 A.

Lock the tuning wire with the conical insert and cut the wire.

Mount antenna cap.

Note:

If a signal strength indicator D37 is not available a diode probe with a signal pickup wire and a multimeter or a deviation meter with a signal strength meter can be used to measure the radiated power.

## ADJUSTMENT OF TONEMODULE

### CQP4000

The tone module is available in different versions as tabulated below:

TYPE	TONE SYSTEM	CODE	ENC	DEC	GRP <sup>+</sup>	CG
TQ4001	ZVEI/CCIR	M905368G1	x	x		
TQ4002	ZVEI/CCIR	M905368G2	x	x	x	
TQ4003	ZVEI/CCIR	M905368G3	x	x	x	
TQ4004	EEA	M905368G4	x	x	x	
TQ4005	ZVEI/CCIR	M905368G5	x	x	x	x
TQ4006	ZVEI/CCIR	M905368G6	x	x	x	x
TQ4007	EEA	M905368G7	x	x	x	x

<sup>+</sup>The GRP option requires the group tone to be strapped on the TQ4000 module to one of the following tones: 885/970 Hz, 2400/2800 Hz, or 1055 Hz.

Connect the deviation meter to the signal sampler and an AF counter to the deviation meter's AF output.

Don't apply external modulation to the radio.

- Switch the radio OFF
- Set TONE switch to ON
- Switch the radio ON
- Set TONE switch to OFF
- Set ENC switch to ON
- Set KEY switch to TX

Check the deviation for being from 70-100% of maximum system deviation.

- CQP4112: ±3.5-5.0 kHz
- CQP4113: ±2.8-4.0 kHz
- CQP4114: ±1.75-2.5 kHz

Read the frequency at the AF output of the deviation meter.

The frequency should be the first tone of the decoder code.

Adjust, if necessary, the frequency with C113 on the TQ400x board for correct frequency according to the following table.

CCIR-EEA		ZVEI	
Nominal freq. Hz	Adjustment Freq. Hz	Nominal Freq. Hz	Adjustment Freq. Hz
1124	1120.6	1060	1057.9
1197	1202.1	1160	1159.9
1275	1271.5	1270	1271.5
1358	1363.2	1400	1406.7
1446	1453.1	1530	1537.6
1540	1537.6	1670	1673.8
1640	1632.5	1830	1836.5
1747	1739.9	2000	2003.5
1860	1862.4	2200	2203.9
1981	1973.6	2400	2404.2
2110	2098.9	2600	2592.8
2247	2241.2	2800	2813.4
1055	1057.9	885	887.5
		970	972.3

## CHANNEL GUARD TONE ADJUSTMENT

Connect the deviation meter to the signal sampler and an AF counter to the deviation meter's AF output. Don't apply external modulation to the radio.

Set ENC switch to OFF.

Set TONE switch to OFF.

Set KEY switch to TX.

Adjust R824 on CL4001 for specified deviation.

Read the frequency at the AF output of the deviation meter.

Adjust C305 on the TQ400x module for specified channel guard tone.

Tolerance:  $f_{CG} \pm 0.015 \text{ Hz}$

## ALL CALL ADJUSTMENT

When ALL CALL is programmed the TQ-module must be modified. Capacitor C209 is removed and replaced by an electrolytic capacitor 10  $\mu\text{F}$ /6 V, part nr. A700045P3; refer to D403.283 for location and polarization.

## GROUP TONE FREQUENCY ADJUSTMENT

Connect the signal generator to the antenna input. Modulate the generator with an external Tone test set e.g. TSG13 set to the group tone frequency so that a deviation of 33% of maximum system deviation is obtained.

CQP4112:  $\pm 1.65 \text{ kHz}$

CQP4113:  $\pm 1.32 \text{ kHz}$

CQP4114:  $\pm 0.825 \text{ kHz}$

Group tones:

885 Hz

970 Hz

1055 Hz

2400 Hz

2800 Hz

1981 Hz (special).

Modulation level - 47 dBm

Connect a AF voltmeter to the AF OUT.

Connect a voltmeter to TP201 on the TQ400x board.

Read the AF line level (AF OUT).

AF out= 35 mV  $\pm$  5 mV.

Adjust R821 on the CL4001 board for maximum voltage on the multimeter (5 V p.p  $\pm$  0.5 V).



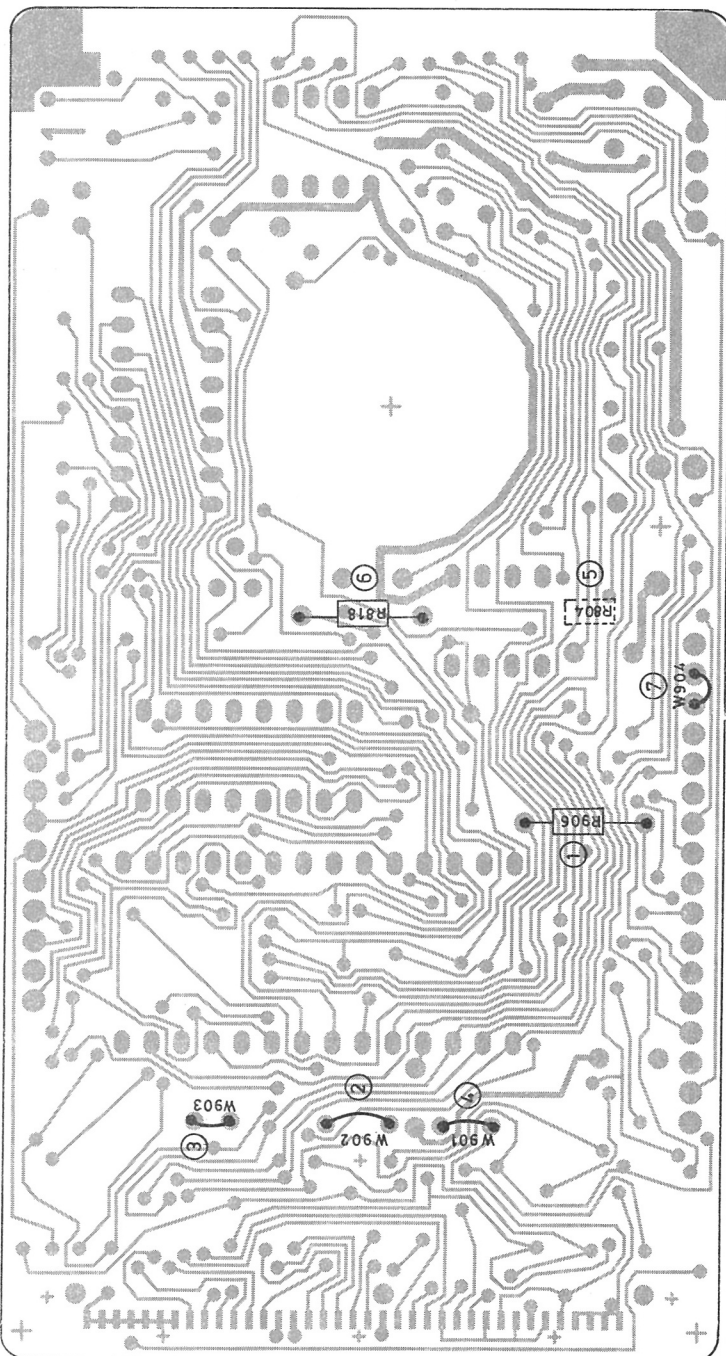

- ① REMOVE FOR NO ACOUSTIC FEED-BACK AND NO ALARM TONE
- ② CUT TO DISABLE LEFT TONE DIGIT ON DISPLAY (X10)
- ③ CUT TO DISABLE RIGHT TONE DIGIT ON DISPLAY (X1)
- ④ CUT TO DISABLE  $\downarrow$  - SYMBOL ON DISPLAY
- ⑤ R804 ON CHIP SIDE  
STANDARD MIC. SENSITIVITY : 330K  
+6dB                            : 680K  
-6dB                            : 150K
- ⑥ CUT FOR 12.5 KHz CHANNELSPACING AND SWEDEN (MOD. RESPONSE).
- ⑦ REMOVE IF TONE OPTION IS USED

**CONTROL LOGIC CL4001  
STRAPPING INSTRUCTION**

D403.383/2

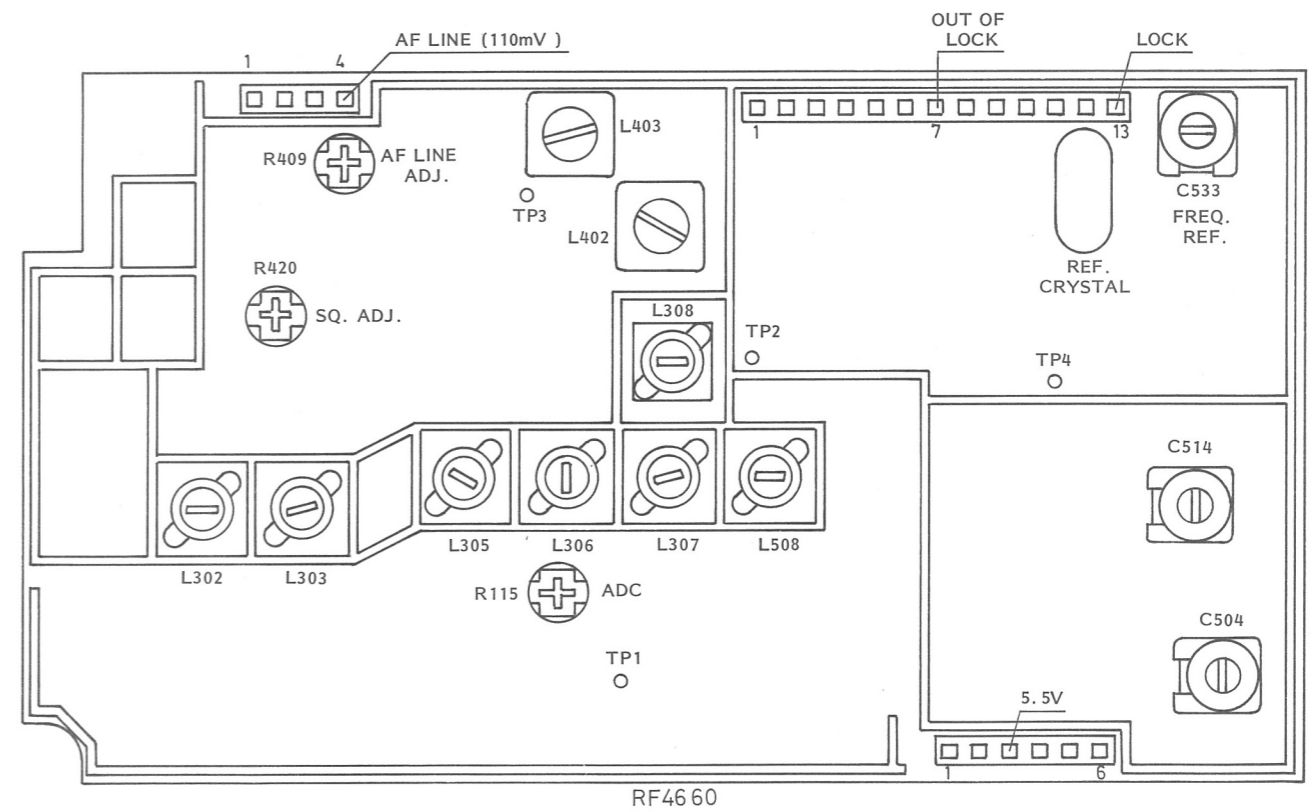
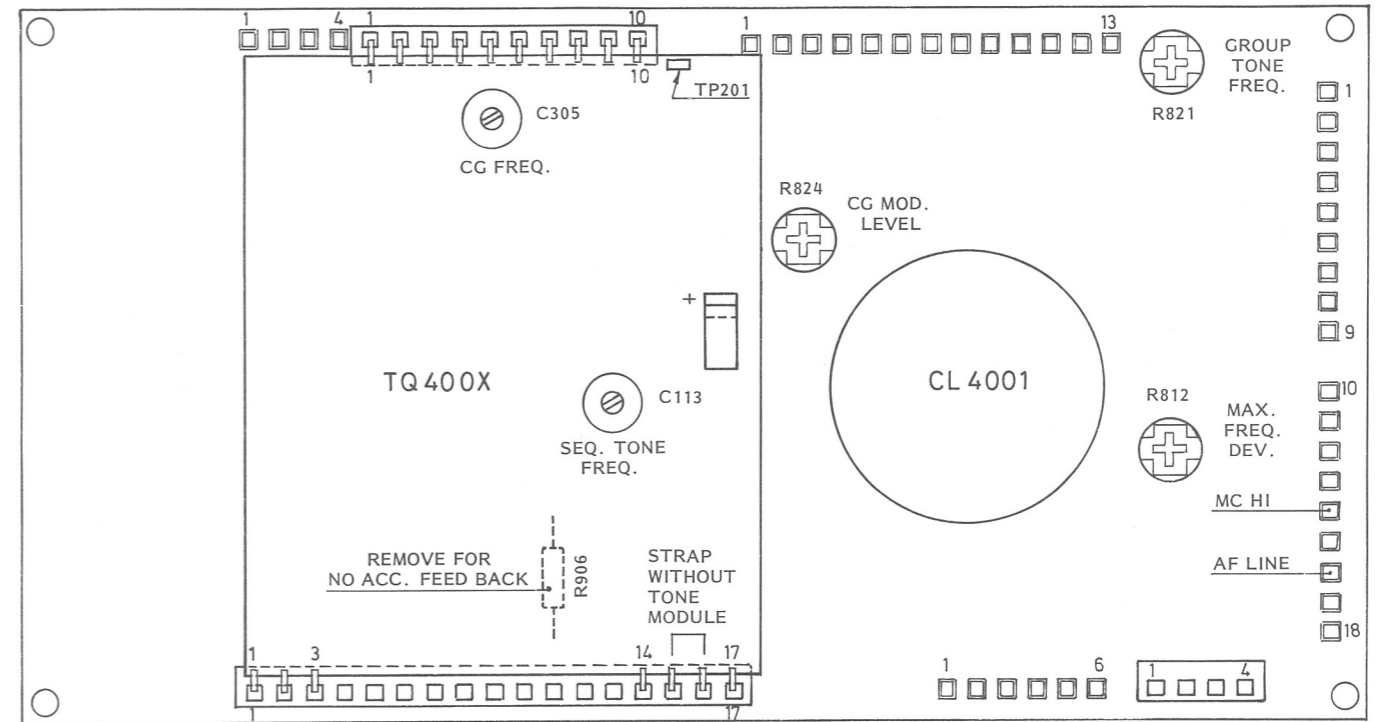

**TEST POINTS & ADJUSTABLE COMPONENTS**

TQ400X, CL4001, RF4660

**D403.465**

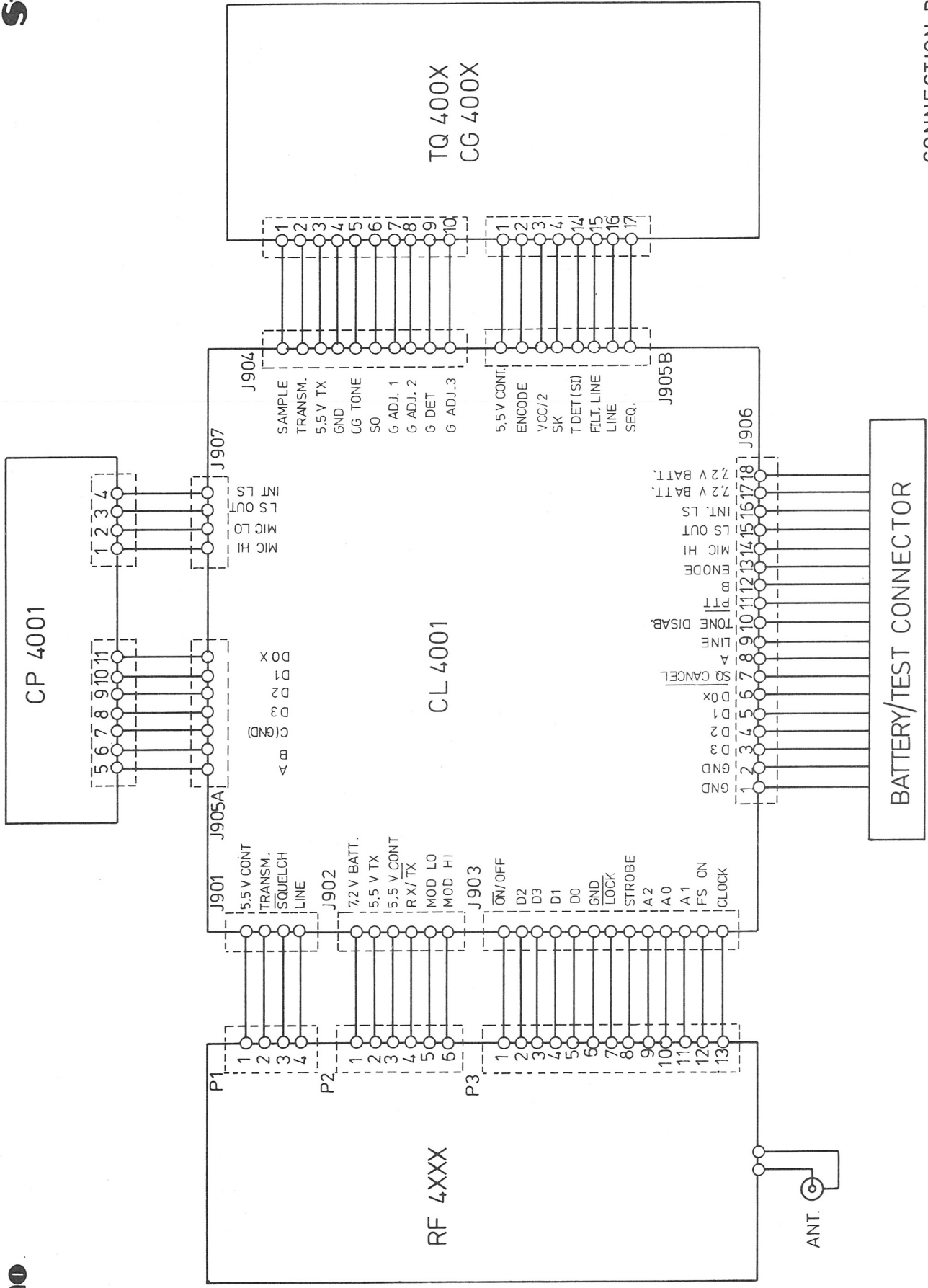

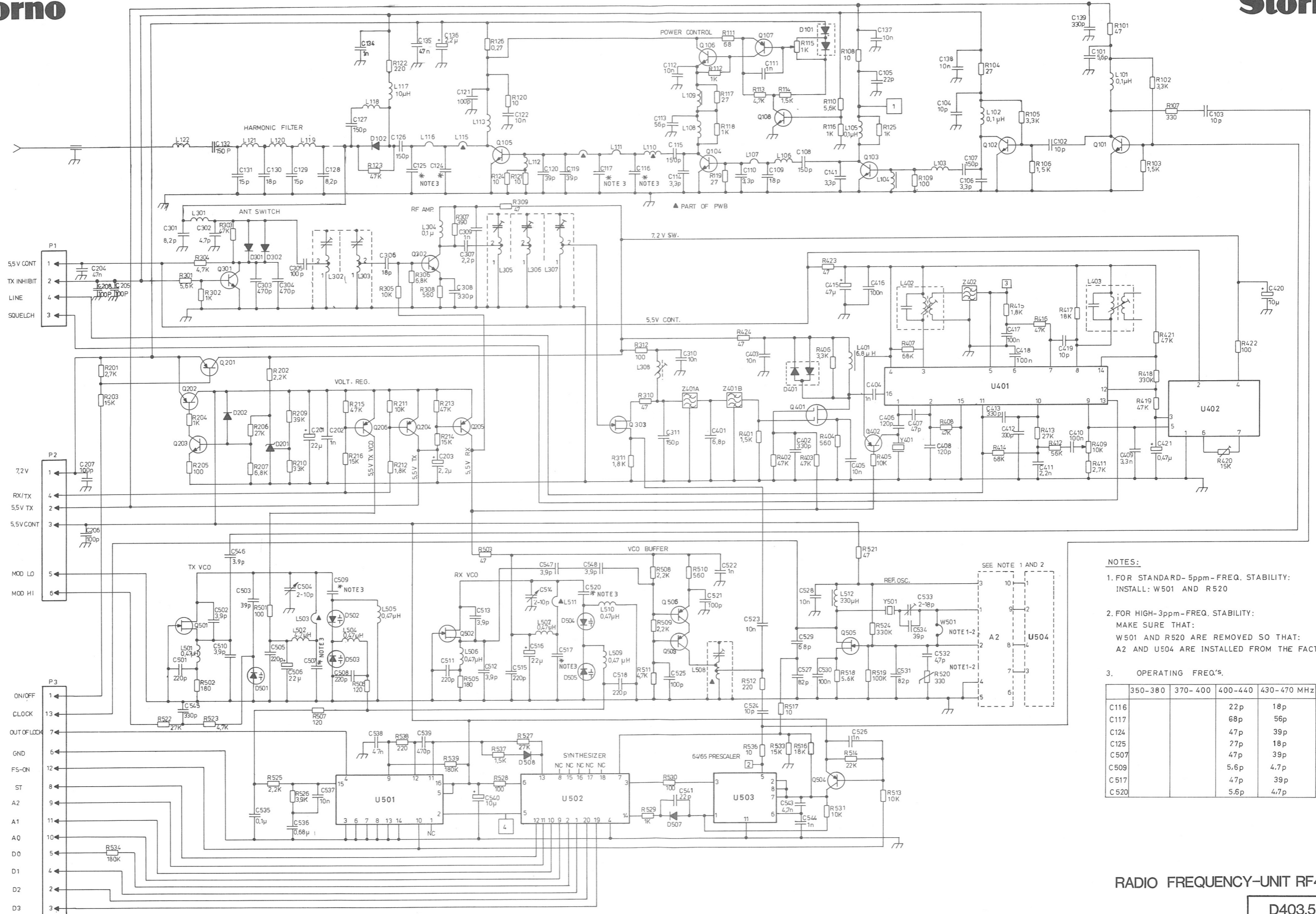

- NOTES:**
- FOR STANDARD-5ppm-FREQ. STABILITY:  
INSTALL: W501 AND R520
  - FOR HIGH-3ppm-FREQ. STABILITY:  
MAKE SURE THAT:  
W501 AND R520 ARE REMOVED SO THAT:  
A2 AND U504 ARE INSTALLED FROM THE FACTORY.
  - OPERATING FREQ.'S.

	350-380	370-400	400-440	430-470 MHz
C116			22 p	18 p
C117			68 p	56 p
C124			47 p	39 p
C125			27 p	18 p
C507			47 p	39 p
C509			5.6 p	4.7 p
C517			47 p	39 p
C520			5.6 p	4.7 p

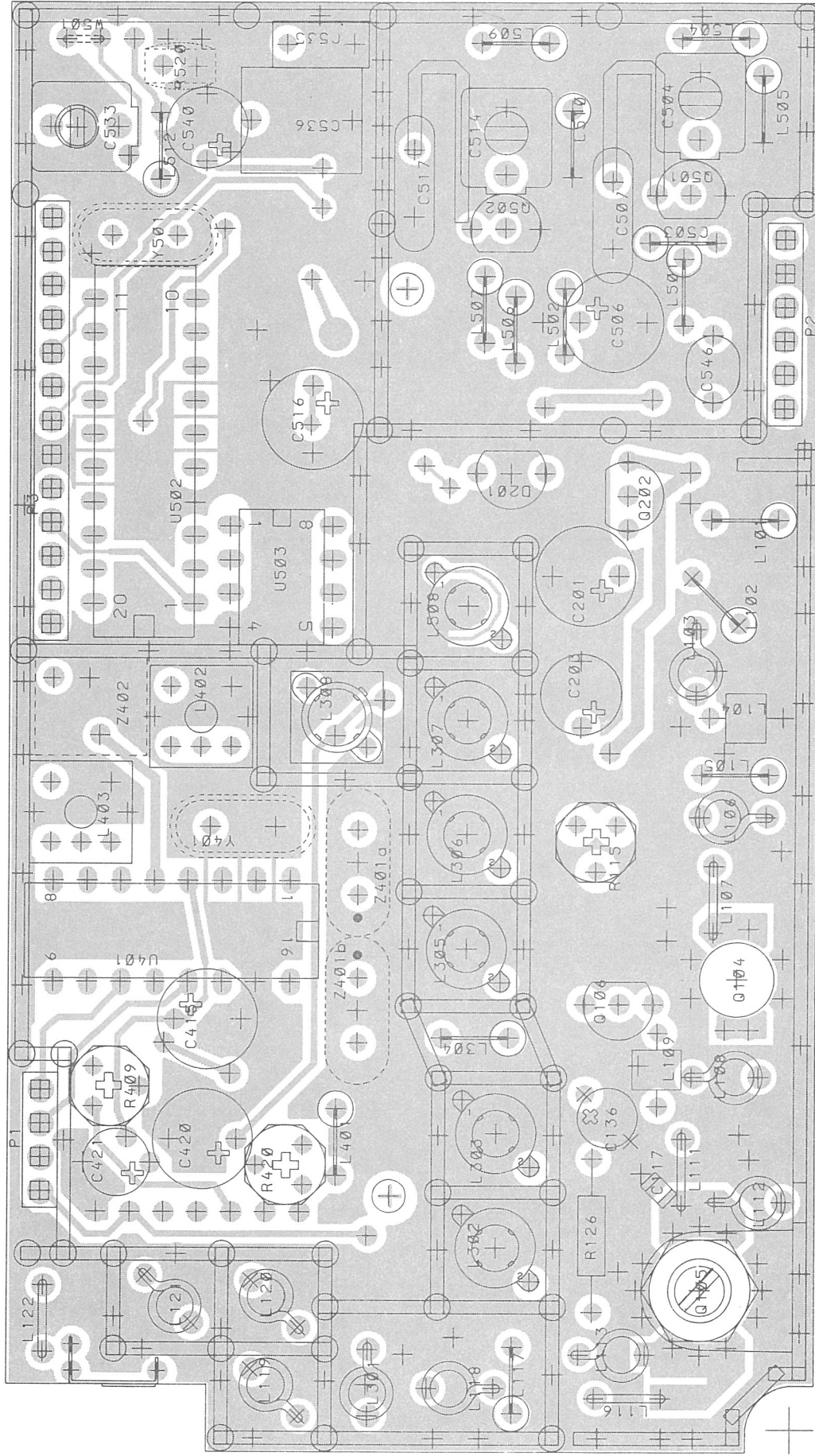

RADIO FREQUENCY-UNIT RF4660  
COMPONENT LAY-OUT  
COMPONENT SIDE

RF4660 H, 20/25 KHz CODE NO. M905468G1  
RF4660 L, 20/25 KHz CODE NO. M905468G2  
RF4660 H, 12,5 KHz CODE NO. M905468G3  
RF4660L, 12,5 KHz CODE NO. M905468G4

D403.463

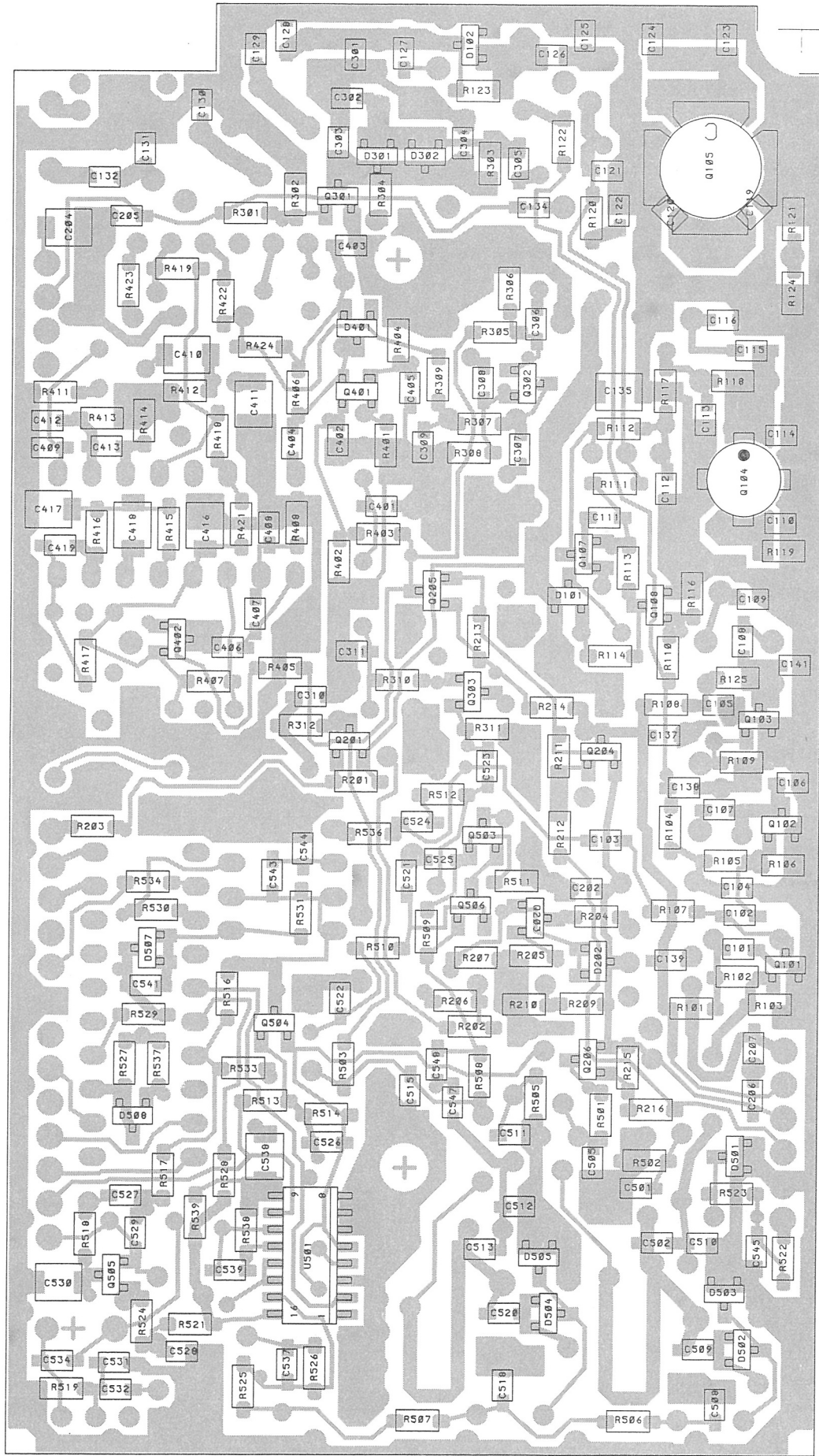

RADIOFREQUENCY-UNIT RF4660  
COMPONENT LAY-OUT  
CHIP SIDE

D403.462

ITEM NUMBER	DESCRIPTION
M905468G1	RF4660HI 470-430 MHZ, 25/20 KHZ CH. SPAC.
M905468G2	RF4660LO 440-400 MHZ, 25/20 KHZ CH. SPAC.
M905468G3	RF4660HI 470-430 MHZ, 12.5 KHZ CH. SPAC.
M905468G4	RF4660LO 440-400 MHZ, 12.5 KHZ CH. SPAC.

## P A R T S L I S T :

CIRCUIT POSITION	COMPONENT ITEM NUMBER	COMPONENT DESCRIPTION	WHERE APPLIED
	J706281P6	CORE	ALL
	J706804P2	WASH, INSULATION	ALL
	J707257P1	TUNING SLUG "SHORT" L=4MM,	M905468G2 /-G4
	J707257P1	TUNING SLUG "SHORT" L=4MM,	M905468G2 /-G4
	J707257P1	TUNING SLUG "SHORT" L=4MM,	M905468G2 /-G4
	J707257P1	TUNING SLUG "SHORT" L=4MM,	M905468G2 /-G4
	J707257P1	TUNING SLUG "SHORT" L=4MM,	M905468G2 /-G4
	J707257P1	TUNING SLUG "SHORT" L=4MM,	M905468G2 /-G4
	J707257P2	TUNING SLUG "LONG" L=6MM,	M905468G1 /-G3
	J707257P2	TUNING SLUG "LONG" L=6MM,	M905468G1 /-G3
	J707257P2	TUNING SLUG "LONG" L=6MM,	M905468G1 /-G3
	J707257P2	TUNING SLUG "LONG" L=6MM,	M905468G1 /-G3
	J707257P2	TUNING SLUG "LONG" L=6MM,	M905468G1 /-G3
	J707257P2	TUNING SLUG "LONG" L=6MM,	M905468G1 /-G3
	J707257P2	TUNING SLUG "LONG" L=6MM,	M905468G1 /-G3
	J707808P1	SPRING	ALL
	J707808P1	SPRING	ALL
	J707808P1	SPRING	ALL
	J707841G1	HEAT SINK, TINNED	ALL
	J707887G1	COV MACH.	ALL
	J707887G1	COV MACH.	ALL
	J707887G1	COV MACH.	ALL
	J707976P1	NUT HEX	ALL
	J708124P1	INSULATOR	M905468G3 /-G4
	K805392G1	SHLD MET	ALL
	L855385P1	SPRING ANTENNA	ALL
A2	L855339G1	CPNT BD. F.TEMP. COMP.	M905468G3 /-G4
C101	J707436P10	CAP CER 5,6PF 50V	ALL
C102	J707436P13	CAP CER 10PF 50V	ALL
C103	J707436P13	CAP CER 10PF 50V	ALL
C104	J707436P13	CAP CER 10PF 50V	ALL
C105	J707436P29	CAP CER 22PF 50V	ALL
C106	J707436P7	CAP CER 3,3PF 50V	ALL
C107	J707436P65	CAP CER 150PF 50V	ALL
C108	J707436P65	CAP CER 150PF 50V	ALL
C109	J707436P25	CAP CER 18PF 50V	ALL
C110	J707436P7	CAP CER 3,3PF 50V	ALL
C111	J707438P5	CAP CER 1NF 50V	ALL
C112	J707438P14	CAP CER 10NF 50V	ALL
C113	J707436P49	CAP CER 56PF 50V	ALL
C114	J707436P7	CAP CER 3,3PF 50V	ALL
C115	J707436P65	CAP CER 150PF 50V	ALL
C116	J707809P16	CAP CER 18PF 50V	M905468G1 /-G3
C116	J707809P17	CAP CER 22PF 50V	M905468G2 /-G4
C117	J707809P22	CAP CER 56PF 50V	M905468G1 /-G3
C117	J707809P23	CAP CER 68PF 50V	M905468G2 /-G4
C119	J707809P20	CAP CER 39PF 50V	ALL
C120	J707809P20	CAP CER 39PF 50V	ALL
C121	J707436P61	CAP CER 100PF 50V	ALL

CIRCUIT POSITION	COMPONENT ITEM NUMBER	COMPONENT DESCRIPTION	WHERE APPLIED
C122	J707438P14	CAP CER 10NF 50V	ALL
C124	J707809P20	CAP CER 39PF 50V	M905468G1 /-G3
C124	J707809P21	CAP CER 47PF 50V	M905468G2 /-G4
C125	J707809P16	CAP CER 18PF 50V	M905468G1 /-G3
C125	J707809P18	CAP CER 27PF 50V	M905468G2 /-G4
C126	J707436P65	CAP CER 150PF 50V	ALL
C127	J707436P65	CAP CER 150PF 50V	ALL
C128	J707809P12	CAP CER 8,2PF 50V	ALL
C129	J707809P15	CAP CER 15PF 50V	ALL
C130	J707809P16	CAP CER 18PF 50V	ALL
C131	J707809P15	CAP CER 15PF 50V	ALL
C132	J707809P27	CAP CER 150PF 50V	ALL
C134	J707438P5	CAP CER 1NF 50V	ALL
C135	J707438P22	CAP CER 47NF 50V	ALL
C136	J707353P5	CAP ELEC 2,2 UF 50V	ALL
C137	J707438P14	CAP CER 10NF 50V	ALL
C138	J707438P14	CAP CER 10NF 50V	ALL
C139	J707436P73	CAP CER 330PF 50V	ALL
C141	J707436P7	CAP CER 3,3PF 50V	ALL
C201	J707444P8	CAP TA 22 UF 16V	ALL
C202	J707438P5	CAP CER 1NF 50V	ALL
C203	J707444P5	CAP TA 2,2 UF 35V	ALL
C204	J707438P22	CAP CER 47NF 50V	ALL
C205	J707436P61	CAP CER 100PF 50V	ALL
C206	J707436P61	CAP CER 100PF 50V	ALL
C207	J707436P61	CAP CER 100PF 50V	ALL
C208	J707436P61	CAP CER 100PF 50V	ALL
C301	J707436P12	CAP CER 8,2PF 50V	ALL
C302	J707436P9	CAP CER 4,7PF 50V	ALL
C303	J707436P77	CAP CER 470PF 50V	ALL
C304	J707436P77	CAP CER 470PF 50V	ALL
C305	J707436P61	CAP CER 100PF 50V	ALL
C306	J707436P25	CAP CER 18PF 50V	ALL
C307	J707436P5	CAP CER 2,2PF 50V	ALL
C308	J707436P73	CAP CER 330PF 50V	ALL
C309	J707438P5	CAP CER 1NF 50V	ALL
C310	J707438P14	CAP CER 10NF 50V	ALL
C311	J707436P65	CAP CER 150PF 50V	ALL
C401	J707436P11	CAP CER 6,8PF 50V	ALL
C402	J707436P73	CAP CER 330PF 50V	ALL
C403	J707438P14	CAP CER 10NF 50V	ALL
C404	J707438P5	CAP CER 1NF 50V	ALL
C405	J707438P14	CAP CER 10NF 50V	ALL
C406	J707436P63	CAP CER 120PF 50V	ALL
C407	J707436P45	CAP CER 47PF 50V	ALL
C408	J707436P63	CAP CER 120PF 50V	ALL
C409	J707438P8	CAP CER 3,3NF 50V	ALL
C410	J707438P26	CAP CER 100NF 50V	ALL
C411	J707436P93	CAP CER 2,2NF 50V	ALL
C412	J707436P73	CAP CER 330PF 50V	ALL
C413	J707436P73	CAP CER 330PF 50V	ALL
C415	J707444P9	CAP TA 47 UF 6,3V	ALL
C416	J707438P26	CAP CER 100NF 50V	ALL
C417	J707438P26	CAP CER 100NF 50V	ALL
C418	J707438P26	CAP CER 100NF 50V	ALL
C419	J707436P13	CAP CER 10PF 50V	ALL
C420	J707444P7	CAP TA 10 UF 16V	ALL
C421	J707444P3	CAP TA 0,47 UF 35V	ALL



CIRCUIT POSITION	COMPONENT ITEM NUMBER	COMPONENT DESCRIPTION	WHERE APPLIED
C501	J707436P69	CAP CER 220PF 50V	ALL
C502	J707436P8	CAP CER 3,9PF 50V	ALL
C503	J707483P3	CAP PHEN 0,39PF 500V	ALL
C504	J707475P2	CAP VAR 2-10PF	ALL
C505	J707436P69	CAP CER 220PF 50V	ALL
C506	J707444P8	CAP TA 22 UF 16V	ALL
C507	J707870P20	CAP CER 39PF 50V	M905468G1 /-G3
C507	J707870P21	CAP CER 47PF 50V	M905468G2 /-G4
C508	J707436P69	CAP CER 220PF 50V	ALL
C509	J707436P10	CAP CER 5,6PF 50V	M905468G2 /-G4
C509	J707436P9	CAP CER 4,7PF 50V	M905468G1 /-G3
C510	J707436P8	CAP CER 3,9PF 50V	ALL
C511	J707436P69	CAP CER 220PF 50V	ALL
C512	J707436P8	CAP CER 3,9PF 50V	ALL
C513	J707436P8	CAP CER 3,9PF 50V	ALL
C514	J707475P2	CAP VAR 2-10PF	ALL
C515	J707436P69	CAP CER 220PF 50V	ALL
C516	J707444P8	CAP TA 22 UF 16V	ALL
C517	J707870P20	CAP CER 39PF 50V	M905468G1 /-G3
C517	J707870P21	CAP CER 47PF 50V	M905468G2 /-G4
C518	J707436P69	CAP CER 220PF 50V	ALL
C520	J707436P10	CAP CER 5,6PF 50V	M905468G2 /-G4
C520	J707436P9	CAP CER 4,7PF 50V	M905468G1 /-G3
C521	J707436P61	CAP CER 100PF 50V	ALL
C522	J707438P5	CAP CER 1NF 50V	ALL
C523	J707438P14	CAP CER 10NF 50V	ALL
C524	J707436P13	CAP CER 10PF 50V	ALL
C525	J707436P61	CAP CER 100PF 50V	ALL
C526	J707438P5	CAP CER 1NF 50V	ALL
C527	J707436P57	CAP CER 82PF 50V	ALL
C528	J707438P14	CAP CER 10NF 50V	ALL
C529	J707436P53	CAP CER 68PF 50V	ALL
C530	J707438P26	CAP CER 100NF 50V	ALL
C531	J707436P57	CAP CER 82PF 50V	ALL
C532	J707436P9	CAP CER 4,7PF 50V	ALL
C533	J707475P1	CAP VAR 2-18PF	ALL
C534	J707436P41	CAP CER 39PF 50V	ALL
C535	J707412P9	CAP PYES 100N 10% 63V	ALL
C536	J707612P2	CAP POL 0,68 UF 100V	ALL
C537	J707438P14	CAP CER 10NF 50V	ALL
C538	J707438P22	CAP CER 47NF 50V	ALL
C539	J707436P77	CAP CER 470PF 50V	ALL
C540	J707444P7	CAP TA 10 UF 16V	ALL
C541	J707436P29	CAP CER 22PF 50V	ALL
C543	J707438P8	CAP CER 3,3NF 50V	ALL
C544	J707438P5	CAP CER 1NF 50V	ALL
C545	J707436P73	CAP CER 330PF 50V	ALL
C546	J707870P8	CAP CER 3,9PF 50V	ALL
C547	J707436P8	CAP CER 3,9PF 50V	ALL
C548	J707436P8	CAP CER 3,9PF 50V	ALL
D101	J707389P1	DIO SI BAV 99	ALL
D102	J707391P1	DIO SI BAT 18	ALL
D201	J707448P1	DIO REF TL 431 CLP	ALL
D202	J707390P1	DIO SI BAV 70	ALL
D301	J707391P1	DIO SI BAT 18	ALL
D302	J707391P1	DIO SI BAT 18	ALL

CIRCUIT POSITION	COMPONENT ITEM NUMBER	COMPONENT DESCRIPTION	WHERE APPLIED
D401	J707389P1	DIO SI BAV 99	ALL
D501	J707769P1	DIO VAR CAP BBY 31	ALL
D502	J707769P1	DIO VAR CAP BBY 31	ALL
D503	J707769P1	DIO VAR CAP BBY 31	ALL
D504	J707769P1	DIO VAR CAP BBY 31	ALL
D505	J707769P1	DIO VAR CAP BBY 31	ALL
D507	J707390P1	DIO SI BAV 70	ALL
D508	J707390P1	DIO SI BAV 70	ALL
L101	J707486P1	COIL FIX 100NH	ALL
L102	J707486P1	COIL FIX 100NH	ALL
L103	J707426P3	COIL FIX 3 1/2 WIND.	ALL
L104	J707339G1	COIL FIX ASM	ALL
L105	J707486P1	COIL FIX 100NH	ALL
L106	J707426P2	COIL FIX 2 1/2 WIND.	ALL
L107	J707256P2	COIL FIX	ALL
L108	J707426P3	COIL FIX 3 1/2 WIND.	ALL
L109	J707339G1	COIL FIX ASM	ALL
L111	J707256P2	COIL FIX	ALL
L112	J707426P1	COIL FIX 1 1/2 WIND.	ALL
L113	J707426P1	COIL FIX 1 1/2 WIND.	ALL
L116	J707256P2	COIL FIX	ALL
L117	J707486P4	COIL,RF,FIXED 10 UH	ALL
L118	J707426P7	COIL FIX 7 1/2 WIND.	ALL
L119	J707426P2	COIL FIX 2 1/2 WIND.	ALL
L120	J707426P1	COIL FIX 1 1/2 WIND.	ALL
L121	J707426P1	COIL FIX 1 1/2 WIND.	ALL
L122	J707256P2	COIL FIX	ALL
L301	J707426P2	COIL FIX 2 1/2 WIND.	ALL
L302	J707816P3	COIL HELICAL	M905468G2 /-G4
L302	J707816P5	COIL HELICAL	M905468G1 /-G3
L303	J707816P3	COIL HELICAL	M905468G2 /-G4
L303	J707816P5	COIL HELICAL	M905468G1 /-G3
L304	J707486P1	COIL FIX 100NH	ALL
L305	J707816P4	COIL HELICAL	M905468G2 /-G4
L305	J707816P6	COIL HELICAL	M905468G1 /-G3
L306	J707816P3	COIL HELICAL	M905468G2 /-G4
L306	J707816P5	COIL HELICAL	M905468G1 /-G3
L307	J707816P4	COIL HELICAL	M905468G2 /-G4
L307	J707816P6	COIL HELICAL	M905468G1 /-G3
L308	J707422P3	COIL RF VAR	ALL
L401	J707486P3	COIL,RF,FIXED 6.8 UH	ALL
L402	J707431P1	COIL VAR 455 KHZ	ALL
L403	J707431P1	COIL VAR 455 KHZ	ALL
L501	J707486P6	COIL FIX 0,47 UH	ALL
L502	J707486P6	COIL FIX 0,47 UH	ALL
L504	J707486P6	COIL FIX 0,47 UH	ALL
L505	J707486P6	COIL FIX 0,47 UH	ALL
L506	J707486P6	COIL FIX 0,47 UH	ALL
L507	J707486P6	COIL FIX 0,47 UH	ALL
L508	J707816P4	COIL HELICAL	M905468G2 /-G4
L508	J707816P6	COIL HELICAL	M905468G1 /-G3
L509	J707486P6	COIL FIX 0,47 UH	ALL
L510	J707486P6	COIL FIX 0,47 UH	ALL
L512	J707486P5	COIL FIX 330 UH	ALL
P1	J707350P4	PLG 4-PIN	ALL
P2	J707350P6	PLG 6-PIN	ALL
P3	J707350P13	PLG 13-PIN	ALL

CIRCUIT POSITION	COMPONENT ITEM NUMBER	COMPONENT DESCRIPTION	WHERE APPLIED
Q101	J707388P1	TSTR BFR 53	ALL
Q102	J707388P1	TSTR BFR 53	ALL
Q103	J707388P1	TSTR BFR 53	ALL
Q104	J707763P1	TSTR NPN RF MFR 627	ALL
Q105	A702448P1	TSTR (2N5945) , RF POWER	ALL
Q106	J707673P1	TSTR NPN SI BC 368	ALL
Q107	J707387P1	TSTR BCW 30	ALL
Q108	J707386P1	TSTR BCW 32	ALL
Q201	J707387P1	TSTR BCW 30	ALL
Q202	J707435P1	TSTR BC 369	ALL
Q203	J707386P1	TSTR BCW 32	ALL
Q204	J707432P1	TSTR BCX 18	ALL
Q205	J707387P1	TSTR BCW 30	ALL
Q206	J707387P1	TSTR BCW 30	ALL
Q301	J707386P1	TSTR BCW 32	ALL
Q302	J707771P1	TSTR BFR 93	ALL
Q303	J707770P1	FLD EFF BF 4416A	ALL
Q401	J707433P1	FLD EFF BF 989	ALL
Q402	J707387P1	TSTR BCW 30	ALL
Q501	J707817P1	FLD EFF J309	ALL
Q502	J707817P1	FLD EFF J309	ALL
Q503	J707430P1	TSTR BF 569	ALL
Q504	J707387P1	TSTR BCW 30	ALL
Q505	J707419P1	TSTR JFET SI BF 511	ALL
Q506	J707430P1	TSTR BF 569	ALL
R101	J707385P470	RES MFILM 47 OHM 0,125W	ALL
R102	J707385P332	RES MFILM 3,3K OHM 0,125W	ALL
R103	J707385P152	RES MFILM 1,5K OHM 0,125W	ALL
R104	J707385P270	RES MFILM 27 OHM 0,125W	ALL
R105	J707385P332	RES MFILM 3,3K OHM 0,125W	ALL
R106	J707385P152	RES MFILM 1,5K OHM 0,125W	ALL
R107	J707385P331	RES MFILM 330 OHM 0,125W	ALL
R108	J707385P100	RES MFILM 10 OHM 0,125W	ALL
R109	J707385P101	RES MFILM 100 OHM 0,125W	ALL
R110	J707385P562	RES MFILM 5,6K OHM 0,125W	ALL
R111	J707385P680	RES MFILM 68 OHM 0,125W	ALL
R112	J707385P102	RES MFILM 1K OHM 0,125W	ALL
R113	J707385P472	RES MFILM 4,7K OHM 0,125W	ALL
R114	J707385P152	RES MFILM 1,5K OHM 0,125W	ALL
R115	J707478P4	RES VAR 1K OHM 0,05W	ALL
R116	J707385P102	RES MFILM 1K OHM 0,125W	ALL
R117	J707385P270	RES MFILM 27 OHM 0,125W	ALL
R118	J707385P102	RES MFILM 1K OHM 0,125W	ALL
R119	J707385P270	RES MFILM 27 OHM 0,125W	ALL
R120	J707385P100	RES MFILM 10 OHM 0,125W	ALL
R121	J707385P100	RES MFILM 10 OHM 0,125W	ALL
R122	J707385P221	RES MFILM 220 OHM 0,125W	ALL
R123	J707385P473	RES MFILM 47K OHM 0,125W	ALL
R124	J707385P100	RES MFILM 10 OHM 0,125W	ALL
R125	J707385P102	RES MFILM 1K OHM 0,125W	ALL
R126	J707945P1	RES WW 0,27 OHM	ALL
R201	J707385P272	RES MFILM 2,7K OHM 0,125W	ALL
R202	J707385P222	RES MFILM 2,2K OHM 0,125W	ALL
R203	J707385P153	RES MFILM 15K OHM 0,125W	ALL
R204	J707385P102	RES MFILM 1K OHM 0,125W	ALL
R205	J707385P101	RES MFILM 100 OHM 0,125W	ALL
R206	J707385P273	RES MFILM 27K OHM 0,125W	ALL
R207	J707385P682	RES MFILM 6,8K OHM 0,125W	ALL

CIRCUIT POSITION	COMPONENT ITEM NUMBER	COMPONENT DESCRIPTION	WHERE APPLIED
R209	J707385P393	RES MFILM 39K OHM 0,125W	ALL
R210	J707385P333	RES MFILM 33K OHM 0,125W	ALL
R211	J707385P103	RES MFILM 10K OHM 0,125W	ALL
R212	J707385P182	RES MFILM 1,8K OHM 0,125W	ALL
R213	J707385P473	RES MFILM 47K OHM 0,125W	ALL
R214	J707385P153	RES MFILM 15K OHM 0,125W	ALL
R215	J707385P473	RES MFILM 47K OHM 0,125W	ALL
R216	J707385P153	RES MFILM 15K OHM 0,125W	ALL
R301	J707385P562	RES MFILM 5,6K OHM 0,125W	ALL
R302	J707385P102	RES MFILM 1K OHM 0,125W	ALL
R303	J707385P473	RES MFILM 47K OHM 0,125W	ALL
R304	J707385P472	RES MFILM 4,7K OHM 0,125W	ALL
R305	J707385P103	RES MFILM 10K OHM 0,125W	ALL
R306	J707385P682	RES MFILM 6,8K OHM 0,125W	ALL
R307	J707385P391	RES MFILM 390 OHM 0,125W	ALL
R308	J707385P561	RES MFILM 560 OHM 0,125W	ALL
R309	J707385P470	RES MFILM 47 OHM 0,125W	ALL
R310	J707385P470	RES MFILM 47 OHM 0,125W	ALL
R311	J707385P182	RES MFILM 1,8K OHM 0,125W	ALL
R312	J707385P101	RES MFILM 100 OHM 0,125W	ALL
R401	J707385P152	RES MFILM 1,5K OHM 0,125W	ALL
R402	J707385P473	RES MFILM 47K OHM 0,125W	ALL
R403	J707385P473	RES MFILM 47K OHM 0,125W	ALL
R404	J707385P561	RES MFILM 560 OHM 0,125W	ALL
R405	J707385P103	RES MFILM 10K OHM 0,125W	ALL
R406	J707385P332	RES MFILM 3,3K OHM 0,125W	ALL
R407	J707385P683	RES MFILM 68K OHM 0,125W	ALL
R408	J707385P473	RES MFILM 47K OHM 0,125W	ALL
R409	J707478P10	RES VAR 10K OHM 0,05W	ALL
R411	J707385P272	RES MFILM 2,7K OHM 0,125W	ALL
R412	J707385P563	RES MFILM 56K OHM 0,125W	ALL
R413	J707385P273	RES MFILM 27K OHM 0,125W	ALL
R414	J707385P683	RES MFILM 68K OHM 0,125W	ALL
R415	J707385P182	RES MFILM 1,8K OHM 0,125W	ALL
R416	J707385P473	RES MFILM 47K OHM 0,125W	ALL
R417	J707385P183	RES MFILM 18K OHM 0,125W	ALL
R418	J707385P334	RES MFILM 330K OHM 0,125W	ALL
R419	J707385P473	RES MFILM 47K OHM 0,125W	ALL
R420	J707478P11	RES VAR 15K OHM 0,05W	ALL
R421	J707385P473	RES MFILM 47K OHM 0,125W	ALL
R422	J707385P101	RES MFILM 100 OHM 0,125W	ALL
R423	J707385P470	RES MFILM 47 OHM 0,125W	ALL
R424	J707385P470	RES MFILM 47 OHM 0,125W	ALL
R501	J707385P101	RES MFILM 100 OHM 0,125W	ALL
R502	J707385P181	RES MFILM 180 OHM 0,125W	ALL
R503	J707385P470	RES MFILM 47 OHM 0,125W	ALL
R505	J707385P181	RES MFILM 180 OHM 0,125W	ALL
R506	J707385P121	RES MFILM 120 OHM 0,125W	ALL
R507	J707385P121	RES MFILM 120 OHM 0,125W	ALL
R508	J707385P222	RES MFILM 2,2K OHM 0,125W	ALL
R509	J707385P222	RES MFILM 2,2K OHM 0,125W	ALL
R510	J707385P561	RES MFILM 560 OHM 0,125W	ALL
R511	J707385P472	RES MFILM 4,7K OHM 0,125W	ALL
R512	J707385P221	RES MFILM 220 OHM 0,125W	ALL
R513	J707385P103	RES MFILM 10K OHM 0,125W	ALL
R514	J707385P223	RES MFILM 22K OHM 0,125W	ALL
R516	J707385P183	RES MFILM 18K OHM 0,125W	ALL

CIRCUIT POSITION	COMPONENT ITEM NUMBER	COMPONENT DESCRIPTION	WHERE APPLIED
R517	J707385P100	RES MFILM 10 OHM 0,125W	ALL
R518	J707385P562	RES MFILM 5,6K OHM 0,125W	ALL
R519	J707385P104	RES MFILM 100K OHM 0,125W	ALL
R520	J707406P1	RES NTC 330 OHM	M905468G1 /-G2
R521	J707385P470	RES MFILM 47 OHM 0,125W	ALL
R522	J707385P273	RES MFILM 27K OHM 0,125W.	ALL
R523	J707385P472	RES MFILM 4,7K OHM 0,125W	ALL
R524	J707385P334	RES MFILM 330K OHM 0,125W	ALL
R525	J707385P222	RES MFILM 2,2K OHM 0,125W	ALL
R526	J707385P392	RES MFILM 3,9K OHM 0,125W	ALL
R527	J707385P273	RES MFILM 27K OHM 0,125W	ALL
R528	J707385P101	RES MFILM 100 OHM 0,125W	ALL
R529	J707385P102	RES MFILM 1K OHM 0,125W	ALL
R530	J707385P101	RES MFILM 100 OHM 0,125W	ALL
R531	J707385P103	RES MFILM 10K OHM 0,125W	ALL
R533	J707385P153	RES MFILM 15K OHM 0,125W	ALL
R534	J707385P184	RES MFILM 180K OHM 0,125W	ALL
R536	J707385P100	RES MFILM 10 OHM 0,125W	ALL
R537	J707385P152	RES MFILM 1,5K OHM 0,125W	ALL
R538	J707385P221	RES MFILM 220 OHM 0,125W	ALL
R539	J707385P184	RES MFILM 180K OHM 0,125W	ALL
U401	J707449P1	INT CKT MC3357	ALL
U402	M905492G1	INT CKT SQ4001 SQUELCH-UN.	ALL
U501	J707434P2	INT CKT 4053/S016	ALL
U502	J707337P1	INT CKT , MC145146	ALL
U503	J707374P2	INT CKT SP8718	ALL
U504	L855471G1	INT CKT. RES. NETW.	M905468G3 /-G4
W501	A700134P9	WIRE , JMPR	M905468G1 /-G2
Y501	J707019P3	X-TAL 6,4MHZ 5PPM	ALL

ITEM NUMBER                      DESCRIPTION  
J707801G1                      RF 4662H , 25 KHZ CHANN. SPACING

-----  
P A R T S   L I S T :

CIRCUIT POSITION	COMPONENT ITEM NUMBER	COMPONENT DESCRIPTION	QUANTITY TOTAL
0002	J706804P2	WASH, INSULATION	2
Z401	J707310P1	FLT 21,4MHZ	1
Z403	J707446P1	FLT 455KHZ	1
A001	M905468G1	CPNT BD RF4660H	1

ITEM NUMBER                      DESCRIPTION  
J707801G4                      RF 4662L , 25 KHZ CHANN. SPACING

-----  
P A R T S   L I S T :

CIRCUIT POSITION	COMPONENT ITEM NUMBER	COMPONENT DESCRIPTION	QUANTITY TOTAL
0002	J706804P2	WASH, INSULATION	2
Z401	J707310P1	FLT 21,4MHZ	1
Z403	J707446P1	FLT 455KHZ	1
A001	M905468G2	CPNT BD RF4660L	1

ITEM NUMBER	DESCRIPTION
J707801G2	RF 4663H , 20 KHZ CHANN. SPACING

-----  
P A R T S L I S T :

CIRCUIT POSITION	COMPONENT ITEM NUMBER	COMPONENT DESCRIPTION	QUANTITY TOTAL
0002	J706804P2	WASH,INSULATION	2
Z401	J707310P2	FLT 21,4MHZ	1
Z403	J707446P3	FLT 455KHZ	1
A001	M905468G1	CPNT BD RF4660H	1



ITEM NUMBER	DESCRIPTION
J707801G5	RF 4663L , 20 KHZ CHANN. SPACING

-----  
P A R T S L I S T :

CIRCUIT POSITION	COMPONENT ITEM NUMBER	COMPONENT DESCRIPTION	QUANTITY TOTAL
0002	J706804P2	WASH, INSULATION	2
Z401	J707310P2	FLT 21,4MHZ	1
Z403	J707446P3	FLT 455KHZ	1
A001	M905468G2	CPNT BD RF4660L	1

ITEM NUMBER	DESCRIPTION
J707801G5	RF 4663L , 20 KHZ CHANN. SPACING

-----  
P A R T S L I S T :

CIRCUIT POSITION	COMPONENT ITEM NUMBER	COMPONENT DESCRIPTION	QUANTITY TOTAL
0002	J706804P2	WASH, INSULATION	2
Z401	J707310P2	FLT 21,4MHZ	1
Z403	J707446P3	FLT 455KHZ	1
A001	M905468G2	CPNT BD RF4660L	1

ITEM NUMBER	DESCRIPTION
J707801G3	RF4664H , 12,5 KHZ CHANN. SPACING

-----  
P A R T S L I S T :

CIRCUIT POSITION	COMPONENT ITEM NUMBER	COMPONENT DESCRIPTION	QUANTITY TOTAL
0002	J706804P2	WASH INS	2
Z401	J707310P3	FLT 21,4MHZ	1
Z402	J707446P4	FLT 455KHZ	1
A001	M905468G3	CPNT BD. RF4660H, 3PPM STAB.	1

ITEM NUMBER	DESCRIPTION
J707801G6	RF4664L , 12.5 KHZ CHANN. SPACING.

-----  
P A R T S   L I S T :

CIRCUIT POSITION	COMPONENT ITEM NUMBER	COMPONENT DESCRIPTION	QUANTITY TOTAL
0002	J706804P2	WASH. INS.	2
Z401	J707310P3	FLT 21,4 MHZ	1
Z402	J707446P4	FLT 455 KHZ	1
A001	M905468G4	CPNT BD. RF4660L , 3PPM STAB.	1

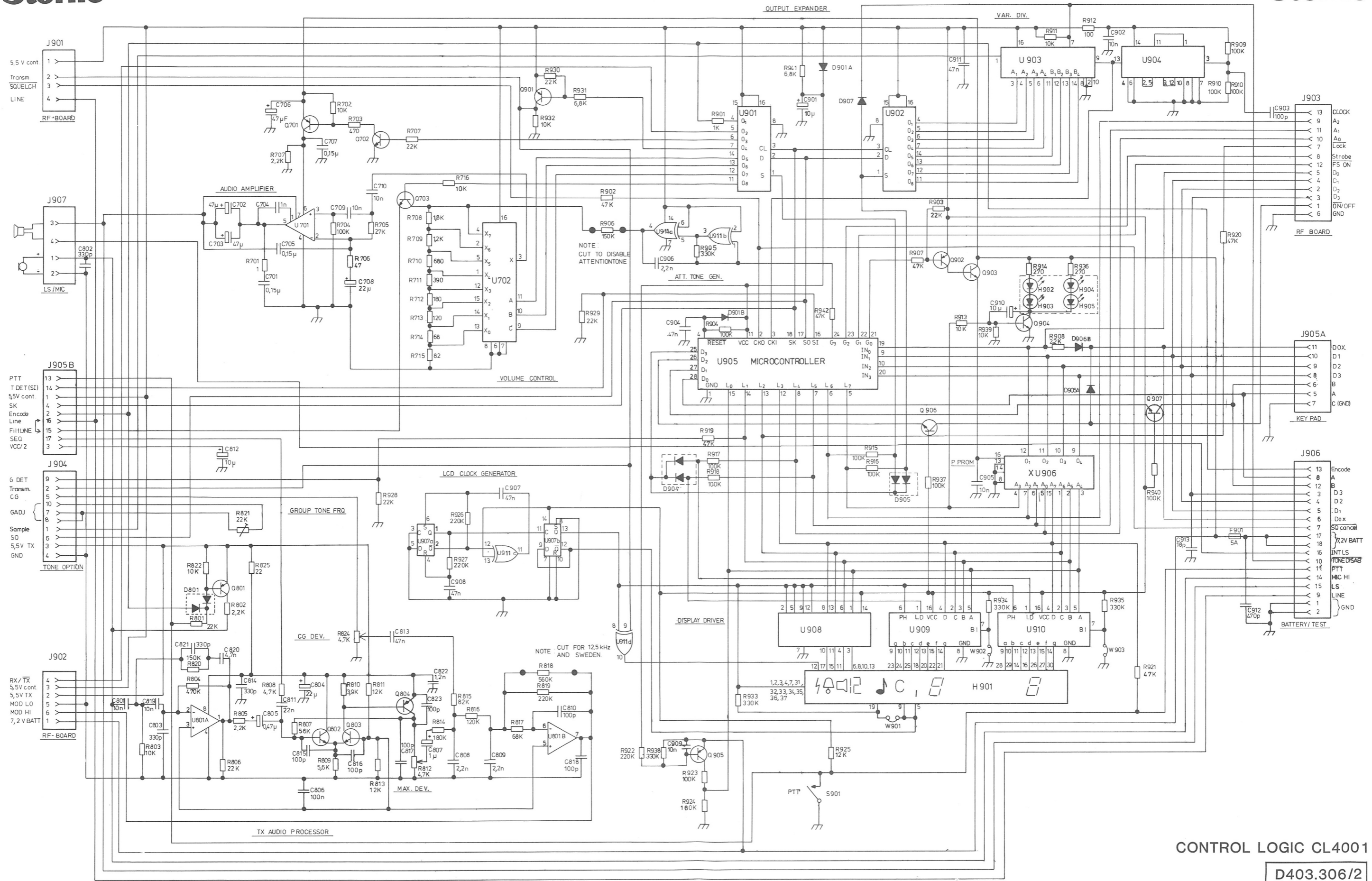

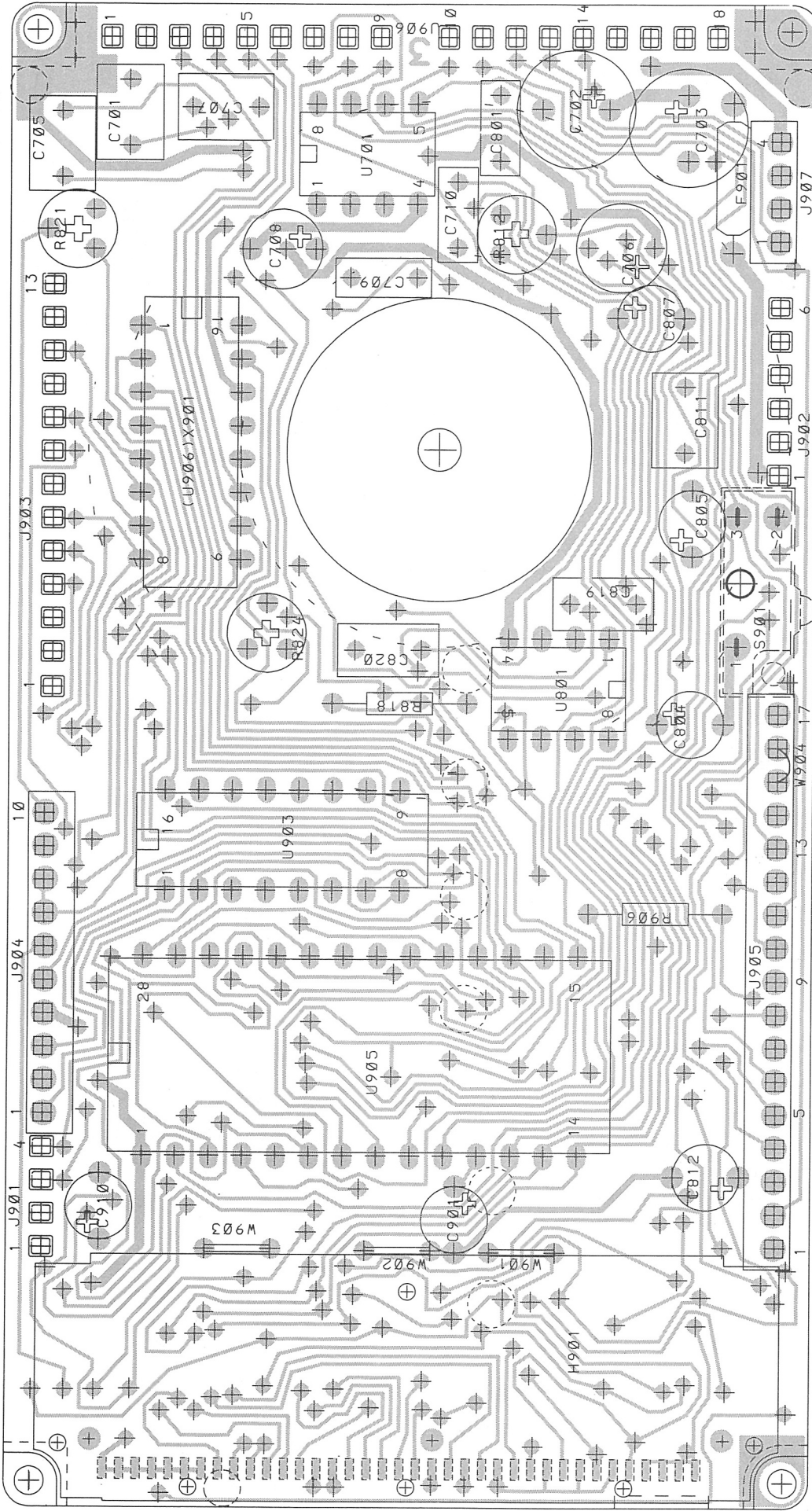

CONTROL LOGIC CL 4001  
COMPONENT LAY-OUT  
COMPONENT SIDE

CODE NO. M905465G1

D403. 311/2

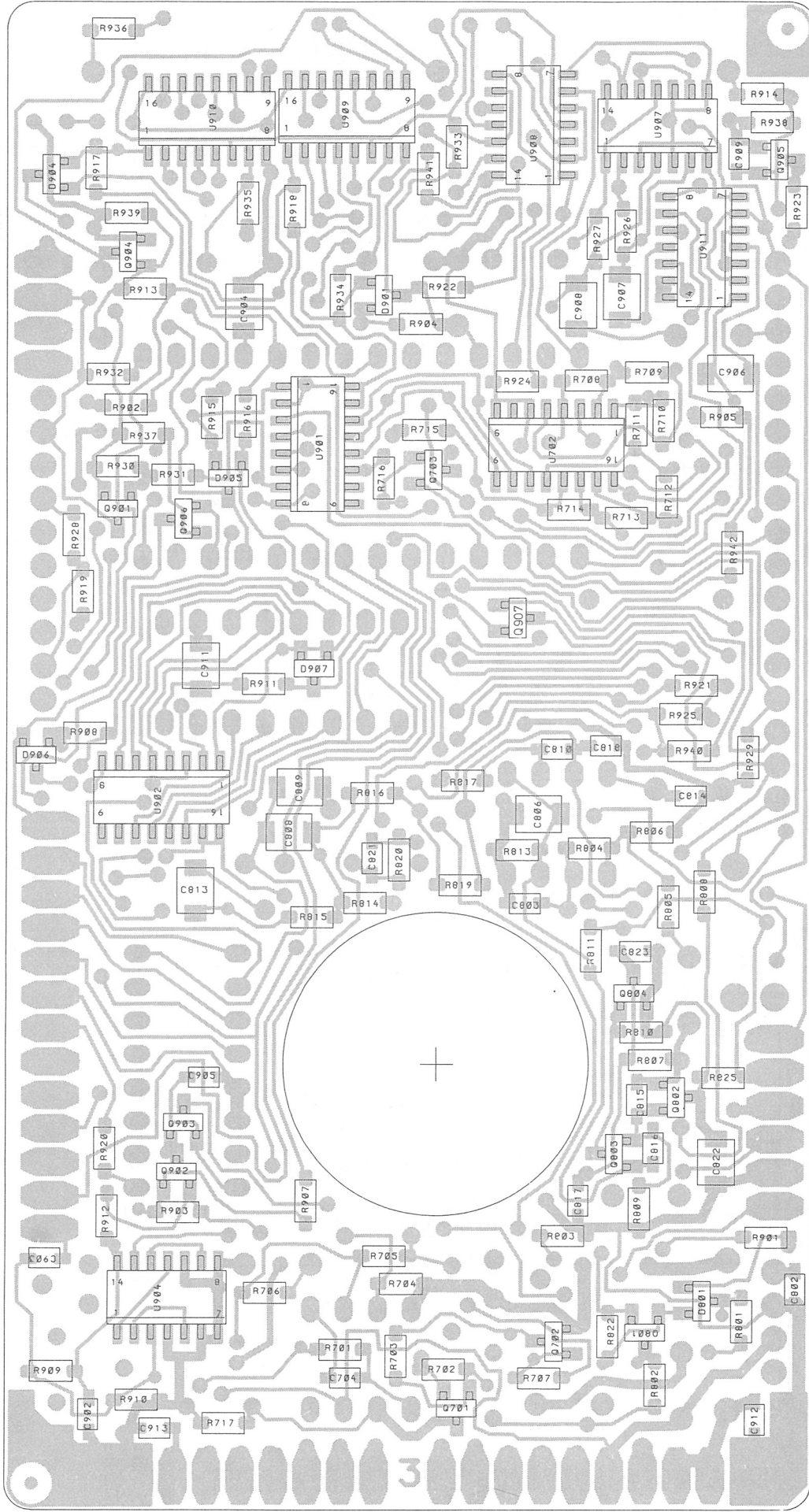

CONTROL LOGIC CL 4001  
COMPONENT LAYOUT  
CHIP SIDE

D403.312/2

CODE NO. M905465G1

ITEM NUMBER	DESCRIPTION
K805331G1	CONTROL LOGIC CL4001 , COMPLETE

M905465G1	SUB ASM - CL4001 CPNT BD
-----------	--------------------------

## P A R T S L I S T :

CIRCUIT POSITION	COMPONENT ITEM NUMBER	COMPONENT DESCRIPTION	QUANTITY
DISPLAY AND DISPLAY MECHANICS :			
S901	J707133P3	SWITCH	1
H901	J707230P1	DISPLAY, LCD	1
0005	K805332G1	ASM LIGHTENING DISPLAY	1
H902 - H905	J706022P1	DIODE LED, HP 5082-4190	4
	J707469P1	LEAD FRAME	1
	L855333P1	PLATE, ACRYLIC	1
0006	J707458P1	CONTACT STRAND SILC RUBB	1
0003	L855331P1	HOUSING FOR DISPLAY	1
0004	L855332P1	COVER FOR DISPLAY	1
COMPONENT BOARD CL4001 :			
X901	J706356P4	SOC 16PIN	1
J901-903, J906	J706434P2	CONN BUTTOM ENTRY	41
U904	J707242P1	INT CKT 4013/S014	1
U907	J707242P2	INT CKT 4013/S014	1
U901, U902	J707243P1	INT CKT 4094/S016	2
U909, U910	J707264P1	INT CKT 4543/S016	2
U903	J707322P1	INT CKT 14569	1
C807	J707353P4	CAP ELEC 1.0 UF 50V	1
C812, C901	J707353P7	CAP ELEC 10 UF 16V	2
C910	J707353P7	CAP ELEC 10 UF 16V	1
C706	J707353P9	CAP ELEC 47 UF 16V	1
R912	J707385P101	RES MFILM 100 OHM 0,125W	1
R901, R931	J707385P102	RES MFILM 1K OHM 0,125W	2
R702, R716	J707385P103	RES MFILM 10K OHM 0,125W	2
R803, R822	J707385P103	RES MFILM 10K OHM 0,125W	2
R911, R913	J707385P103	RES MFILM 10K OHM 0,125W	2
R932, R939	J707385P103	RES MFILM 10K OHM 0,125W	2
R704, R904	J707385P104	RES MFILM 100K OHM 0,125W	2
R909, R910	J707385P104	RES MFILM 100K OHM 0,125W	2
R915, R916	J707385P104	RES MFILM 100K OHM 0,125W	2
R917, R918	J707385P104	RES MFILM 100K OHM 0,125W	2
R923, R937	J707385P104	RES MFILM 100K OHM 0,125W	2
R713	J707385P121	RES MFILM 120 OHM 0,125W	1
R709	J707385P122	RES MFILM 1,2K OHM 0,125W	1
R811, R813	J707385P123	RES MFILM 12K OHM 0,125W	2
R923	J707385P123	RES MFILM 12K OHM 0,125W	1
R816	J707385P124	RES MFILM 120K OHM 0,125W	1
R820	J707385P154	RES MFILM 150K OHM 0,125W	1
R712	J707385P181	RES MFILM 180 OHM 0,125W	1
R708	J707385P182	RES MFILM 1,8K OHM 0,125W	1
R814, R924	J707385P184	RES MFILM 180K OHM 0,125W	2
R825	J707385P220	RES MFILM 22 OHM 0,125W	1
R717, R802	J707385P222	RES MFILM 2,2K OHM 0,125W	2
R805, R908	J707385P222	RES MFILM 2,2K OHM 0,125W	2
R707, R801	J707385P223	RES MFILM 22K OHM 0,125W	2
R806, R903	J707385P223	RES MFILM 22K OHM 0,125W	2
R928, R929	J707385P223	RES MFILM 22K OHM 0,125W	2
R930	J707385P223	RES MFILM 22K OHM 0,125W	1
R819, R922	J707385P224	RES MFILM 220K OHM 0,125W	2



CIRCUIT POSITION	COMPONENT ITEM NUMBER	COMPONENT DESCRIPTION	QUANTITY
R926, R927	J707385P224	RES MFILM 220K OHM 0,125W	2
R914, R936	J707385P271	RES MFILM 270 OHM 0,125W	2
R705	J707385P273	RES MFILM 27K OHM 0,125W	1
R905, R933	J707385P334	RES MFILM 330K OHM 0,125W	2
R934, R935	J707385P334	RES MFILM 330K OHM 0,125W	2
R938	J707385P334	RES MFILM 330K OHM 0,125W	1
R711	J707385P391	RES MFILM 390 OHM 0,125W	1
R810	J707385P392	RES MFILM 3,9K OHM 0,125W	1
R706	J707385P470	RES MFILM 47 OHM 0,125W	1
R703	J707385P471	RES MFILM 470 OHM 0,125W	1
R808	J707385P472	RES MFILM 4,7K OHM 0,125W	1
R902, R907	J707385P473	RES MFILM 47K OHM 0,125W	2
R919, R920	J707385P473	RES MFILM 47K OHM 0,125W	2
R921	J707385P473	RES MFILM 47K OHM 0,125W	1
R804	J707385P474	RES MFILM 470K OHM 0,125W	1
R809	J707385P562	RES MFILM 5,6K OHM 0,125W	1
R807	J707385P563	RES MFILM 56K OHM 0,125W	1
R714	J707385P680	RES MFILM 68 OHM 0,125W	1
R710	J707385P681	RES MFILM 680 OHM 0,125W	1
R817	J707385P683	RES MFILM 68K OHM 0,125W	1
R715	J707385P820	RES MFILM 82 OHM 0,125W	1
R815	J707385P823	RES MFILM 82K OHM 0,125W	1
R701	J707385P910	RES MFILM 91 OHM 0,125W	1
Q702, Q703	J707386P1	TSTR BCW 32	2
Q802, Q803	J707386P1	TSTR BCW 32	2
Q904, Q906	J707386P1	TSTR BCW 32	2
Q907	J707386P1	TSTR BCW 32	1
Q801, Q804	J707387P1	TSTR BCW 30	2
Q902, Q905	J707387P1	TSTR BCW 30	2
D801, D901	J707390P1	DIO SI BAV 70	2
D904, D905	J707390P1	DIO SI BAV 70	2
D906, D907	J707390P1	DIO SI BAV 70	2
C801	J707412P1	CAP POL 4,7NF 63V	1
C701, C705	J707412P10	CAP POL 0,15 UF 63V	2
C707,	J707412P10	CAP POL 0,15 UF 63V	1
C811	J707412P11	CAP POL 0,22 UF	1
C709, C710	J707412P3	CAP POL 10NF 63V	2
	J707412P5	CAP POL 0,022 UF 63V	1
Q903	J707429P1	TSTR BCX 20	1
Q701	J707432P1	TSTR BCX18	2
U702	J707434P1	INT CKT 4051/S016	1
C913	J707436P25	CAP CER 18PF 50V	1
C810, C815	J707436P61	CAP CER 100PF 50V	2
C816, C817	J707436P61	CAP CER 100PF 50V	2
C819, C903	J707436P61	CAP CER 100PF 50V	2
C803	J707436P73	CAP CER 330PF 50V	1
C814	J707436P73	CAP CER 330PF 50V	1
C808, C809	J707436P93	CAP CER 2,2NF 50V	2
C906	J707436P93	CAP CER 2,2NF 50V	1
C902, C905	J707438P14	CAP CER 10NF 50V	2
C909	J707438P14	CAP CER 10NF 50V	1
C806, C813	J707438P22	CAP CER 47NF 50V	2
C904, C907	J707438P22	CAP CER 47NF 50V	2
C908	J707438P22	CAP CER 47NF 50V	1
C911	J707438P22	CAP CER 47NF 50V	1

CIRCUIT POSITION	COMPONENT ITEM NUMBER	COMPONENT DESCRIPTION	QUANTITY
C912	J707438P3	CAP CER 470NF 50V	1
C704	J707438P5	CAP CER 1NF 50V	1
J907	J707442P1	CONN 4-POS FEMALE	1
J904	J707442P2	CONN 10-POS FEMALE	1
J905	J707442P3	CONN 17-POS FEMALE	1
C702, C703	J707444P17	CAP TA 47 UF 10V	2
C805	J707444P3	CAP TA 0,47 UF 35V	1
C708, C804	J707444P8	CAP TA 22 UF 16V	2
U801	J707450P1	INT CKT LM358	1
U701	J707451P1	INT CKT TBA 820M	1
U908, U911	J707464P1	INT CKT 4070/S014	2
F901	J707468P11	FUSE 5A	1
R906	J707476P51	RES DEPOS 150K OHM	1
R818	J707476P58	RES DEPOS 560K OHM 0,1W	1
R821	J707478P12	RES VAR 22K OHM 0,05W	1
R812, R824	J707478P8	RES VAR 4,7K OHM 0,05W	2
U905	J708019P2	INT CKT COP324C, U-PG CTL	1

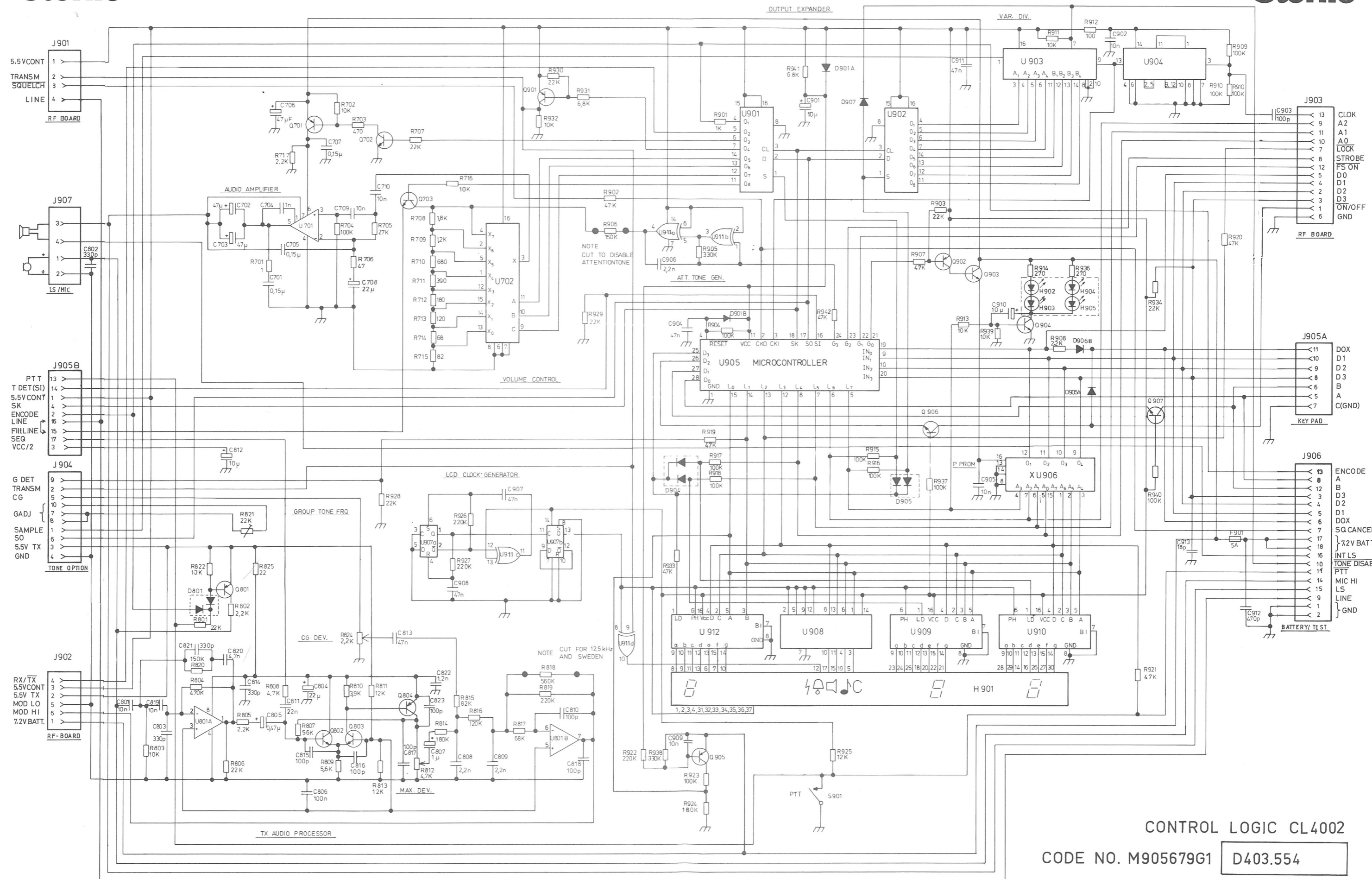

CONTROL LOGIC CL4002

CODE NO. M905679G1 D403.554



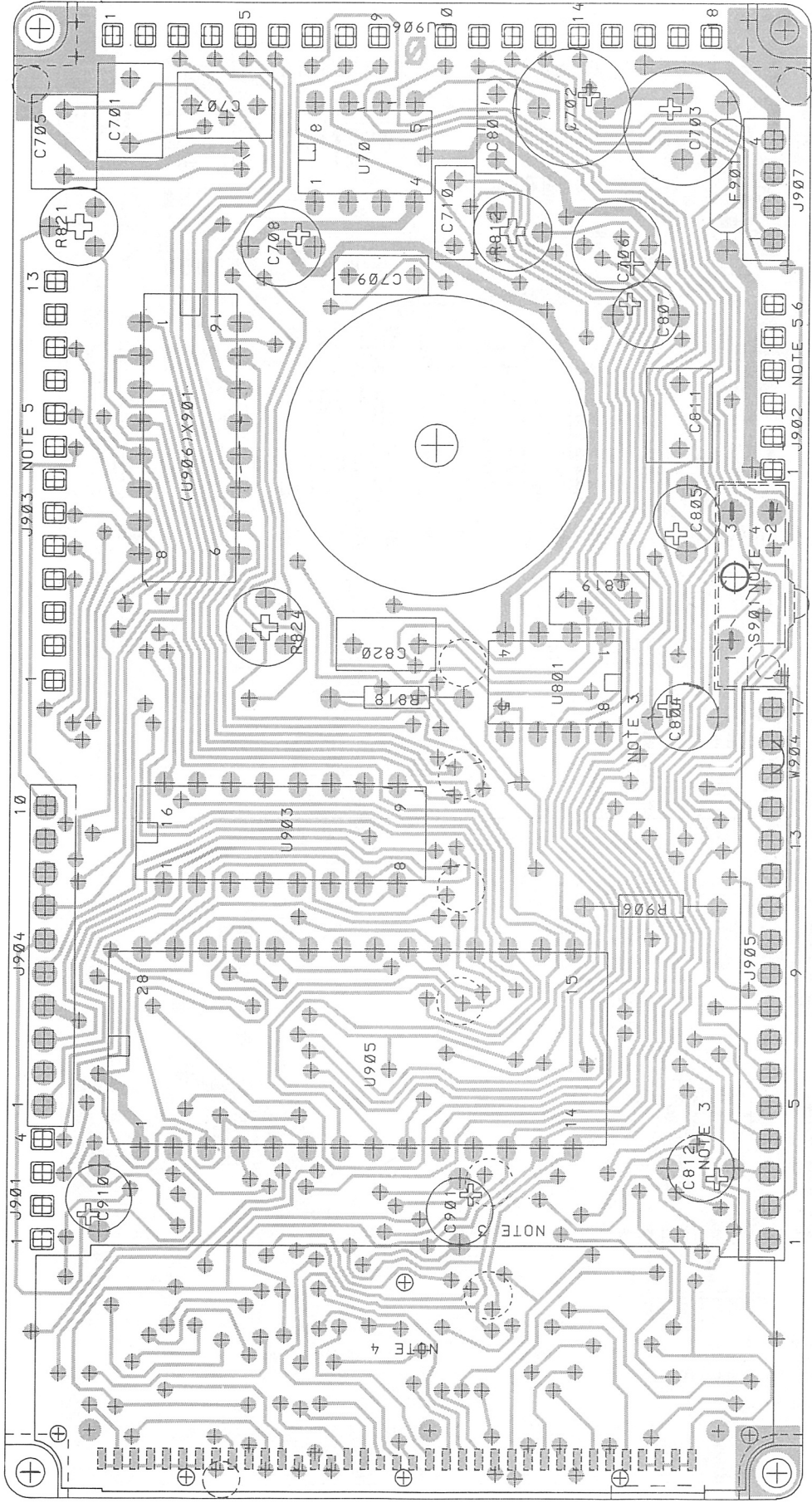

CONTROL LOGIC CL4002  
COMPONENT LAYOUT  
COMPONENT SIDE

CODE No. K805449G1      D403.512

ITEM NUMBER	DESCRIPTION
K805449G1	CL 4002 -10CH-
-----	
M905679G1	SUB ASM - CL4002 CPNT BD
-----	

## P A R T S L I S T :

CIRCUIT POSITION	COMPONENT ITEM NUMBER	COMPONENT DESCRIPTION	QUANTITY TOTAL
H901	J707230P1	DIS LT	1
S901	J707133P3	SW	1
C701	J707412P10	CAP POL 0,15MF 63V	1
C702	J707444P17	CAP TA 47MF 10V	1
C703	J707444P17	CAP TA 47MF 10V	1
C704	J707438P5	CAP CER 1NF 50V	1
C705	J707412P10	CAP POL 0,15MF 63V	1
C706	J707353P9	CAP ELEC 47MF 16V	1
C707	J707412P10	CAP POL 0,15MF 63V	1
C708	J707444P8	CAP TA 22MF 16V	1
C709	J707412P3	CAP POL 10NF 63V	1
C710	J707412P3	CAP POL 10NF 63V	1
C801	J707412P3	CAP POL 10NF 63V	1
C802	J707436P73	CAP CER 330PF 50V	1
C803	J707436P73	CAP CER 330PF 50V	1
C804	J707444P8	CAP TA 22MF 16V	1
C805	J707444P3	CAP TA 0,47MF 35V	1
C806	J707438P26	CAP CER 100NF 50V	1
C807	J707353P4	CAP ELEC 1MF 50V	1
C808	J707436P93	CAP CER 2,2NF 50V	1
C809	J707436P93	CAP CER 2,2NF 50V	1
C810	J707436P61	CAP CER 100PF 50V	1
C811	J707412P5	CAP POL 0,022MF 63V	1
C812	J707353P7	CAP ELEC 10MF 16V	1
C813	J707438P22	CAP CER 47NF 50V	1
C814	J707436P73	CAP CER 330PF 50V	1
C815	J707436P61	CAP CER 100PF 50V	1
C816	J707436P61	CAP CER 100PF 50V	1
C817	J707436P61	CAP CER 100PF 50V	1
C818	J707436P61	CAP CER 100PF 50V	1
C819	J707412P3	CAP POL 10NF 63V	1
C820	J707412P1	CAP POL 4,7NF 63V	1
C821	J707436P73	CAP CER 330PF 50V	1
C822	J707436P87	CAP CER 1,2NF 50V	1
C823	J707436P61	CAP CER 100PF 50V	1
C901	J707353P7	CAP ELEC 10MF 16V	1
C902	J707438P14	CAP CER 10NF 50V	1
C903	J707436P61	CAP CER 100PF 50V	1
C904	J707438P22	CAP CER 47NF 50V	1
C905	J707438P14	CAP CER 10NF 50V	1
C906	J707436P93	CAP CER 2,2NF 50V	1
C907	J707438P22	CAP CER 47NF 50V	1
C908	J707438P22	CAP CER 47NF 50V	1
C909	J707438P14	CAP CER 10NF 50V	1
C910	J707353P7	CAP ELEC 10MF 16V	1
C911	J707438P22	CAP CER 47NF 50V	1
C912	J707438P3	CAP CER 470PF 50V	1
C913	J707436P25	CAP CER 18PF 50V	1
D801	J707390P1	DIO SI BAV 70	1
D901	J707390P1	DIO SI BAV 70	1
D904	J707390P1	DIO SI BAV 70	1
D905	J707390P1	DIO SI BAV 70	1
D906	J707390P1	DIO SI BAV 70	1

CIRCUIT POSITION	COMPONENT ITEM NUMBER	COMPONENT DESCRIPTION	QUANTITY TOTAL
D907	J707390P1	DIO SI BAV 70	1
F901	J707468P11	FUSE 5A	1
J901	J706434P2	CONN BUTTOM ENTRY	4
J902	J706434P2	CONN BUTTOM ENTRY	6
J903	J706434P2	CONN BUTTOM ENTRY	3
J904	J707442P2	CONN 10-POS FEMALE	1
J905	J707442P3	CONN 17-POS FEMALE	1
J906	J706434P2	CONN BUTTOM ENTRY	8
J907	J707442P1	CONN 4-POS FEMALE	1
Q701	J707432P1	TSTR BCX18	1
Q702	J707386P1	TSTR BCW 32	1
Q703	J707386P1	TSTR BCW 32	1
Q801	J707387P1	TSTR BCW 30	1
Q802	J707386P1	TSTR BCW 32	1
Q803	J707386P1	TSTR BCW 32	1
Q804	J707387P1	TSTR BCW 30	1
Q901	J707432P1	TSTR BCX18	1
Q902	J707387P1	TSTR BCW 30	1
Q903	J707429P1	TSTR BCX 20	1
Q904	J707386P1	TSTR BCW 32	1
Q905	J707387P1	TSTR BCW 30	1
Q906	J707386P1	TSTR BCW 32	1
Q907	J707386P1	TSTR BCW 32	1
R701	J707385P910	RES MFILM 1 OHM 0,125W	1
R702	J707385P103	RES MFILM 10K OHM 0,125W	1
R703	J707385P471	RES MFILM 470 OHM 0,125W	1
R704	J707385P104	RES MFILM 100K OHM 0,125W	1
R705	J707385P273	RES MFILM 27K OHM 0,125W	1
R706	J707385P470	RES MFILM 47 OHM 0,125W	1
R707	J707385P223	RES MFILM 22K OHM 0,125W	1
R708	J707385P182	RES MFILM 1,8K OHM 0,125W	1
R709	J707385P122	RES MFILM 1,2K OHM 0,125W	1
R710	J707385P681	RES MFILM 680 OHM 0,125W	1
R711	J707385P391	RES MFILM 390 OHM 0,125W	1
R712	J707385P181	RES MFILM 180 OHM 0,125W	1
R713	J707385P121	RES MFILM 120 OHM 0,125W	1
R714	J707385P680	RES MFILM 68 OHM 0,125W	1
R715	J707385P820	RES MFILM 82 OHM 0,125W	1
R716	J707385P103	RES MFILM 10K OHM 0,125W	1
R717	J707385P222	RES MFILM 2,2K OHM 0,125W	1
R801	J707385P223	RES MFILM 22K OHM 0,125W	1
R802	J707385P222	RES MFILM 2,2K OHM 0,125W	1
R803	J707385P103	RES MFILM 10K OHM 0,125W	1
R804	J707385P474	RES MFILM 470K OHM 0,125W	1
R805	J707385P222	RES MFILM 2,2K OHM 0,125W	1
R806	J707385P223	RES MFILM 22K OHM 0,125W	1
R807	J707385P563	RES MFILM 56K OHM 0,125W	1
R808	J707385P472	RES MFILM 4,7K OHM 0,125W	1
R809	J707385P562	RES MFILM 5,6K OHM 0,125W	1
R810	J707385P392	RES MFILM 3,9K OHM 0,125W	1
R811	J707385P123	RES MFILM 12K OHM 0,125W	1
R812	J707478P8	RES VAR 4,7K OHM 0,05W	1
R813	J707385P123	RES MFILM 12K OHM 0,125W	1
R814	J707385P184	RES MFILM 180K OHM 0,125W	1
R815	J707385P823	RES MFILM 82K OHM 0,125W	1
R816	J707385P124	RES MFILM 120K OHM 0,125W	1
R817	J707385P683	RES MFILM 68K OHM 0,125W	1
R818	J707476P58	RES DEPOS 560K OHM 0,1W	1
R819	J707385P224	RES MFILM 220K OHM 0,125W	1
R820	J707385P154	RES MFILM 150K OHM 0,125W	1

CIRCUIT POSITION	COMPONENT ITEM NUMBER	COMPONENT DESCRIPTION	QUANTITY TOTAL
R821	J707478P12	RES VAR 22K OHM 0,05W	1
R822	J707385P103	RES MFILM 10K OHM 0,125W	1
R824	J707478P6	RES VAR 2,2K OHM 0,05W	1
R825	J707385P220	RES MFILM 22 OHM 0,125W	1
R901	J707385P102	RES MFILM 1K OHM 0,125W	1
R902	J707385P473	RES MFILM 47K OHM 0,125W	1
R903	J707385P223	RES MFILM 22K OHM 0,125W	1
R904	J707385P104	RES MFILM 100K OHM 0,125W	1
R905	J707385P334	RES MFILM 330K OHM 0,125W	1
R906	J707476P51	RES DEPOS 150K OHM	1
R907	J707385P473	RES MFILM 47K OHM 0,125W	1
R908	J707385P222	RES MFILM 2,2K OHM 0,125W	1
R909	J707385P104	RES MFILM 100K OHM 0,125W	1
R910	J707385P104	RES MFILM 100K OHM 0,125W	1
R911	J707385P103	RES MFILM 10K OHM 0,125W	1
R912	J707385P101	RES MFILM 100 OHM 0,125W	1
R913	J707385P103	RES MFILM 10K OHM 0,125W	1
R914	J707385P271	RES MFILM 270 OHM 0,125W	1
R915	J707385P104	RES MFILM 100K OHM 0,125W	1
R916	J707385P104	RES MFILM 100K OHM 0,125W	1
R917	J707385P104	RES MFILM 100K OHM 0,125W	1
R918	J707385P104	RES MFILM 100K OHM 0,125W	1
R919	J707385P473	RES MFILM 47K OHM 0,125W	1
R920	J707385P473	RES MFILM 47K OHM 0,125W	1
R921	J707385P473	RES MFILM 47K OHM 0,125W	1
R922	J707385P224	RES MFILM 220K OHM 0,125W	1
R923	J707385P104	RES MFILM 100K OHM 0,125W	1
R924	J707385P184	RES MFILM 180K OHM 0,125W	1
R925	J707385P123	RES MFILM 12K OHM 0,125W	1
R926	J707385P224	RES MFILM 220K OHM 0,125W	1
R927	J707385P224	RES MFILM 220K OHM 0,125W	1
R928	J707385P223	RES MFILM 22K OHM 0,125W	1
R929	J707385P223	RES MFILM 22K OHM 0,125W	1
R930	J707385P223	RES MFILM 22K OHM 0,125W	1
R931	J707385P102	RES MFILM 1K OHM 0,125W	1
R932	J707385P103	RES MFILM 10K OHM 0,125W	1
R933	J707385P473	RES MFILM 47K OHM 0,125W	1
R934	J707385P223	RES MFILM 22K OHM 0,125W	1
R936	J707385P271	RES MFILM 270 OHM 0,125W	1
R937	J707385P104	RES MFILM 100K OHM 0,125W	1
R938	J707385P334	RES MFILM 330K OHM 0,125W	1
R939	J707385P103	RES MFILM 10K OHM 0,125W	1
R940	J707385P104	RES MFILM 100K OHM 0,125W	1
R941	J707385P682	RES MFILM 6,8K OHM 0,125W	1
R942	J707385P473	RES MFILM 47K OHM 0,125W	1
U701	J707451P1	INT CKT TBA 820M	1
U702	J707434P1	INT CKT 4051/S016	1
U801	J707450P1	INT CKT LM358	1
U901	J707243P1	INT CKT 4094/S016	1
U902	J707243P1	INT CKT 4094/S016	1
U903	J707322P1	INT CKT 14569	1
U904	J707242P2	INT CKT 4013/S014	1
U905	J708019P1	INT CKT COP324C	1
U907	J707242P1	INT CKT 4013/S014	1
U908	J707464P1	INT CKT 4070/S014	1
U909	J707264P1	INT CKT 4543/S016	1
U910	J707264P1	INT CKT 4543/S016	1
U911	J707464P1	INT CKT 4070/S014	1
U912	J707264P1	INT CKT 4543/S016	1
X901	J706356P4	SOC 16 PIN	1



CIRCUIT POSITION	COMPONENT ITEM NUMBER	COMPONENT DESCRIPTION	QUANTITY TOTAL
X902	J706331P7	SOC 28 PIN	1
0003	L855331P1	HSG DIS	1
0004	L855332P1	COV DIS	1
0005	K805332G1	DIS LT ASM	1
	J706022P1	DIO LT HP 5082-4190	4
	J707469P1	LEAD FRAME	3
	L855333P1	PLT, ACRYLIC	1
0006	J707458P1	CONT STR SIL	1

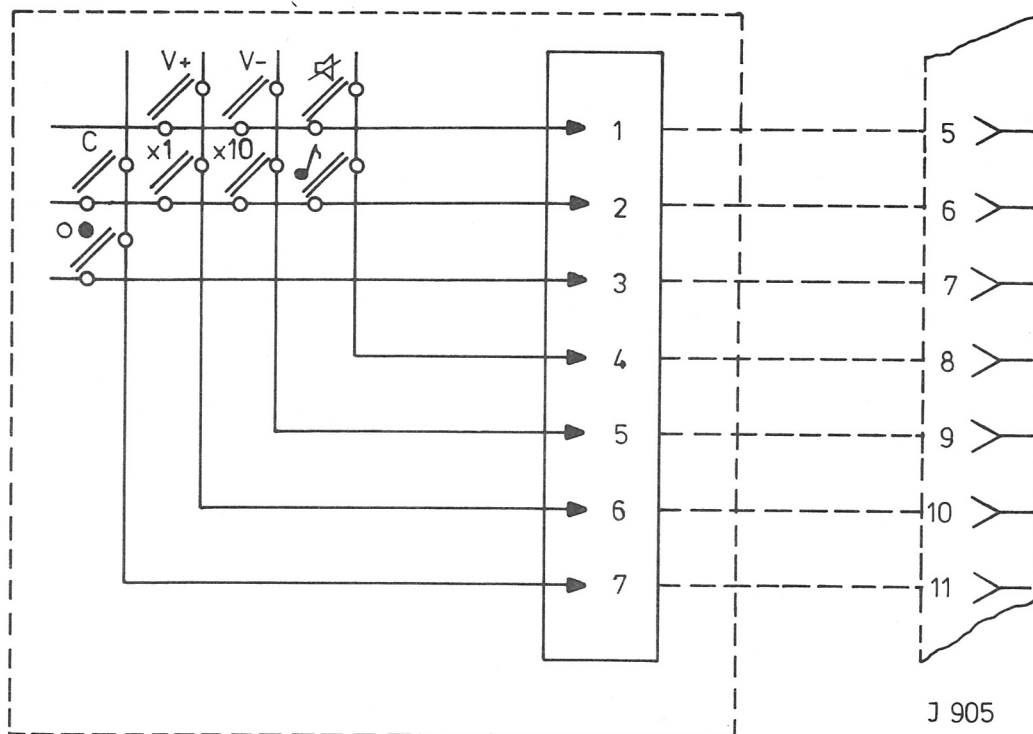

J 905  
(Part of CL 4001)

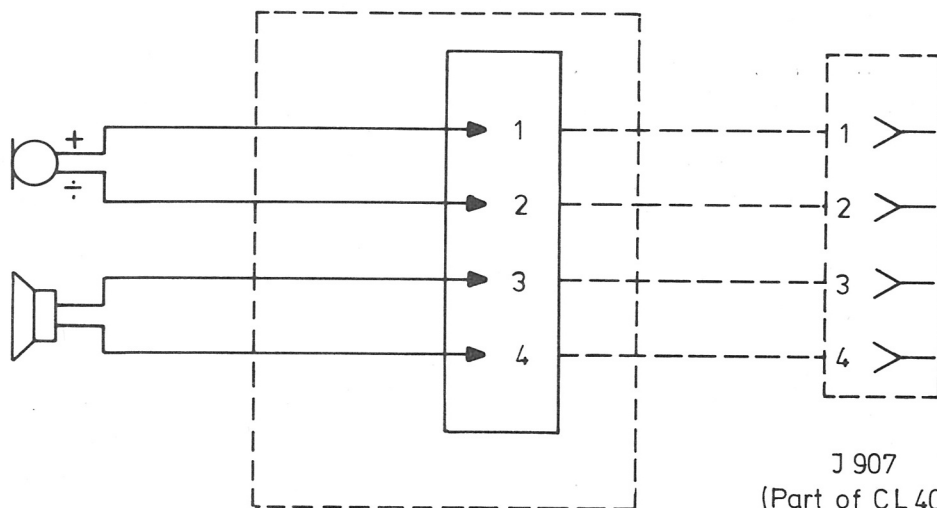

J 907  
(Part of CL 4001)

ITEM NUMBER	DESCRIPTION
L855355G1	CONTROL PANEL CP4001

-----  
P A R T S L I S T :

CIRCUIT POSITION	COMPONENT ITEM NUMBER	COMPONENT DESCRIPTION	QUANTITY TOTAL
	A700007P13	CAP CER NPO 10P 5% 50V	1
	A701301P2	MIKE	1
	J706863P1	FILTER	1
	J707235P1	GSKT,MIKE	1
	J707407P1	LS	1
	K805349G1	COV ASM	1
	K805301P1	LENS	1
	K805350G1	COV METALL ASM	1
	M905407P1	KEYBOARD OVERLAY	1
	L855350P1	LOCK RING	1
	L855396P1	CPNT BD FLEX	1
	M905459P1	GRL MLD	1

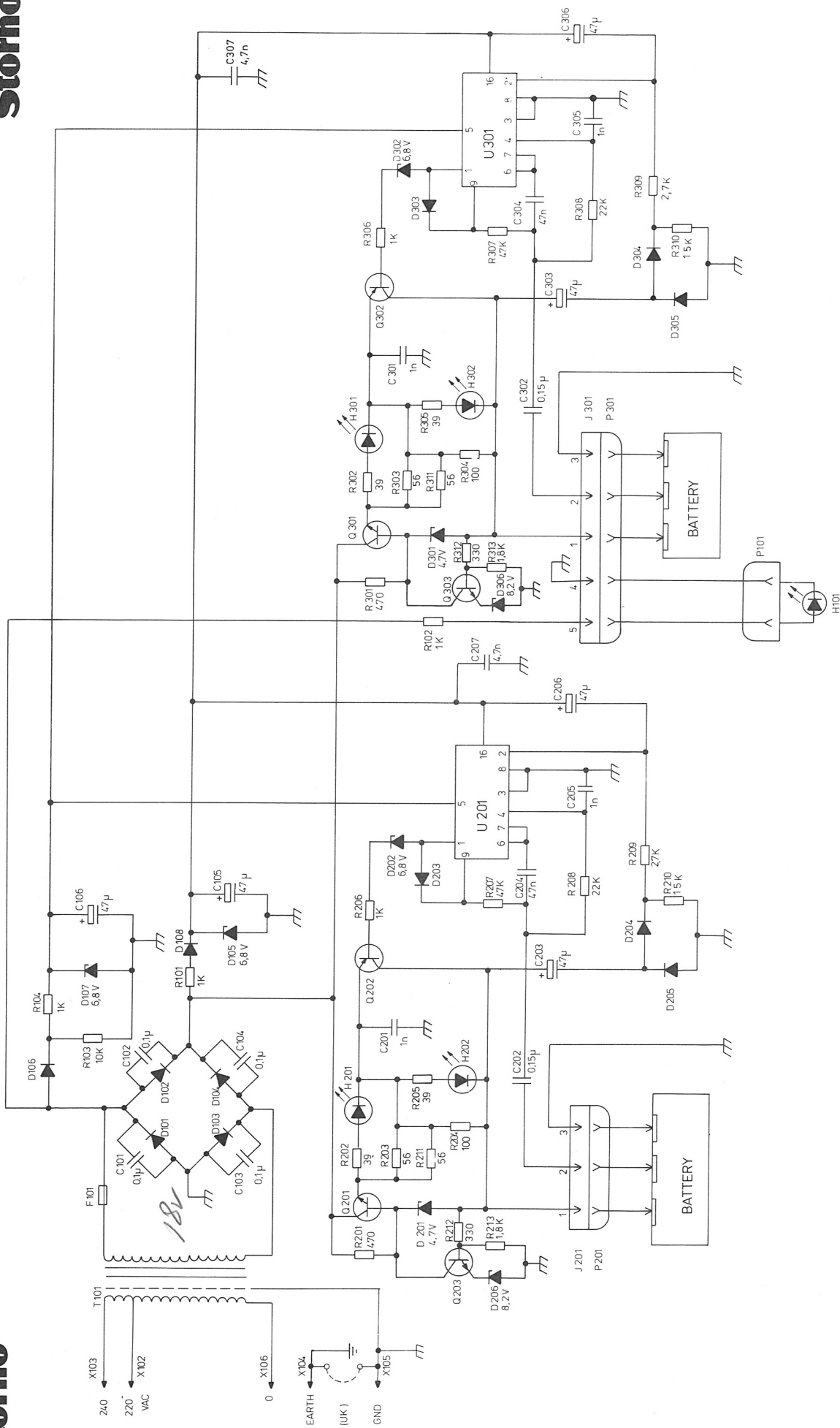

CHARGING UNIT CU4001

D403.293

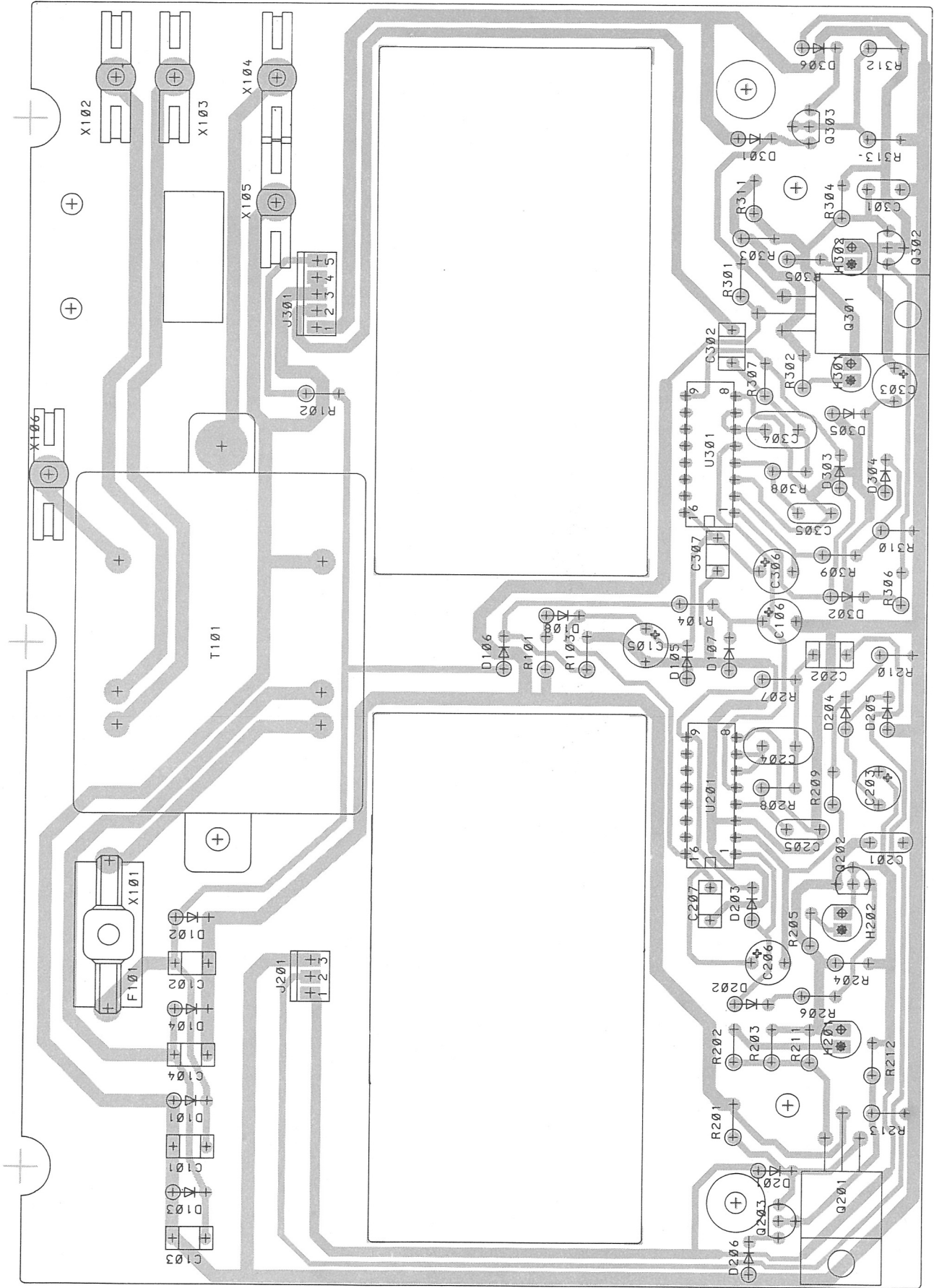

CHARGING UNIT CU4001  
COMPONENT LAYOUT

D403.310

ITEM NUMBER	DESCRIPTION
M905550G1	CU4001 , BATT CHARGER

M905427G1	SUB ASM : CPNT BD CU4001
-----------	--------------------------

## P A R T S L I S T :

CIRCUIT POSITION	COMPONENT ITEM NUMBER	COMPONENT DESCRIPTION	QUANTITY TOTAL
------------------	-----------------------	-----------------------	----------------

## MECHANICAL PARTS:

A700031P413	SCR M3X12	2
A700034P4	NUT HEX M3	2
A701312P4	WASH	2
J706076P5	WASH	6
J706212P205	SCREW	5
J706902P1	CLAMP	1
J706902P2	CLAMP	1
J707524G1	CORD PWR ASM CU4001	1
J706968P2	CORD PWR	1
K805335P1	GROMMET	1
J707525P1	LABEL, EUR	1
J707688P2	BUMPER	4
J707867P416	SCR	4
L855370G1	CABINET ASM CU4000	1
J706136P2	DIO OPTO	1
J706163P1	NAME PLT	1
J706212P205	SCREW	2
J706921P1	RET	1
J707527P1	WASH	2
K805333P1	GUIDE	4
K805336G1	CABLE-SLIDE BD	1
K805336G2	CABLE-SLIDE BD AND LED	1
K805356G1	CAB CHARGER DRILL	1
L855361P1	SPRING	2
L855365G1	SLIDE BD ASM CU4001	2
A701488P2	RING RETAINING	3
J707531P1	SPRING	3
K805339P1	CONTACT PIN	3
M905485P1	SLIDE BD	1
L855404G1	PLATE BOT PAINT	1

## COMPONENT BOARD:

U201	A700029P214	INT CKT TIMR 4521B	1
U301	A700029P214	INT CKT TIMR 4521B	1
Q201	A700054P1	TSTR NPN SI BD 201	1
Q301	A700054P1	TSTR NPN SI BD 201	1
J201	A700072P29	CONN PWB MALE 03 CKT	1
J301	A700072P31	CONN PWB MALE 05 CKT	1
C201	A700233P7	CAP CER 1NF 50V	1
C205	A700233P7	CAP CER 1NF 50V	1
C301	A700233P7	CAP CER 1NF 50V	1
C305	A700233P7	CAP CER 1NF 50V	1
C204	A702059P11	CAP PYES 47U 5% 50V	1
C304	A702059P11	CAP PYES 47U 5% 50V	1
R202	A702110P20	RES DEPC 39R 5% 1/4W	1
R205	A702110P20	RES DEPC 39R 5% 1/4W	1
R302	A702110P20	RES DEPC 39R 5% 1/4W	1
R305	A702110P20	RES DEPC 39R 5% 1/4W	1
R203	A702110P22	RES DEPC 56R 5% 1/4W	1
R211	A702110P22	RES DEPC 56R 5% 1/4W	1
R303	A702110P22	RES DEPC 56R 5% 1/4W	1

CIRCUIT POSITION	COMPONENT ITEM NUMBER	COMPONENT DESCRIPTION	QUANTITY
R311	A702110P22	RES DEPC 56R 5% 1/4W	1
R204	A702110P25	RES DEPC 100R 5% 1/4W	1
R304	A702110P25	RES DEPC 100R 5% 1/4W	1
R212	A702110P31	RES DEPC 330R 5% 1/4W	1
R312	A702110P31	RES DEPC 330R 5% 1/4W	1
R201	A702110P33	RES DEPC 470R 5% 1/4W	1
R301	A702110P33	RES DEPC 470R 5% 1/4W	1
R101	A702110P37	RES DEPC 1K0 5% 1/4W	1
R102	A702110P37	RES DEPC 1K0 5% 1/4W	1
R104	A702110P37	RES DEPC 1K0 5% 1/4W	1
R206	A702110P37	RES DEPC 1K0 5% 1/4W	1
R306	A702110P37	RES DEPC 1K0 5% 1/4W	1
R213	A702110P40	RES DEPC 1K8 5% 1/4W	1
R313	A702110P40	RES DEPC 1K8 5% 1/4W	1
R209	A702110P42	RES DEPC 2K7 5% 1/4W	1
R309	A702110P42	RES DEPC 2K7 5% 1/4W	1
R103	A702110P49	RES DEPC 10K 5% 1/4W	1
R210	A702110P51	RES DEPC 15K 5% 1/4W	1
R310	A702110P51	RES DEPC 15K 5% 1/4W	1
R208	A702110P53	RES DEPC 22K 5% 1/4W	1
R308	A702110P53	RES DEPC 22K 5% 1/4W	1
R207	A702110P57	RES DEPC 47K 5% 1/4W	1
R307	A702110P57	RES DEPC 47K 5% 1/4W	1
D101	J706100P1	DIO SI SIG 1N4001	1
D102	J706100P1	DIO SI SIG 1N4001	1
D103	J706100P1	DIO SI SIG 1N4001	1
D104	J706100P1	DIO SI SIG 1N4001	1
H201	J706136P3	DIO OPTO ELEC YELLOW	1
H301	J706136P3	DIO OPTO ELEC YELLOW	1
H202	J706136P4	DIO OPTO ELEC GREEN	1
H302	J706136P4	DIO OPTO ELEC GREEN	1
X101	J706903P1	FZ HLR	1
X102	J706904P1	TERM SLD RLN 2689002	1
X103	J706904P1	TERM SLD RLN 2689002	1
X104	J706904P1	TERM SLD RLN 2689002	1
X105	J706904P1	TERM SLD RLN 2689002	1
X106	J706904P1	TERM SLD RLN 2689002	1
F101	J706998P5	FUSE CTG 0.500A	1
C105	J707353P9	CAP ELEC 47 UF 16V	1
C106	J707353P9	CAP ELEC 47 UF 16V	1
C203	J707353P9	CAP ELEC 47 UF 16V	1
C206	J707353P9	CAP ELEC 47 UF 16V	1
C303	J707353P9	CAP ELEC 47 UF 16V	1
C306	J707353P9	CAP ELEC 47 UF 16V	1
C207	J707412P1	CAP PYES 4N7 10% 63V	1
C307	J707412P1	CAP PYES 4N7 10% 63V	1
C202	J707412P10	CAP PYES 150N 10% 63V	1
C302	J707412P10	CAP PYES 150N 10% 63V	1
C101	J707412P9	CAP PYES 100N 10% 63V	1
C102	J707412P9	CAP PYES 100N 10% 63V	1
C103	J707412P9	CAP PYES 100N 10% 63V	1
C104	J707412P9	CAP PYES 100N 10% 63V	1
Q202	J707435P1	TSTR PNP SI BC 369	1
Q302	J707435P1	TSTR PNP SI BC 369	1
	J707507P1	TRAFO	1
Q203	J707511P1	TSTR SI BC548	1

CIRCUIT POSITION	COMPONENT ITEM NUMBER	COMPONENT DESCRIPTION	QUANTITY
Q303	J707511P1	TSTR SI BC548	1
D106	J707513P1	DIO SI 1N4148	1
D108	J707513P1	DIO SI 1N4148	1
D203	J707513P1	DIO SI 1N4148	1
D204	J707513P1	DIO SI 1N4148	1
D205	J707513P1	DIO SI 1N4148	1
D303	J707513P1	DIO SI 1N4148	1
D304	J707513P1	DIO SI 1N4148	1
D305	J707513P1	DIO SI 1N4148	1
D201	J707514P1	DIO SI ZENR 4,7V	1
D301	J707514P1	DIO SI ZENR 4,7V	1
D105	J707514P4	DIO SI ZENR 6,8V	1
D107	J707514P4	DIO SI ZENR 6,8V	1
D202	J707514P4	DIO SI ZENR 6,8V	1
D302	J707514P4	DIO SI ZENR 6,8V	1
D206	J707514P5	DIO SI ZENR 8,2V	1
D306	J707514P5	DIO SI ZENR 8,2V	1



# Storno

# Storno

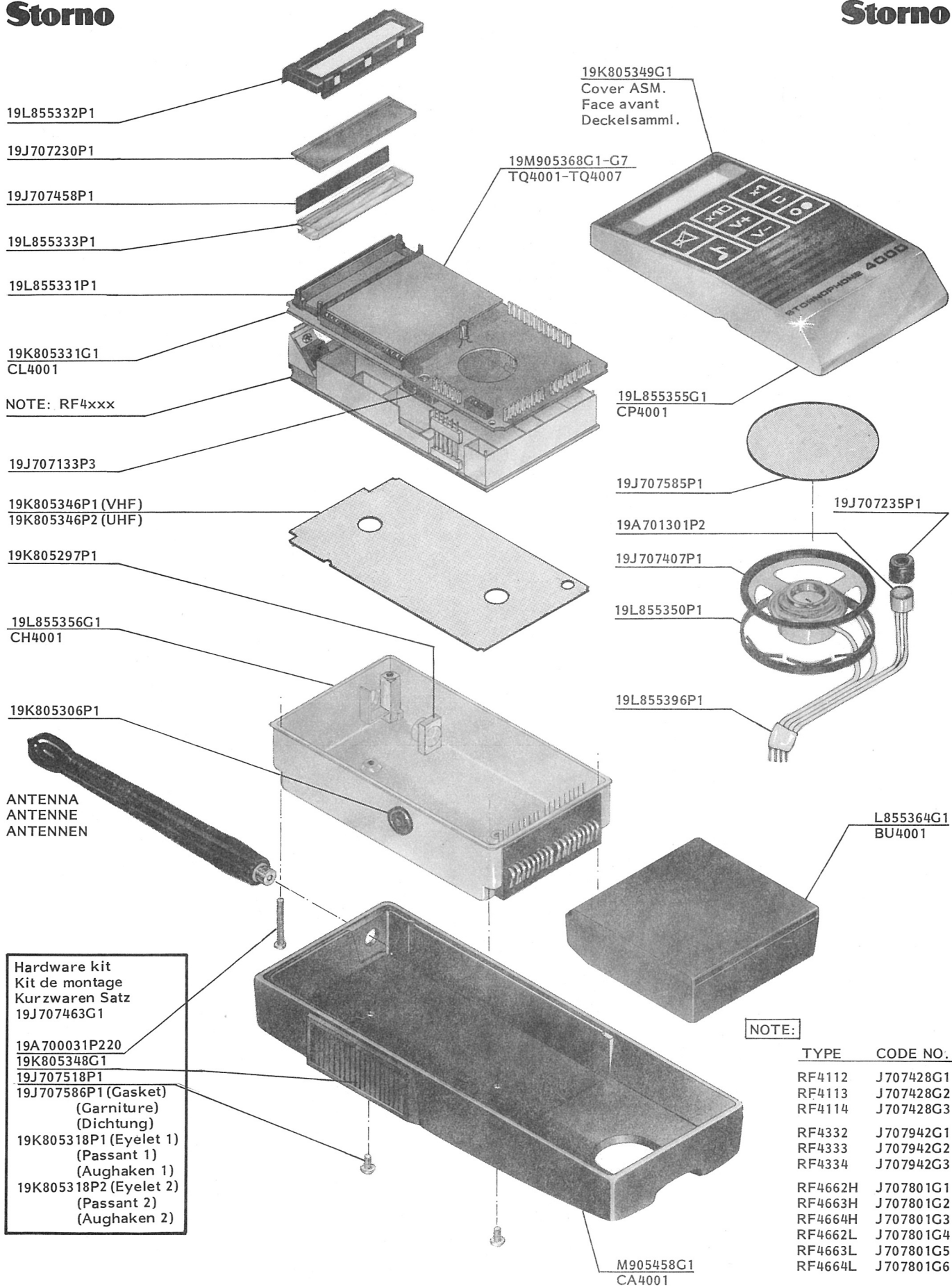

NOTE:

TYPE	CODE NO.
RF4112	J707428G1
RF4113	J707428G2
RF4114	J707428G3
RF4332	J707942G1
RF4333	J707942G2
RF4334	J707942G3
RF4662H	J707801G1
RF4663H	J707801G2
RF4664H	J707801G3
RF4662L	J707801G4
RF4663L	J707801G5
RF4664L	J707801G6

MECHANICAL LAYOUT & PART NUMBERS  
SCHEMA MECANIQUE & NUMEROS DE PIECES  
MECHANISCHE ZEICHNUNG & TEILENUMMERN

CQP4000

M405. 110/2

CQP4000 : -  
LIST of  
MECHANICAL COMPONENTS

ITEM NO.	PART NUMBER	DESCRIPTION	Included in MODULE:
1	19J707133P3	PTT-microswitch	CL4001
2	19J707230P1	LCD,- Liquid Crystal Display	CL4001
3	19L855332P1	Display cover	CL4001
4	19J707458P1	Conductorstrip, conduct.silc.rubb.	CL4001
5	19L855333P1	Lightguide, acrylic	CL4001
6	19L855331P1	Display housing	CL4001
7	19K805349G1	Cover assy.,w.Keyboard, w.out LS and MC	CP4001
8	19L855396P1	LS-/MC cabling, flex-board	CP4001
9	19A701301P2	MC, - microphone	CP4001
10	19J707407P1	LS, - loudspeaker	CP4001
11	19J707235P1	Gasket f. MC, silc.rubb.	CP4001
12	19L855350P1	Lock-ring f. LS, delrin	CP4001
13	19J707585P1	Netting f. LS	CP4001
14a	19K805346P1	Shielding plate f. VHF freq. sttn.'s	
14b	19K805346P2	Shielding plate f. UHF freq. sttn.'s	
15	19K805306P1	Cover gasket f. PTT-switch	CH4001
16	19K805297P1	Bushing-connector f. Antenna	CH4001
17	<u>19J707463G1</u>	<u>Hardware Kit:</u>	(CA4001)
17a	19A700031P220	Screw, M2 x 20 mm, flt.h.	19J707463G1
17b	19J707518P1	Spec. screw, M2 mm	19J707463G1
17c	19K805348G1	PTT-button, assembly	19J707463G1
17d	19J707586P1	Gasket, adjustable	19J707463G1
17e	19K805318P1	Eyelet, f.carrying strap	19J707463G1
17f	19K805318P2	Eyelet 2, f. carrying strap	19J707463G1
18	19L855403P1	Dust cover	

Service Coordination