

TECHNICAL SPECIFICATIONS

CQM5110-2RC

Guaranteed performance specifications unless otherwise noted.

Typical values are given in brackets.

GENERAL

Frequency Range

146 - 174 MHz

Channel Separation

CQM5112-2RC: 30/25 kHz

CQM5113-2RC: 20 kHz

CQM5114-2RC: 12.5 kHz

Maximum Frequency Deviation

CQM5112-2RC: ± 5 kHz

CQM5113-2RC: ± 4 kHz

CQM5114-2RC: ± 2.5 kHz

Modulation Frequency Range

CQM5112-2RC: 300 - 3000 Hz

CQM5113-2RC: 300 - 3000 Hz

CQM5114-2RC: 300 - 2550 Hz

Maximum RF Bandwidth

1.5 MHz. 2 channel groups within a 15 MHz frequency range

Antenna Impedance

50 ohm

Number of Channels

2 to 6

Supply Voltage

Minimum : 10.8 V

Nominal : 13.2 V

Maximum : 16.6 V

Negative potential to chassis

Temperature Range

-30° C to $+60^{\circ}$ C

Dimensions

B x D x H: 180 x 190 x 60mm

Weight

1.8 Kg

RECEIVER

Sensitivity

12dB SINAD (EIA), $\frac{1}{2}$ e.m. f.

0.4 μ V (0.25 μ V)

20 dB SINAD (CEPT) e.m. f.

CQM5112-2RC: 0.75 μ V (0.55 μ V)

CQM5113-2RC: 0.75 μ V (0.55 μ V)

CQM5114-2RC: 1.0 μ V (0.75 μ V)

Measured with psophometric filter.

Crystal Frequency Range

45.1 - 54.5 MHz

Crystal Frequency Calculation (fx)

$$f_x = \frac{F_s - 10.7}{3} \text{ MHz}$$

Frequency Stability

Conforms with government regulations

Modulation Acceptance Bandwidth (EIA)CQM5112-2RC: ± 7 kHz (± 7.5 kHz)Adjacent Channel Selectivity

EIA

CQM5112-2RC: 75 dB (90 dB)

FTZ

CQM5113-2RC: 70 dB (88 dB)

CEPT

CQM5112-2RC: 75 dB (90 dB)

CQM5114-2RC: 65 dB (88 dB)

Spurious Rejection

EIA

80 dB (85 dB)

Intermodulation Attenuation

EIA

CQM5112-2RC: 70 dB (72 dB)

CQM5113-2RC: 70 dB (72 dB)

CEPT

CQM5112-2RC: 70 dB (75 dB)

CQM5113-2RC: 70 dB (75 dB)

CQM5114-2RC: 70 dB (73 dB)

Blocking

90dB/uV (104 dB/uV)

AF Load Impedance (Loudspeaker)

4 ohm

AF Power Output

3 W (3.6 W)

AF Distortion

5% (1.5%)

 $\Delta f = 60\% \Delta f \text{ max.}, 1 \text{ KHz}, 1 \text{ W}, \text{ RF } 1 \text{ mV}$ Audio Frequency Response

+1/-3 dB (+0/-1.5 dB) CEPT

Relative to 1000 Hz, -6 dB/octave

fm: CQM5112-2RC: 300 - 3000 Hz

CQM5113-2RC: 300 - 3000 Hz

CQM5114-2RC: 300 - 2550 Hz

+1/-1.5 dB (+0/-1 dB) FTZ

fm: CQM5113-2RC: 400 - 2700 Hz

Hum and Noise

Squelched : 80 dB (better than 85 dB)

Unsquelched : 55 dB (60 dB)

Squelch Recovery Time

250 ms (200 ms)

Squelch Attack Time

150 ms (110 ms) EIA

Squels Closing Time

150 ms (50 ms) EIA

Current Consumption

Squelched: 180 mA (160 mA)

AF 2W: 550 mA (500 mA)

(2 channels, without tone equipment,

13.2 V supply)

TRANSMITTER

RF Power Output

CQM5110-2RC 6/10: 6 or 10 W

CQM5110-2RC 25: 25 W

RL = 50 ohm

Crystal Frequency Range

48.6 - 58 MHz

Crystal Frequency Calculation (fx)

$$f_x = \frac{F_s}{3}$$

Frequency Stability

Conforms with government regulations

400 - 2700 Hz

+1/-1.5 dB (+0.5/-1 dB) FTZ
relative to 1000 Hz, 6 dB/octave

Undesired Radiation

max. 0.2 μ W

Modulation Distortion

$f_m = 1000$ Hz: 3% CEPT

Sideband Noise Power, CEPT

70 dB

$f_m = 300$ Hz: 5%

$\Delta f = 60\% \Delta f_{max}$.

AF Input Impedance

560 ohm

FM Hum and Noise

70 dB

Modulation Sensitivity

90 mV \pm 2dB

(60% ΔF max, 1 KHz)

CEPT (measured with 750 usec de-emphasis)

Modulation Response

300 - 3000 Hz, 300 - 2550 Hz

+1/-3.0 dB (+0.5/-2 dB) EIA

relative to 1000 Hz, 6 dB/octave

Current Consumption

6W: less than 3 A (2.5 A)

10W: less than 3.5 A (3.0 A)

25W: less than 5.9 A (5.0 A)

GENERAL DESCRIPTION

CQM5110-2RC

The Stornophone 5000 is a mobile radiotelephone unit with self-contained controls and loudspeaker.

A comparison of the various models are presented in the table below.

Although compact in size, it contains a transmitter/receiver, optimal 5-tone sequential encoder/decoder or Channel Guard, and up to 6 transmit and receive channels.

Type	CQM5112-2RC		CQM5113-2RC		CQM5114-2RC	
SPEC	6/10	25	6/10	25	6/10	25
Frequency Range MHz	146 - 174		146 - 174		146 - 174	
RF Power W	6/10	25	6/10	25	6/10	25
Channel Spacing kHz	30/25		20		12, 5	
Number of Channels	2 to 6		2 to 6		2 to 6	

CQM5110-2RC is identical with CQM5110 with the following changes:

RF5110 is replaced by RF5110-2RC and an interface unit, IU5001, is mounted on the channel selector board side in the CQM5000.

The interface unit IU5001 includes of a diode matrix selecting the receiver channel group and an adjustable DC-voltage network determining the distance between the two receiver channel groups.

The receiver channel frequencies may be arbitrarily selected from two groups within a 15 MHz antenna frequency range.

The transmitter channel frequencies can be selected within a 5 MHz antenna frequency range. RF5110-2RC has no built-in RX and TX oscillators for one channel set. The channel switches (multifrequency boards) XS 5111 and 5112 must therefore always be used.

Switching between simplex and semi-duplex channels is performed by the normal channel selector switch.

ACCESSORIES

Standard accessories include:

- Mounting frame
- Power cable
- Fist microphone with retainer or
- Fixed - mount microphone
- External loudspeaker
- External switches

MN5001

Mounting frame for mobile installations allowing the radio to be fixed in 36 positions. Includes a base plate with locking screw.

MN703

Desk stand for fixed installations.

MN704a

Mounting frame for mobile installations and direct attachment to the vehicle.

MC5001

Fist microphone with retractable spiral cable for mobile installation.

HS5001 Retainer for MC5001

HS5002 Retainer, with switches, for MC5001

MC704

Microphone with chockabsorbing mounting bracket for mobile installation.

MC703

Desk microphone with PTT switch for fixed installations.

MK5001

Installation kit containing connectors, power cable, fuses and fuseholders.

LS701

Loudspeaker enclosed in a plastic housing, complete with cable.

SU701

Transmitter keying switch for mounting on the steering column.

SU702

Transmitter keying switch for mounting on the dashboard.

PS702/PS704

Power supply regulators for 24 V car battery installations, PS702: 25 W, PS704: 10 W max.

PS5001/PS703

Power supply for 220 V AC mains.

PS5001: 25 W and 10 W max.

PS703: 10 W max.

MECHANICAL AND ELECTRICAL DESCRIPTION

The internal construction of CQM5000 is on an H-frame chassis with a shelf separating the receiver/transmitter (RF) printed circuit board and the various option printed boards. Front panel controls are an integral part of the printed board assemblies.

The chassis is a die cast aluminium frame comprising the left and right sides, the back, and a shelf located midway between the top and bottom. The chassis front is open and looks like an "H" viewed from the front.

Interconnection to the package exterior and to internal options are made via a System Interconnect Board located on the option side of the H-frame. A test connector is also located on the system board and is accessible from the rear of the radio.

This board also serves as channel switch unit.

The moulded plastic front is directly attached to the chassis and has the speaker mounted to it. A separate moulded speaker grill and aluminium nameplate are attached to the front.

The top and bottom covers slides under the edge of the front and are then secured by screws at the rear.

The tone signalling encoder/decoder board (TQ) and the multifrequency board (XS) mount in the top section of the chassis. Their switches and push buttons mount directly to the boards and protrude through the front.

Thin casted shields with adjustment holes are placed over the transmitter and receiver oscillators and parts of the transmitter in order to reduce spurious radiation.

CIRCUIT DESCRIPTION

RECEIVER

The receiver circuitry is placed on the main board and can be divided into:

Receiver front end

1st IF section with first and second oscillator 455 kHz 2nd IF portion with demodulator.

FRONT-END

The receiver front-end consists of a dual-resonator input filter, a transistor RF amplifier, Q401, a triple-resonator intermediate filter and a FET mixer, Q402. The drain of the FET is terminated in the first IF resonant circuit which adapts the output impedance to the crystal filter. The front-end, antenna relay, first mixer and part of the transmitter PA interconnections are design in micro-stripline techniques on the main-board.

RF5110-2RC has a varicap diode in each of the five receiver front-end coils (L401, L402, L403, L404, L405) and in each of the two receiver injection coils (L303, L305).

The DC-voltage for the varicap diodes is supplied from the interface unit output terminal (H9).

1st IF

The first IF frequency is 10.7 MHz. The output from the crystal filter is fed to a dual-gate MOSFET amplifier, Q501, the output signal of which is fed to the second mixer, U501, a single balanced, self-oscillating, active mixer. Out of the second mixer comes the 455kHz IF signal. Two diodes, D501-502, limit the output from the mixer.

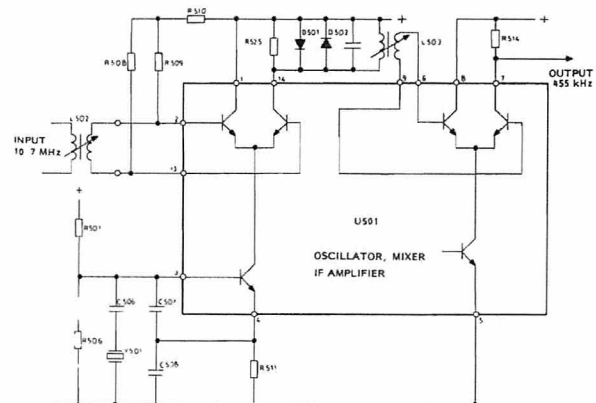

455kHz IF/DEMODULATOR

The selectivity of the 455kHz IF amplifier is formed by a ceramic filter fed from a 455kHz amplifier/impedance transforming stage. The final 455 kHz amplification and limiting is performed by an integrated circuit, U502, which also contains the quadrature FM detector and the AF amplifier/output emitter follower for the audio line signal.

SQUELCH

The audio line signal (Vol/Sq - HI) is fed to a selective amplifier stage, where noise (frequencies around 8 kHz) is extracted from the audio signal. Via the squelch potentiometer R607, this signal reaches an expander stage which improves the level discrimination characteristics of the circuit. A passive voltage doubler circuit (D603-D604) with high source impedance performs the action of an average value rectifier. A Schmitt Trigger gives the necessary hysteresis and a well-defined output from the following buffer stage, Q605.

In the squelched condition and during transmissions this output is +1.5V and mutes the audio power amplifier. The transmit indicator is part of the muting function.

A push button switch, S601, cancels the squelch function, when depressed, by grounding the base of Q601.

AUDIO CIRCUITS

In sets with Pilot tone option, the audio line as signal is fed to the Pilot tone board for filtering and back to the main board. In sets without CG this path is bypassed and the audio line signal is fed directly to the passive deemphasis network R629-C608 followed by the volume control. The volume control potentiometer R630 is mounted directly on the RF board and protrude through the front panel. The audio output amplifier U601 is a monolithic IC package capable of driving the loudspeaker at the desired power level. The output amplifier can be muted with a DC signal from the audio mute gate, which combines different logic signals to decide whether the amplifier should be active or not.

These inputs are:

- Regulated TX Voltage
- Squelch cancel
- Squelch signal

In sets equipped with Pilot tone and/or 5-tone sequential option, an RX mute function is routed from the option board to make the extra mute conditions possible. The value of C610 in the feed back loop is chosen as the best compromise between battery ripple rejection and receiver squelch attack time.

The pilot lamp in the channel knob is supplied from A+, but controlled by the regulated 8.5 V via transistor Q968.

INTERFACE UNIT IU5001

The choice of receiver channel group, low- or high antenna frequency, is made by connecting or disconnecting the wires (W101 to W106) from the channel selector (S901) on the XS5111/2 board to the input terminals (H1 to H6) on the IU5001 board.

With connections (the lower freq. group), the transistor (Q901) on XS 5111/2 earth the IU5001 input terminal and the voltage for the varicap diodes is determined by the setting of the potentiometer R102.

With no connections (the higher freq. group), the voltage for the diodes is fixed (app. 7 V) and determined by the voltage divider R101 and R103.

D107, in series with the varicap diode voltage, is a diode for temperature compensation.

TRANSMITTER

The transmitter consists of a modulation processor, an exciter, and a power amplifier, all assembled on the main board along with the receiver.

The exciter contains an FM oscillator, an audio processor, all frequency multiplier functions, and includes those stages operating at low enough power levels to avoid heat sinks. The exciter output is at the carrier frequency when applied to the power amplifier. The power amplifier boosts the signal to the proper level, and includes a low pass filter for suppressing

harmonics and a circuitry which permits adjustment of the operating power level. The PA low pass filter connects to the antenna relay via a stripline on the board.

MODULATION PROCESSOR

The signal from the microphone load R901 on the XS board is applied to amplifier U101b. The transmitter audio frequency response is shaped by the feedback network R104-R103-C104.

The modulation limiting is obtained in the feedback network formed by D101, D102, R105, R106 and R107. The maximum permissible frequency deviation is set by R116 in single channel sets. In multichannel sets the potentiometer is turned to maximum and the deviation adjusted individually; refer to XS5111 and XS5112.

Amplifier U101A is operated as an active lowpass splatter filter feeding the modulating input of the FM oscillator.

EXCITER

The exciter takes the third harmonic of the crystal oscillator, filters it to reduce spurious signals and amplifies it. Four amplifier stages (Q201-2-3-4) and four filters (L204-5-8-9) are used in a narrow band design which limits the maximum frequency spread of the transmitter. The exciter has three test points (TP201-2-3) for measurements and alignment.

POWER AMPLIFIER

The PA is constructed on the main board and employs two broadband untuned amplifier stages Q205, Q206. Two amplifier configurations are available providing options of power levels of 10 watts or 25 watts. A power control circuit is included to sense the output RF level and keep it constant with variations in temperature and supply voltage. This circuit also limits the peak power to less than maximum, as specified by the authorities, while still maintaining the output as near maximum as possible. The output power level can be set with a potentiometer, R215, over at least a 3:1 range. The transmitter delivers rated power into a 50-ohm load. A load SWR of 1.4:1 will result in more than 90% of the power being radiated. The transmitter will operate into a load with up to 3:1 SWR.

The power adjustment is achieved by controlling the supply voltage of power amplifier Q205 via transistor Q207. This series transistor is biased by a voltage generated by the feedback network C255, D201, Q201, Q209, Q208.

OSCILLATORS AND MULTIPLIER

The oscillators are located on the main board for single frequency radio sets. All parts for the oscillators and compensation network are soldered to the board except the crystal which is a plug-in type.

A multifrequency board is required for more than one frequency channel. This board is available in two versions; one (XS5111) has space for accommodating two transmit and two receive channels; one (XS5112) has space for up to six channels and an option for selecting the channels by a 3-digit BCD signal binary converter, U901-U902. The BCD signal is applied to three pins in D911. Separate active circuitry is used for each oscillator and all have their outputs connected to two buffer amplifiers Q927-Q967. The buffers' outputs are fed to their resonant circuit on the main board by a plug-in connection (J301-J151).

The required oscillator is selected by switching the emitter of the oscillator transistor to the negative DC supply. The compensation voltage and audio for the oscillators is obtained from the same circuit on the main board via J902.

The maximum transmitter frequency deviation for the system is set by adjusting potentiometers, one for each channel, individually on each channel.

The oscillator uses a Colpitt's configuration with a bipolar transistor as the active element. The frequency is controlled by a third mode crystal which is operated at one third of the output frequency. This output frequency is selected by a tuned circuit in the transistor collector circuit. To provide modulation and compensation capability, the crystal, a variable inductor, and a vari-

cap (variable capacitance diode) are connected in series. The inductor provides adjustment of the frequency to set the oscillator to the channel frequency. The varicap permits electrical adjustment of the frequency. Compensation voltage is generated by a resistor - thermistor network and applied to the varicap. A resistor in parallel with the crystal prevents oscillations with the crystal removed from the circuit.

TRANSMITTER OSCILLATOR

In the transmitter the circuit is used with the following additions. First, an inductor is placed

across the crystal to resonate C_0 thus minimizing the audio distortion in the modulated output. Second, the audio voltage is superimposed on the compensating bias voltage to give the required deviation.

RECEIVER OSCILLATOR

In the receiver the oscillator circuit has a buffer amplifier connected between the collector of the oscillator transistor and the tuned circuit, to provide the required power level.

SUPPLY VOLTAGE DISTRIBUTION SYSTEM

The battery voltage (A + BATT) enters the radio via two pins of the rear system connector to the interconnect board. Both inputs are connected to reverse polarity protection diodes D901, D902. The ground lead comes through the same connector and is connected to chassis ground through a fusible printed wiring path which will open in case of the ground wire being accidentally connected to A +.

One battery input goes directly from the interconnect board via a feed-through capacitor and a connector P201 to the transmitter PA stages. The other input feeds through P903 to the main board for two functions. One branch for the audio amplifier passes through an RC-ripple filter R638 - C618 and one of the ON/OFF switch sections U602. The other section of the ON/OFF switch controls the $V_B +$ to the voltage regulator S602 consisting of a monolithic regulator. The regulator output is fixed at 8.5V by means of a factory adjusted resistor.

Regulated 8.5 V is switched to either the receiver or the transmitter by the antenna relay. The antenna relay is also supplied by the 8.5 V regulated.

The squelch circuit, the modulation processor and parts of the IF amplifier U502 is supplied directly from the continuous 8.5 V.

The receiver front-end, the receiver oscillator, the 10.7 MHz IF stages and the second oscillator are supplied from 8.5 V RX. The transmitter oscillator and the exciter are supplied from 8.5V TX.

In sets with 5-tone sequential option or Pilot tone, the PTT (Push to talk) lead runs through the option board to provide for correct tone keying function.

WARNING

The transmitter PA transistors contain Beryllia which is poisonous when absorbed by the human body. Dissection, filing, or grinding of these transistor may be hazardous.

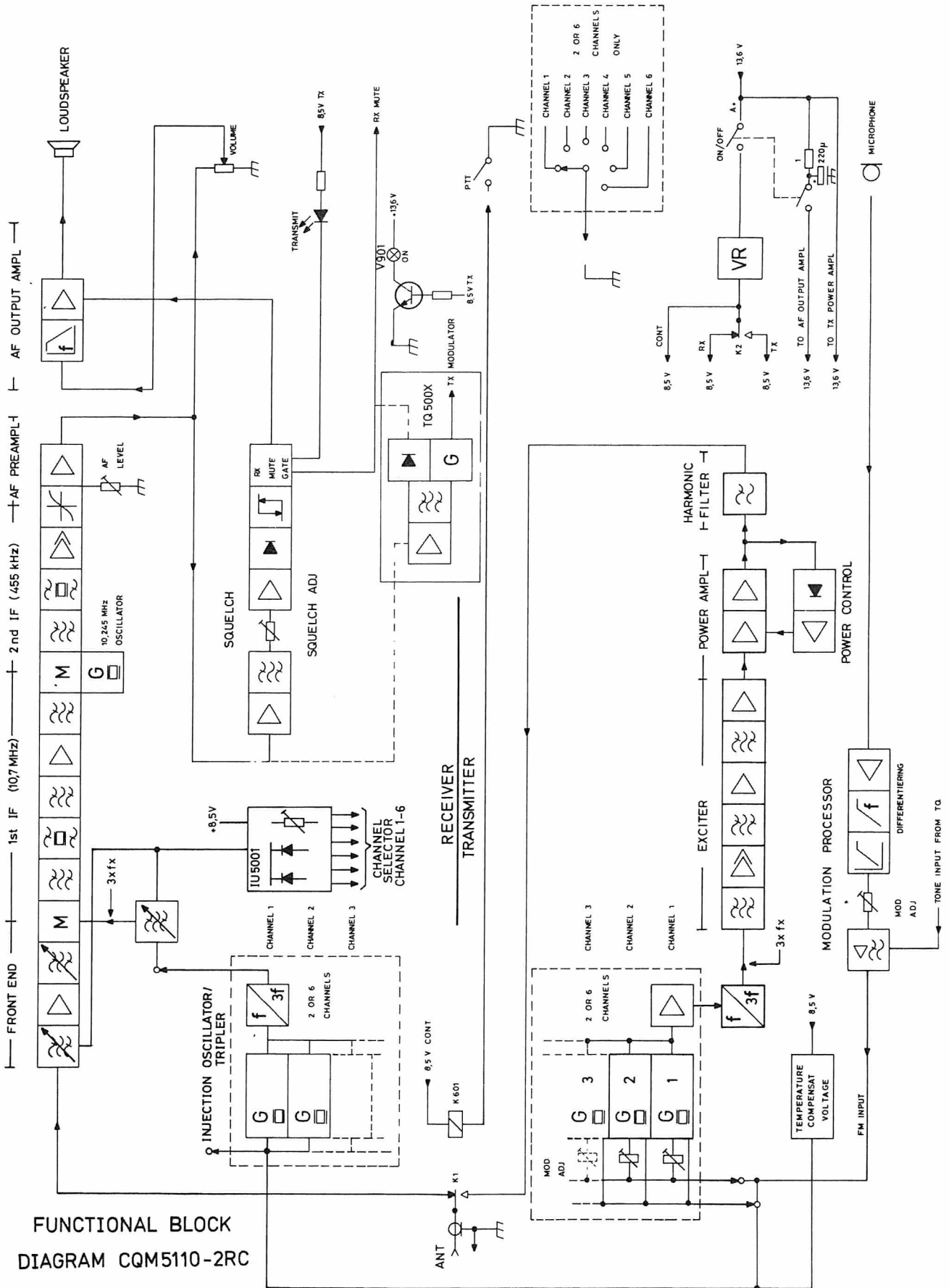

FUNCTIONAL BLOCK
DIAGRAM CQM5110-2RC

D403.362

ADJUSTMENT PROCEDURE

CQM5110-2RC

The adjustment procedure for CQM5110 (next chapter, 60.381-E2) also applies to CQM5110-RC2 with the following modifications in the receiver adjustment.

Remove the wires (W10X) for the numbers of receiver channels chosen to be in the high antenna frequency group and connect (solder) the wires (W10X) on the XS board for the rest of the receiver channels, chosen to be in the low antenna frequency group.

CONNECTIONS

Check that all necessary straps are made on XS5111/XS5112. See IU5001 diagrams D403.111 and D403.112.

When the simplex/semi-duplex frequencies and channel number assignation are known, modification of the wiring W101-106 between XS511X and IU5001 can be made.

	From IU5001	To XS5000
Channel 1: W101	H1	H101
Channel 2: W102	H2	H102
Channel 3: W103	H3	H103
Channel 4: W104	H4	H104
Channel 5: W105	H5	H105
Channel 6: W106	H6	H106

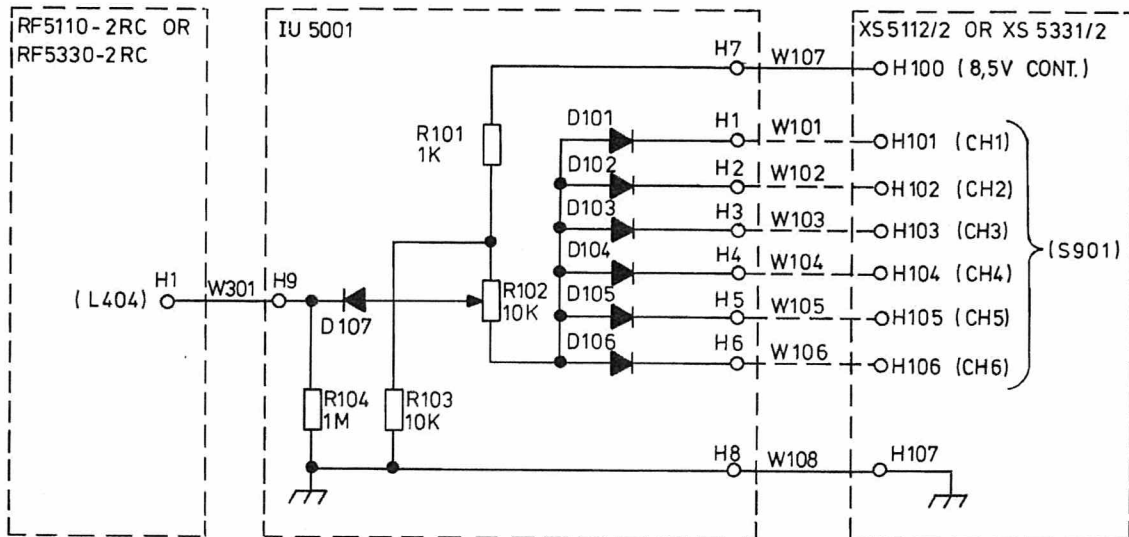

INTERFACE UNIT IU5001

D403.111

OSCILLATORS AND MULTIPLIER

Requirement: $F_{nom} \pm 0.4 \text{ p.p.m. at } 25^{\circ}\text{C.}$
 ($\pm 60 \text{ Hz at } 150 \text{ MHz}$)

High frequency group

No connections between IU5001 and XS5111/2.

The crystals are inserted.

Select the center channel frequency of the high frequency group. Set potentiometer R102 on IU5001 approximately to mid-position.

Proceed with the adjustment as in the rest of the adjustment procedure for CQM5110 (from "Oscillators and frequency multipliers"), adjusting only the coils corresponding to this group.

Adjust the RF generator to the new center frequency.

SENSITIVITY

Check the 12 dB SINAD sensitivity on all channels in the group.

Readjust R102 on IU5001 for highest SINAD reading.

Requirement: Sensitivity $< 0,4 \text{ u V.}$

Low frequency group

The connections between IU5001 and XS5111/2 have to be inserted.

The crystals are inserted.

Select the center frequency channel of low group.

If sensitivity requirement is not fulfilled readjust L401 - 402 - 403 - 404 - 405 for maximum sensitivity. Refer to the adjustment procedure of CQM5110.

Check sensitivity on high frequency channel group.

Connect the probe to the multimeter. Connect the probe to TP401.

Adjust the coils L96x - L96y for maximum deflexion on the multimeter (adjust only the coils corresponding to this group).

Adjust R102 on IU5001 for max. reading on the multimeter.

Repeat adjustment of the front end until sensitivity requirement is fulfilled for both high and low channel groups.

Connect the frequency counter to the probe.

Read the frequency. Adjust L96x - L96y for specified frequency .

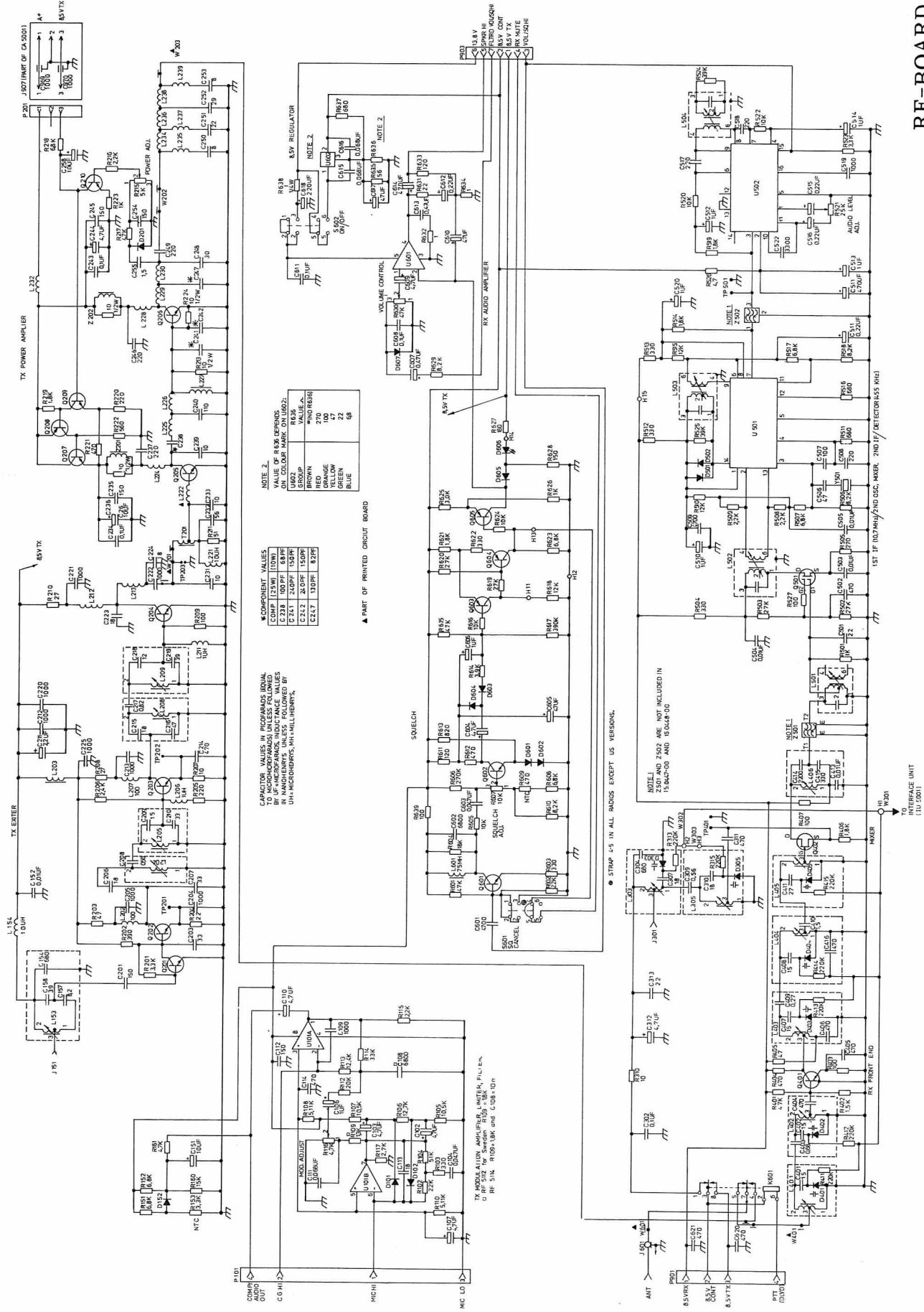

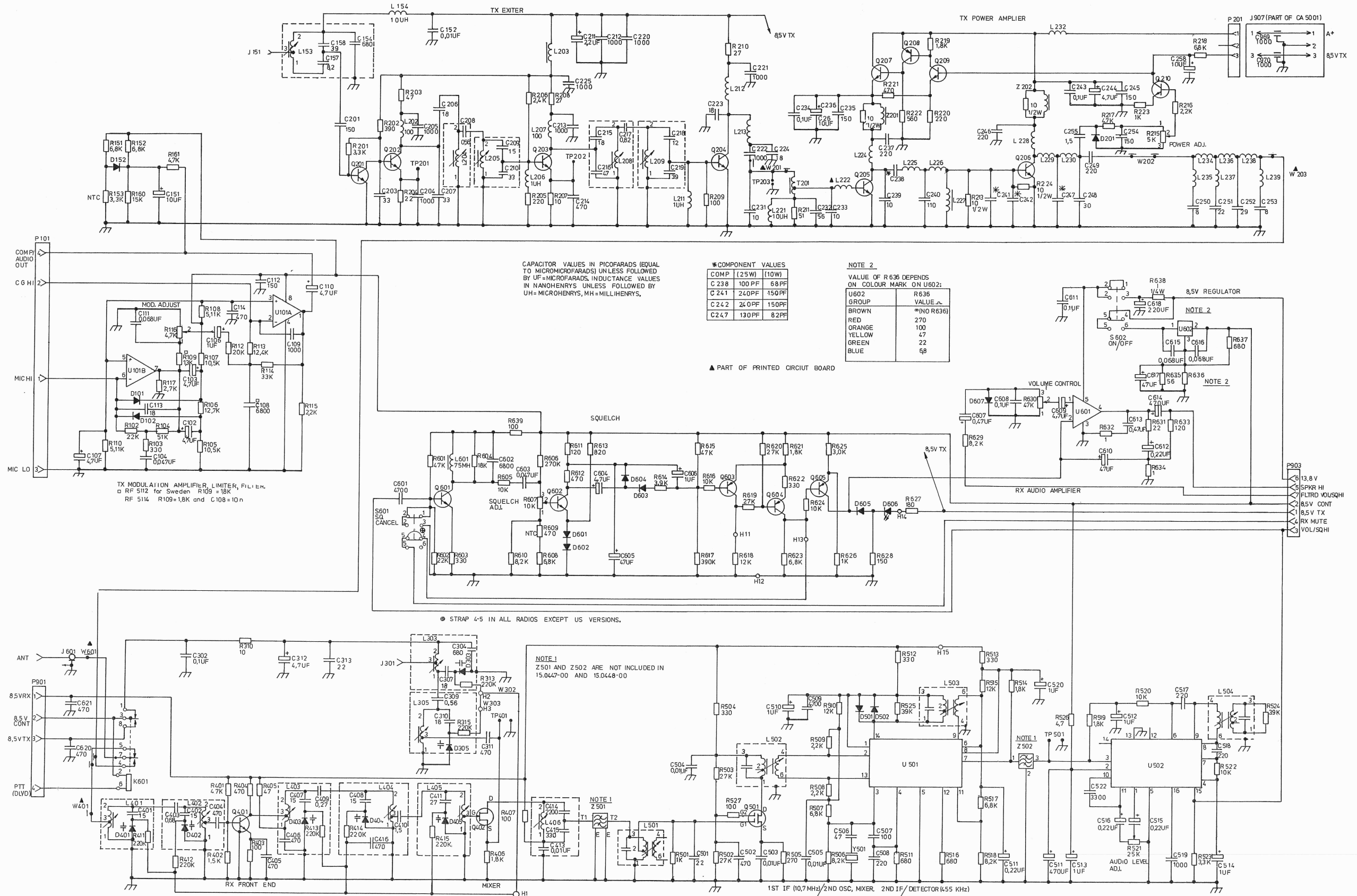

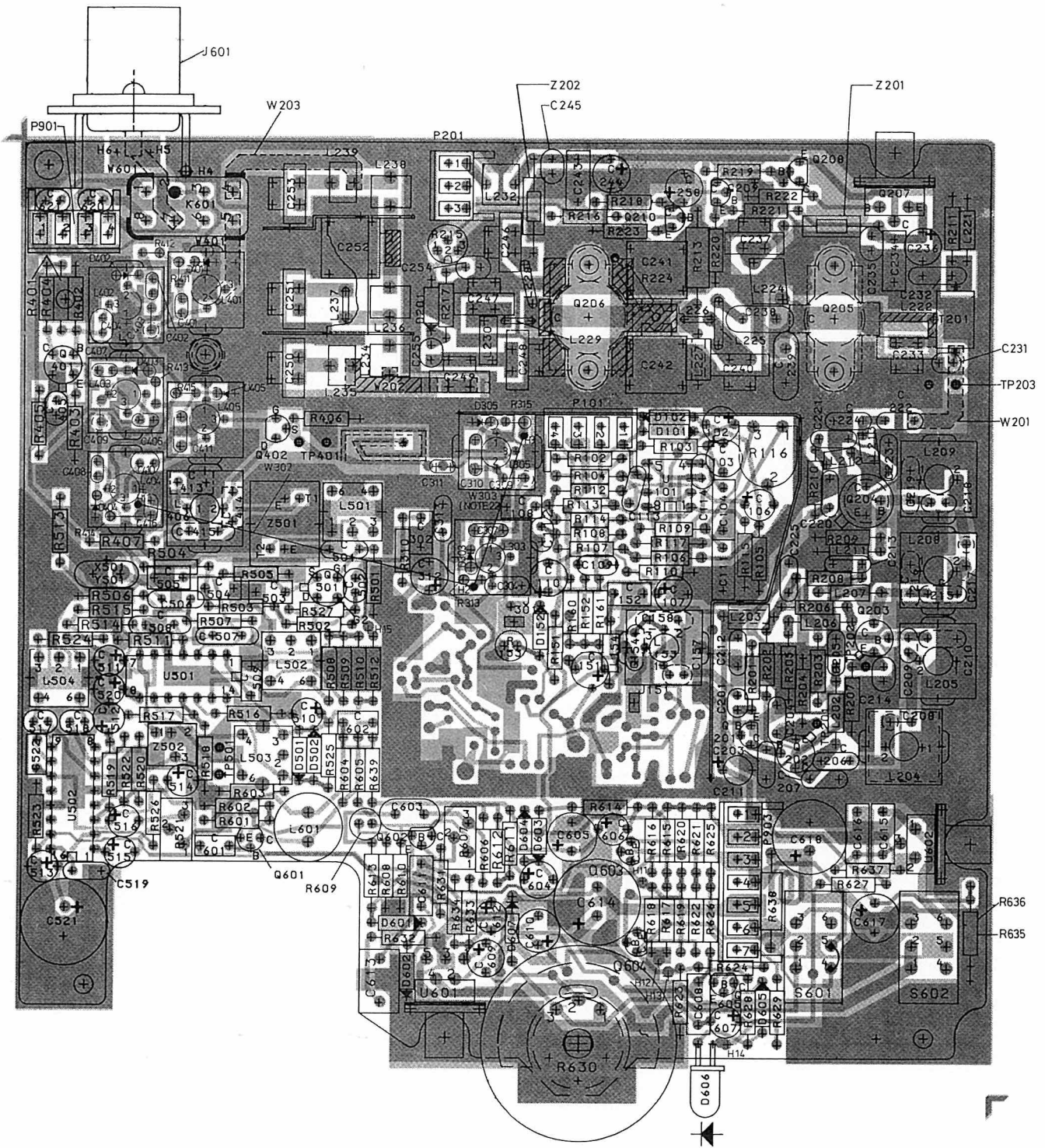

RF-BOARD RF 5110-2RC
COMPONENT LAYOUT

D403.110

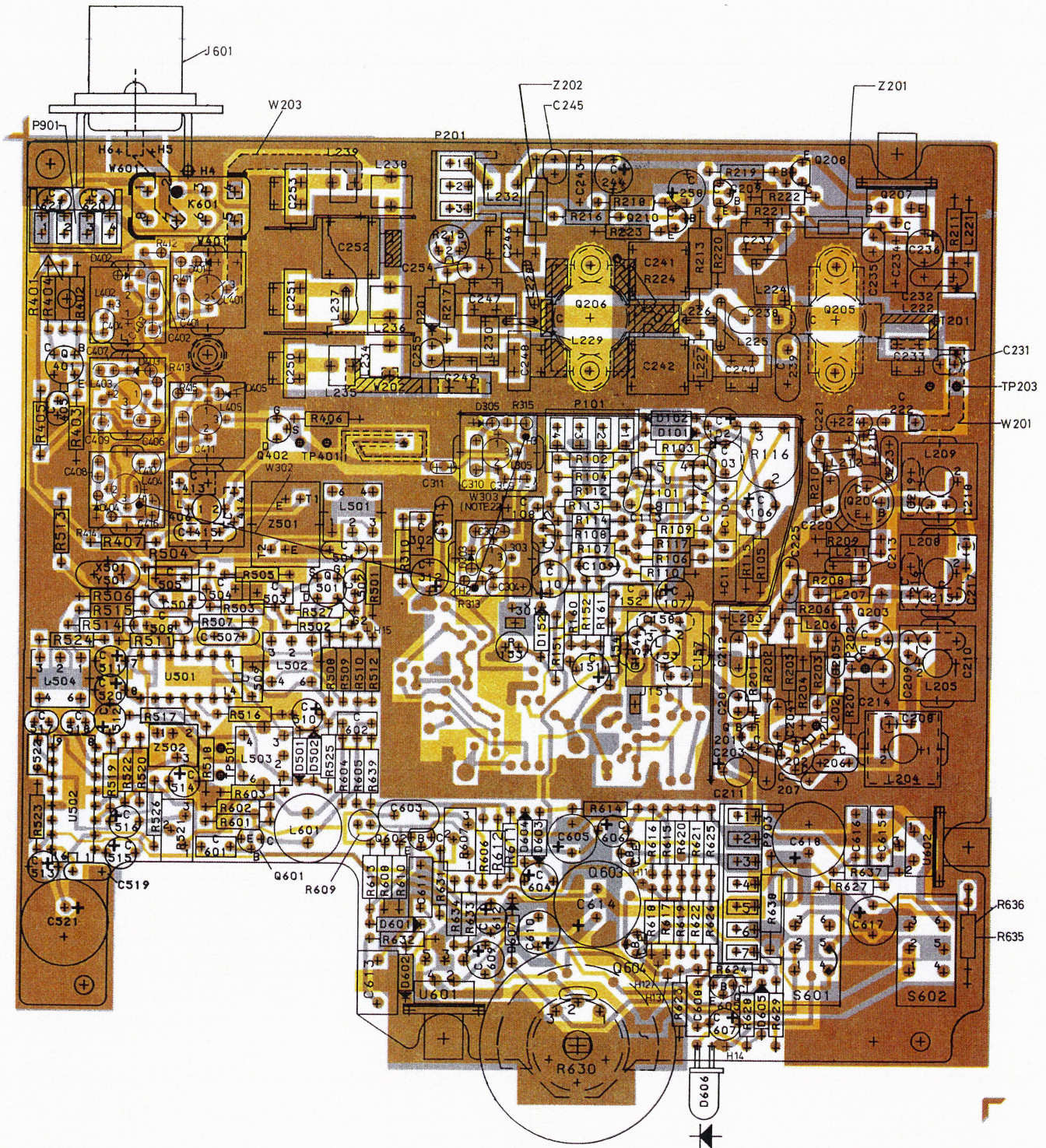

RF-BOARD RF5110-2RC
COMPONENT LAYOUT

D403.110

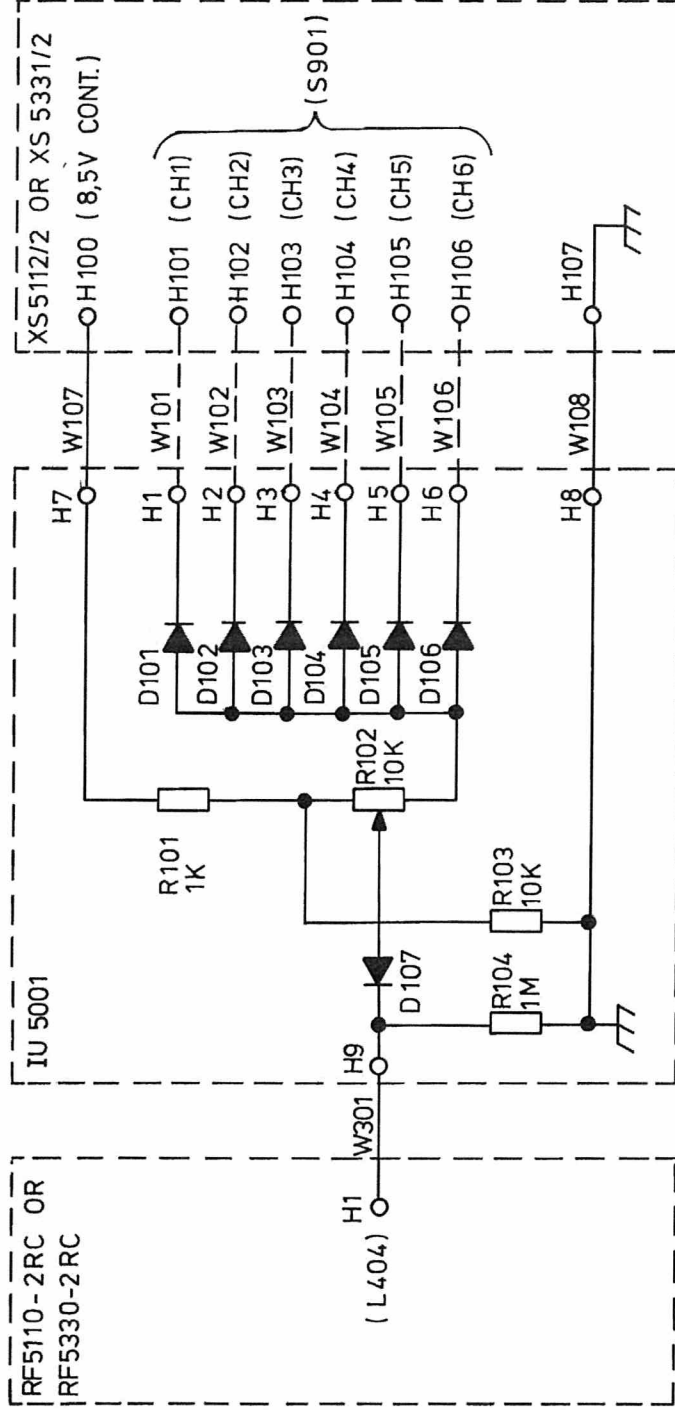

INTERFACE UNIT IU5001

D403.111

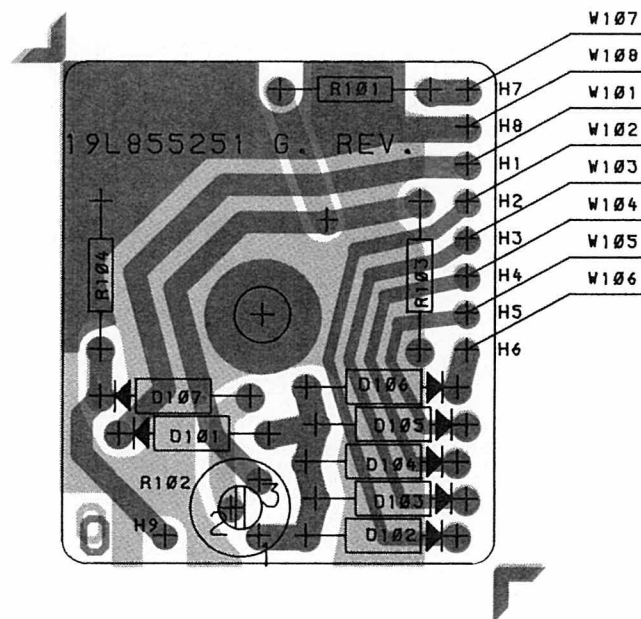

INTERFACE UNIT IU5001
COMPONENT LAYOUT

D403.112

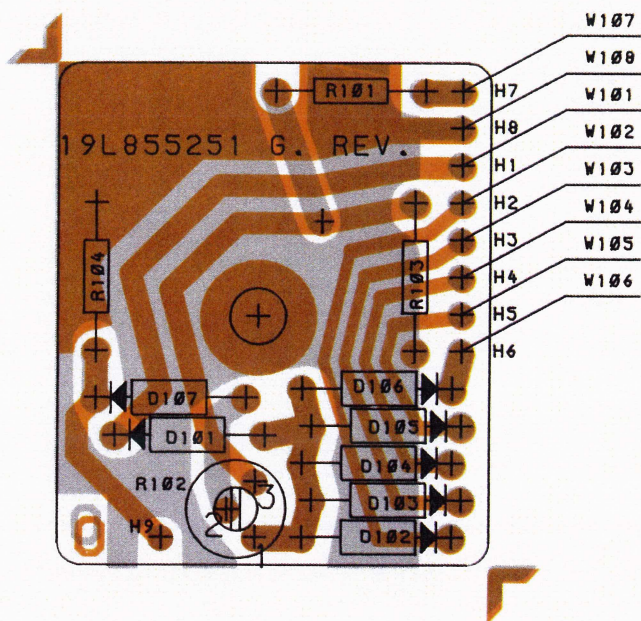

INTERFACE UNIT IU5001
COMPONENT LAYOUT

D403.112

TECHNICAL SPECIFICATIONS

CQM5110 S12

Guaranteed performance specifications unless otherwise noted.

Typical values are given in brackets.

GENERAL

Frequency Range

146 - 174 MHz

Channel Separation

CQM5112: 30/25 kHz

CQM5113: 20 kHz

CQM5114: 12.5 kHz

Maximum Frequency Deviation

CQM5112: ± 5 kHz

CQM5113: ± 4 kHz

CQM5114: ± 2.5 kHz

Modulation Frequency Range

CQM5112: 300 - 3000 Hz

CQM5113: 300 - 3000 Hz

CQM5114: 300 - 2550 Hz

Maximum RF Bandwidth

RX: 1.5 MHz

TX: 2.5 MHz

Antenna Impedance

50 ohm

Maximum Number of Channels

12

Supply Voltage

Minimum : 10.8 V

Nominal : 13.2 V

Maximum : 16.6 V

Negative potential to chassis

Temperature Range

-30°C to $+60^{\circ}\text{C}$

Dimensions

B \times D \times H: 180 \times 90 \times 60 mm

Weight

1.8 Kg

RECEIVER

Sensitivity

12 dB SINAD (EIA), $\frac{1}{2}$ e.m.f.

0,4 μV (0,3 μV)

60% Δf_{max} ; $f_{\text{mod}} = 1$ kHz

20 dB SINAD (CEPT) e.m.f.

CQM5112: 0.75 μV (0.55 μV)

CQM5113: 0.75 μV (0.55 μV)

CQM5114: 1.0 μV (0.75 μV)

60% Δf_{max} ; $f_{\text{mod}} = 1$ kHz.

Measured with psophometric filter.

Crystal Frequency Range

43 - 53 MHz

Receiver VCO Frequency Range

135 - 163 MHz

Frequency Stability

Conforms with governments regulations

Modulation Acceptance Bandwidth (EIA)CQM5112: ± 7 kHz (± 7.5 kHz)Adjacent Channel Selectivity

EIA

CQM5112: 75 dB (87 dB)

FTZ

CQM5113: 70 dB (87 dB)

CEPT

CQM5112: 75 dB (87 dB)

CQM5114: 65 dB (85 dB)

Spurious Rejection EIA

80 dB

Intermodulation Attenuation

EIA

CQM5112: 70 dB (72 dB)

CEPT

CQM5112: 70 dB (75 dB)

CQM5113: 70 dB (75 dB)

CQM5114: 70 dB (73 dB)

FTZ

CQM5113: 70 dB (72 dB)

Blocking

90 dB/uV (104 dB/uV)

Radiation

Conducted: max 0.8 nW

Radiated: max. 0.8 nW

AF Load Impedance (Loudspeaker)

4 ohm

AF Power Output

3 W

AF Distortion

5% (1.5%)

60% Δf max., 1 kHz, 1 W, RF 1 mWModulation Response

CQM5112

300 - 3000 Hz

+1/-3 dB (+0.5/-2 dB)

relative to 1000 Hz, 6 dB/octave

CQM5113

400 - 2700 Hz

+1/-1.5 dB (+0.5/-1 dB)

300 - 400 Hz

2700 - 3000 Hz

+1.5/-3 dB (+0.5/3 dB)

relative to 1000 Hz, 6 dB/octave

CQM5114

300 - 2550 Hz

+1/-3 dB (+0.5/-2 dB)

Relative to 1000 Hz, -6 dB/octave

Hum and Noise (EIA)

Squelched: 80 dB (better than 85 dB)

Unsquelched: 55 dB (57 dB)

Recovery Time

250 ms (200 ms)

Attack Time (EIA)

150 ms (110 ms)

Squelch Closing Time (EIA)

150 ms (50 ms)

Current Consumption

Squelched: 350 mA (330 mA)

Receive; AF 2 W: 750 mA (730 mA)

(without tone equipment, 13.2 V supply)

TRANSMITTER

RF Power Output

CQM5110-6/10 W: 6/10 W

CQM5110 25 W: 25 W

 $R_L = 50 \text{ ohm}$ Crystal Frequency Range

47 - 56 MHz

Crystal Frequency Multiplication

x3

Transmitter VCO Frequency Range

146 - 174 MHz

Frequency Stability

Conforms with government regulations

Undersired Radiation

max. 0.2 uW

Sideband Noise Power (CEPT)

Better than 70 dB

AF Input Impedance

560 ohm

Modulation Sensitivity90 mV \pm 3 dB(60% Δf max, 1 kHz)Modulation Response

CQM5112

300 - 3000 Hz

+1/-3 dB (+0.5/-2 dB)

relative to 1000 Hz, 6 dB/octave

CQM5113

400 - 2700Hz

+1/-1.5 dB (+0.5/-2 dB)

300 - 400 Hz

2700 - 3000 Hz

+1.5/-3 dB (+0.5/-2 dB)

relative to 1000 Hz, 6 dB/octave

CQM5114

300 - 2550 Hz

+1/3 dB (+0.5/-2 dB)

relative to 1000 Hz, 6 dB/octave

Modulation Distortion

fm = 1000 Hz: max. 3%

60% Δf max.

fm = 300 Hz: max. 5%

5.5% Δf max.

measured with 750 us de-emphasis

FM Hum and Noise (CEPT)

55 dB (57 dB)

(measured with 750 us de-emphasis and psophometric filter).

Current Consumption

CQM5110 -6/10 W: less than 3/3.5 A (2.5/3 A)

CQM5110 -25 W: less than 5.9 A (5 A)

GENERAL DESCRIPTION

CQM5110 S12

The Stornophone 5000 is a mobile radiotelephone unit with self-contained controls and loudspeaker.

Although compact in size, it contains a transmitter/receiver, optional 5-tone sequential encoder/decoder or Channel Guard, and up to 12 transmit and receive channels.

A comparison of the various models is presented in the table below.

Type	CQM5112		CQM5113		CQM5114	
SPEC	6/10	25	6/10	25	6/10	25
Frequency Range MHz	146 - 174		146 - 174		146 - 174	
RF Power W	6/10	25	6/10	25	6/10	25
Channel Spacing kHz	30/25		20		12, 5	
Max. Number of Channels	12		12		12	

ACCESSORIES

STANDARD ACCESSORIES

Mounting frame

Power cable

Fist microphone with retainer or

Fixed - mount microphone

External loudspeaker

External switches

LS701 Loudspeaker enclosed in a plastic housing, complete with cable.

MC702b Dynamic fist microphone with adjustable output level.

JB701a Junction box for MC702b. Consists of a plastic housing provided with cable for soldering assembly. Junction box is to mounted behind the first microphone retainer.

MC703a Desk microphone with PTT (Push -to - Talk) switch for fixed installations.

MC704 Microphone with chockabsorbing mounting bracket for mobile installation.

MK704 Mounting kit consisting of 2 flexible tubes, used for mounting the MC704 in close-talk position.

MC5001

HS5001

HS5002

MC5002

HS5003

HS5004

MK5001

MN703

MN704

MN5001

MN5002

MT5001

Fist microphone with retractables piral cable for mobile installation.

Retainer for MC5001

Retainer, with switches, for MC5001

Cylindrical handmicrophone with build-in amplifier and press-to talk switch. Fitted with a coiled cord terminated into a connector which fits into the microphone retainer.

Retainer for MC5002, without hook switch.

Retainer for MC5002, with hook switch.

Installation kit containing connectors, power cable, fuses and fuseholders.

Desk stand for fixed installations.

Mounting bracket for the radio cabinet.

Mounting frame for mobile installations allowing the radio to be fixed in 36 positions. Includes a base plate with locking screw.

Mounting cassette for the radio cabinet (see mechanical layout).

Microphone with retainer. The retainer contains a microswitch which is

	used to switch off the internal loud-speaker, when the microphone is lifted.
SU701	Transmitter keying switch for mounting on the steering column.
SU702	Transmitter keying switch for mounting on the dashboard.
SU704	Switch circuit for autoradio mounting.
SU5003	External alarm with timer (Horn Alarm).

POWER SUPPLY UNITS:

Equipment	SUPPLY 220V AC	VOLTAGE +24V DC
CQM5000, max. 5 W	PS703	PS704
CQM5000, max. 20 W	PS5001	PS702

MECHANICAL AND ELECTRICAL DESCRIPTION

The internal construction of CQM5000 is on an H-frame chassis with a shelf separating the receiver/transmitter (RF) printed circuit board and the various option printed boards. Front panel controls are an integral part of the printed board assemblies.

The chassis is a die cast aluminium frame comprising the left and right sides, the back, and a shelf located midway between the top and bottom. The chassis front is open and looks like an "H" viewed from the front.

Interconnection to the package exterior and to internal options are made via the Frequency Synthesizer Board located on the option side of the H-frame. A test connector is also located on the synthesizer board and is accessible from the rear of the radio.

The moulded plastic front is directly attached to the chassis and has the speaker mounted to it. A separate moulded speaker grill and aluminum nameplate are attached to the front.

The top and bottom covers slide under the edge of the front and are then secured by screws at the rear.

The tone signalling encoder/decoder board (TQ), the Frequency Synthesizer Board (FS), and the Frequency Control (FC) mount in the top section of the chassis. Their switches and push buttons mount directly to the boards and protrude through the front. Thin casted shields with adjustment holes are placed over the transmitter and receiver oscillators and parts of the transmitter in order to reduce spurious radiation.

RECEIVER DESCRIPTION

The receiver circuitry is placed on the main board and can be divided into:

Receiver front end

1st IF section with first and second oscillator

455 kHz 2nd IF portion with demodulator.

(refer to functional block diagram)

FRONT-END

The receiver front-end consists of a dual-resonator input filter, a transistor RF amplifier, Q401, a triple-resonator intermediate filter and a FET mixer, Q402. The drain of the FET is terminated in the first IF resonant circuit which adapts the output impedance to the cry-

stal filter. The front-end, antenna relay, first mixer and part of the transmitter PA interconnections are designed in micro-stripline techniques on the mainboard.

1st IF

The first IF frequency is 10.7 MHz. The output from the crystal filter is fed to a dual-gate MOSFET amplifier, Q501, the output signal of which is fed to the second mixer, U501, a single balanced, self-oscillating, active mixer. Out of the second mixer comes the 455 kHz IF signal. Two diodes, D501-502, limit the output from the mixer.

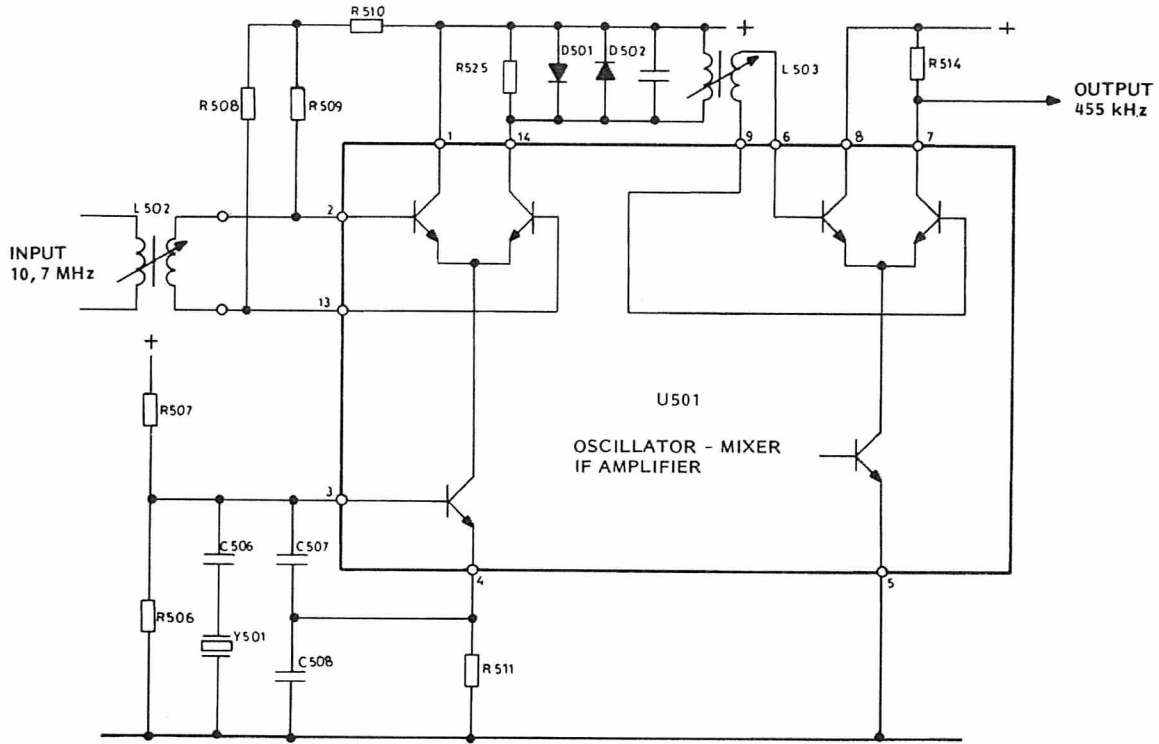

FIG. 1. SECOND OSCILLATOR , IF MIXER , AND IF AMPLIFIER

455 kHz IF/DEMODULATOR

The selectivity of the 455 kHz IF amplifier is formed by a ceramic filter fed from a 455 kHz amplifier/impedance transforming stage. The

final 455 kHz amplification and limiting is performed by an integrated circuit , U502, which also contains the quadrature FM detector and the AF amplifier/output emitter follower for the audio line signal.

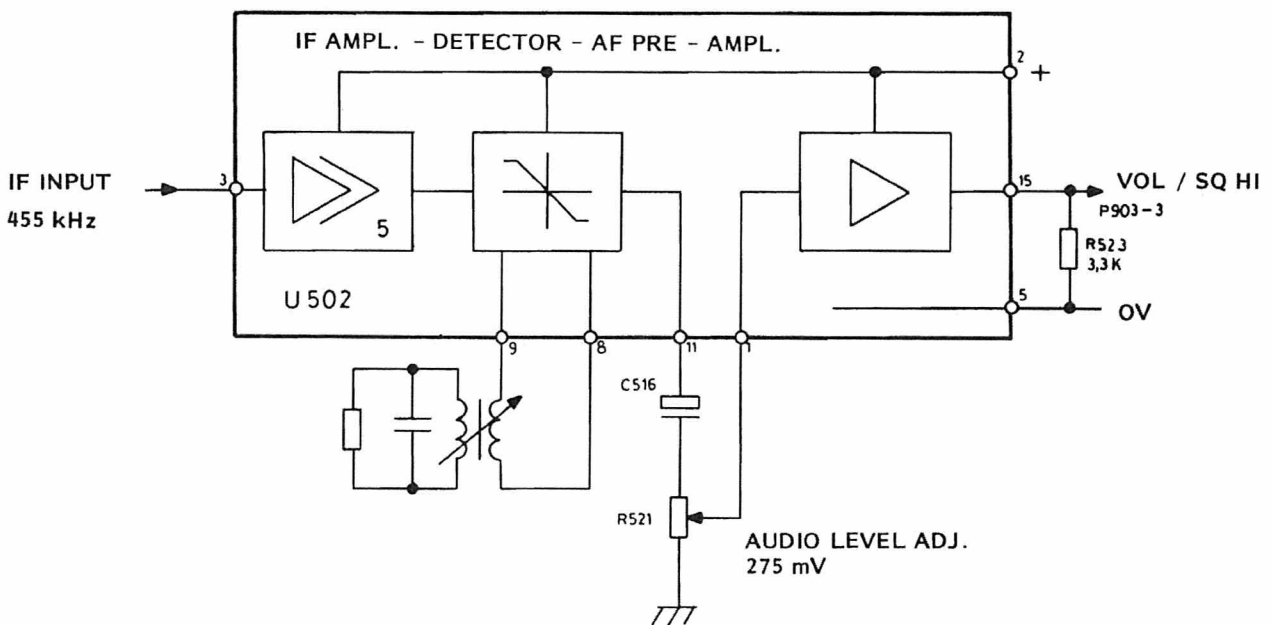

FIG. 2. IF AMPLIFIER , DETECTOR , AND AF PREAMPLIFIER

SQUELCH AND AUDIO CIRCUITS

The audio line signal (Vol/Sq - HI) is fed to a selective amplifier stage, where noise (frequencies around 8 kHz) is extracted from the audio signal. Via the squelch potentiometer R607, this signal reaches an expander stage which improves the level discrimination characteristics of the circuit. A passive voltage doubler circuit (D603-D604) with high source impedance performs the action of an average value rectifier. A Schmitt Trigger gives the necessary hysteresis and a well-defined output from the following buffer stage, Q605. In the squelched condition and during transmissions this output is +1.5 V and mutes the audio power amplifier. The transmit indicator is part of the muting function.

A push button switch, S601, cancels the squelch function, when depressed, by grounding the base of Q601.

AUDIO

In sets with Pilot tone option (CG), the audio line signal is fed to the Pilot tone board for filtering and back to the main board. In sets

without CG this path is bypassed and the audio line signal is fed directly to the passive deemphasis network R629-C608 followed by the volume control. The volume control potentiometer R630 is mounted directly on the RF board and protrude through the front panel. The audio output amplifier U601 is a monolithic IC package capable of driving the loudspeaker at the desired power level. The output amplifier can be muted with a DC signal from the audio mute gate, which combines different logic signals to decide whether the amplifier should be active or not. These inputs are:

- Regulated TX Voltage
- Squelch cancel
- Squelch signal

In sets equipped with Pilot tone and/or 5-tone sequential option, an RX mute function is routed from the option board to make the extra mute conditions possible. The value of C610 in the feed back loop is chosen as the best compromise between battery ripple rejection and receiver squelch attack time.

The pilot lamp in the channel knob is supplied from A+, but controlled by the regulated 8.5 V via transistor Q968.

TRANSMITTER

The transmitter consists of a modulation processor, an exciter, and a power amplifier, all assembled on the main board along with the receiver.

The exciter contains, an audio processor, all frequency multiplier functions, and includes those stages operating at low enough power levels to avoid heat sinks. The exciter output is at the carrier frequency when applied to the power amplifier. The power amplifier boosts the signal to the proper level, and includes a low pass filter for suppressing harmonics and a circuitry which permits adjust-

ment of the operating power level. The PA low pass filter connects to the antenna relay via a stripline on the board.

MODULATION PROCESSOR

The signal from the microphone load R901 on the FS board is applied to amplifier U101b. The transmitter audio frequency response is shaped by the feedback network R104-R103-C104.

The modulation limiting is obtained in the feed-

back network formed by D101, D102, R105, R106 and R107. The maximum permissible frequency deviation is set by a DEV.MAX. potentiometer on the RF board.

Amplifier U101A is operated as an active low-pass splatter filter feeding the modulating input of the VCO on the Frequency Synthesizer board.

EXCITER

The exciter takes the synthesized signal, filters it to reduce spurious signals and amplifies it. Four amplifier stages (Q201-2-3-4) and four filters (L204-5-8-9) are used in a narrow band design which limits the maximum frequency spread of the transmitter.

The exciter has three test points (TP201-2-3) for measurements and alignment.

POWER AMPLIFIER

The PA is constructed on the main board and employs two broadband untuned amplifier stages Q205, Q206. Two amplifier configurations are available providing options of power levels of 10 watts or 25 watts. A power control circuit is included to sense the output RF level and keep it constant with variations in temperature and supply voltage. This circuit also limits the peak power to less than maximum, as specified by the authorities, while still maintaining the output as near maximum as possible. The output power level can be set with a potentiometer, R215, over at least a 3:1 range. The transmitter delivers rated power into a 50-ohm load. A load SWR of 1.4:1 will result in more than 90% of the power being radiated. The transmitter will operate into a load with up to 3:1 SWR.

The power adjustment is achieved by controlling the supply voltage of power amplifier Q205 via transistor Q207. This series transistor is biased by a voltage generated by the feedback network C255, D201, Q201, Q209, Q208.

FREQUENCY SYNTHESIZER

The frequency synthesizer provides up to 12 Channels and is built on a printed wiring board which mounts in the top section of the radioset. There are two versions of the board, a single channel board, FS5111, and a multi-channel board, FS5112.

The frequency of the single channel board is set by putting a binary code directly on the programmable divider input while the multi-channel board uses a channel selector and a Frequency Control unit, FC5001. The channel selector is mounted directly on the synthesizer board and protrudes through the front panel.

The Frequency Control unit FC5001 fits into a shield which is placed over the main section of the synthesizer board.

The Frequency Synthesizer board also carries all interconnections between the tone modules and the RF module, and it has two connectors at the rear for accessories and the power supply cable.

SUPPLY VOLTAGE DISTRIBUTION SYSTEM

The battery voltage (A + BATT) enters the radio via two pins of the rear system connector to the synthesizer board. Both inputs are connected to reverse polarity protection diodes D741, D742. The ground lead comes through the same connector and is connected to chassis ground through a fusible printed wiring path which will open in case of the ground wire being accidentally connected to A +.

One battery input goes directly from the synthesizer board via a feed-through capacitor and a connector P907 to the transmitter PA stages. The other input feeds through P903 - J903 to the main board for two functions. One branch for the audio amplifier passes through an RC-ripple filter R638 - C618 and one of the ON/OFF switch sections S602. The other section of the ON/OFF switch controls the

V_B + to the voltage regulator U602 consisting of a monolithic regulator. The regulator output is fixed at 8.5 V by means of a factory adjusted resistor.

Regulated 8.5 V is switched to either the receiver or the transmitter by the antenna relay. The antenna relay is also supplied by the 8.5 V regulated.

The squelch circuit, the modulation processor, parts of the IF amplifier U502, and the Frequency Synthesizer are supplied directly from the continuous 8.5 V.

The receiver front-end, the 10.7 MHz IF stages and the second oscillator are supplied

from 8.5 V RX. The transmitter exciter is supplied from 8.5 V TX.

In sets with 5-tone sequential option or Pilot tone, the PTT (Push to talk) lead runs through the option board to provide for correct tone keying function.

WARNING

The transmitter PA transistors contain Beryllia which is poisonous when absorbed by the human body. Dissection, filing, or grinding of these transistor may be hazardous.

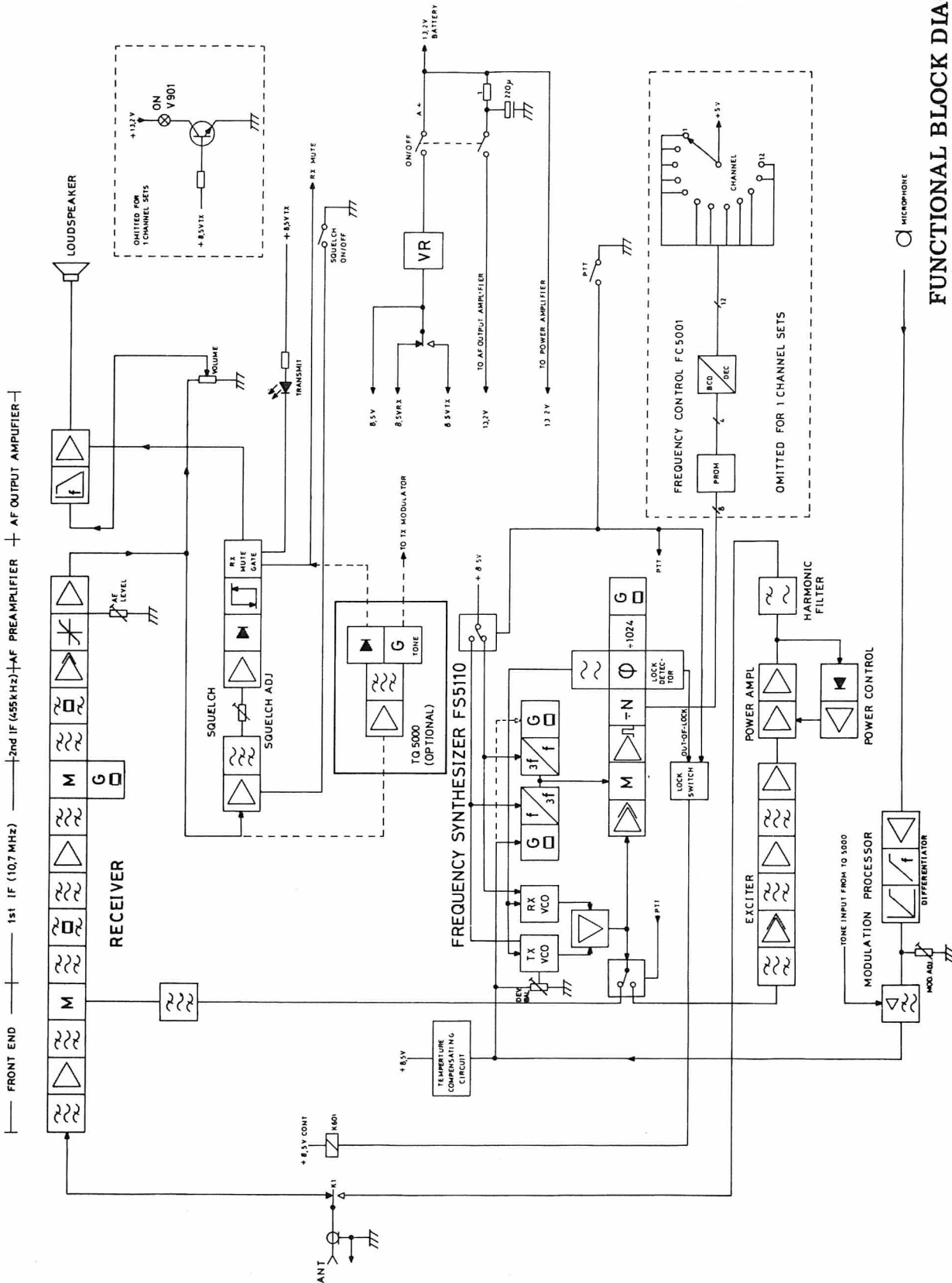

FUNCTIONAL BLOCK DIAGRAM
CQM5110 xx S12

D402868

CHANNEL PROGRAMMING INSTRUCTIONS

CQM5110 S12

Programming of the PROM which contains the data for the channel frequencies will normally be part of the factory process, but it may also be field programmed.

The PROM programming unit must be approved by the PROM manufacturer, as for example (DATA I/O SYSTEM 17 or 19).

The programmer consists of the following items:

Programmer (DATA I/O SYSTEM 19)
 Programming Pak, interchangeable
 Socket adaptor
 or universal programming pack.
 DATA I/O UNIPAK (adaptable for more
 than 200 types of
 PROM devices).

To program a PROM the channel frequencies for all allocated channels and the channel spacing must be known.

It is recommended to complete a worksheet when calculating the prom data.

It is also possible to use a computer to calculate the prom data and Storno will be able to supply software programs for certain types of computers.

Operating instructions for the Programmer is supplied by the vendor.

WORKSHEET

For each PROM to be programmed a worksheet should be completed to calculate the input data for each channel.

The procedure for completing the worksheet is:

1. Complete list of receiver channel frequencies. (A).
2. Complete list of transmitter channel frequencies. (B).
3. Find highest (H) and lowest (L) receiving frequencies.
4. Find highest (H) and lowest (L) transmitting frequencies.
5. Select receiver mixer crystal frequency (C) from table 1. The highest and lowest receiver frequencies must be within the selected band.
6. Select transmitter mixer crystal frequency (D) from table 2. The highest and lowest transmitter frequencies must be within the selected band.
7. Note channel spacing and Reference frequency (F). See worksheet.
8. Use receiver formula to calculate " V_{DEC} " (divisor) for all receiver channels.
9. Use transmitter formula to calculate " V_{DEC} " (divisor) for all transmitter channels.
10. Check " V_{DEC} " for all channels to be between 256 and 511.
11. Use receiver crystal frequency and V_{DEC} to check for selfquieting frequencies, table 3.
12. In case of selfquieting select appropriate alternative and possibly recalculate "V".
13. Convert all " V_{DEC} " numbers to hexadecimal code. Refer to tabel 4.
14. Assign the hexadecimal codes to the corresponding channels and the PROM addresses.

After completing the worksheet the next steps are:

1. Enter correct Prom addresses and corresponding data (V_{HEX}) on the Programmer (DATA I/O), refer to Programmer Operating Instructions.
2. Insert the channel knob stop (if needed) if less than 9 channels, refer to fig. 1.
3. In case of more than 8, but less than 12 channels are used, transmission on unauthorized channels must be avoided. This is done by burning the unused channel locations in the PROM with the highest channel HEX CODE.

CHANNEL STOP

LOWEST CH.	INSERT PIN BETWEEN	HIGHEST CH.	INSERT PIN BETWEEN
1	10 and 11	1	3 and 4
2	11 and 12	2	4 and 5
3	12 and 1	3	5 and 6
4	1 and 2	4	6 and 7
5	2 and 3	5	7 and 8
6	3 and 4	6	8 and 9
7	4 and 5	7	9 and 10
8	5 and 6	8	10 and 11
9	6 and 7	9	11 and 12
10	7 and 8	10	12 and 1
11	8 and 9	11	1 and 2
12	9 and 10	12	2 and 3

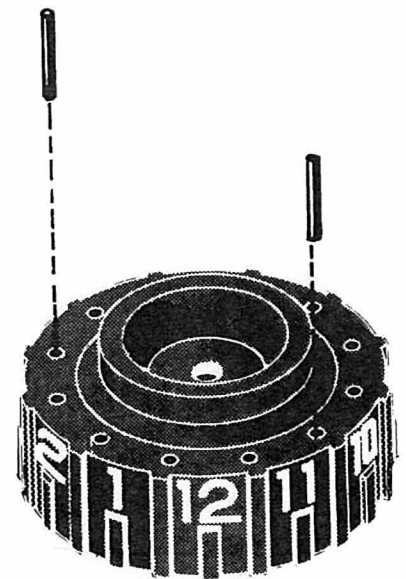

Note: If 8 channels are used insert only one PIN.
If more than 8 channels are used stop is not possible and no PINs are inserted.

Fig. 1. SETTING OF CHANNEL KNOB STOP.

RECOMMENDED CRYSTAL FREQUENCIES

CQM5110

CQM5112 - CQM5114 FREQUENCY RANGE	CQM5113 FREQUENCY RANGE	RX CRYSTAL
145.2 - 148.3875		43.766666
146.2 - 149.3875	145.56 - 148.11	44.1
147.2 - 150.3875	146.56 - 149.11	44.433333
148.2 - 151.3875	147.56 - 150.11	44.766666
149.2 - 152.3875	148.56 - 151.11	45.1
150.2 - 153.3875	149.56 - 152.11	45.433333
151.2 - 154.3875	150.56 - 153.11	45.766666
152.2 - 155.3875	151.56 - 154.11	46.1
153.2 - 156.3875	152.56 - 155.11	46.433333
154.2 - 157.3875	153.56 - 156.11	46.766666
155.2 - 158.3875	154.56 - 157.11	47.1
156.2 - 159.3875	155.56 - 158.11	47.433333
157.2 - 160.3875	156.56 - 159.11	47.766666
158.2 - 161.3875	157.56 - 160.11	48.1
159.2 - 162.3875	158.56 - 161.11	48.433333
160.2 - 163.3875	159.56 - 162.11	48.766666
161.2 - 164.3875	160.56 - 163.11	49.1
162.2 - 165.3875	161.56 - 164.11	49.433333
163.2 - 166.3875	162.56 - 165.11	49.766666
164.2 - 167.3875	163.56 - 166.11	50.1
165.2 - 168.3875	164.56 - 167.11	50.433333
166.2 - 169.3875	165.56 - 168.11	50.766666
167.2 - 170.3875	166.56 - 169.11	51.1
168.2 - 171.3875	167.56 - 170.11	51.433333
169.2 - 172.3875	168.56 - 171.11	51.766666
170.2 - 173.3875	169.56 - 172.11	52.1
171.2 - 174.3875	170.56 - 173.11	52.433333
172.2 - 175.3875	171.56 - 174.11	52.766666
173.2 - 176.3875	172.56 - 175.11	53.1
	173.56 - 176.11	53.433333

TABLE 1. RECEIVER MIXER CRYSTAL FREQUENCY

RECOMMENDED CRYSTAL FREQUENCIES

CQM5110

CQM5112 - CQM5114 FREQUENCY RANGE	CQM5113 FREQUENCY RANGE	TX CRYSTAL
145.5 - 148.6875	144.86 - 147.41	47.433333
146.5 - 149.6875	145.86 - 148.41	47.766666
147.5 - 150.6875	146.86 - 149.41	48.1
148.5 - 151.6875	147.86 - 150.41	48.433333
149.5 - 152.6875	148.86 - 151.41	48.766666
150.5 - 153.6875	149.86 - 152.41	49.1
151.5 - 154.6875	150.86 - 153.41	49.433333
152.5 - 155.6875	151.86 - 154.41	49.766666
153.5 - 156.6875	152.86 - 155.41	50.1
154.5 - 157.6875	153.86 - 156.41	50.433333
155.5 - 158.6875	154.86 - 157.41	50.766666
156.5 - 159.6875	155.86 - 158.41	51.1
157.5 - 160.6875	156.86 - 159.41	51.433333
158.5 - 161.6875	157.86 - 160.41	51.766666
159.5 - 162.6875	158.86 - 161.41	52.1
160.5 - 163.6875	159.86 - 162.41	52.433333
161.5 - 164.6875	160.86 - 163.41	52.766666
162.5 - 165.6875	161.86 - 164.41	53.1
163.5 - 166.6875	162.86 - 165.41	53.433333
164.5 - 167.6875	163.86 - 166.41	53.766666
165.5 - 168.6875	164.86 - 167.41	54.1
166.5 - 169.6875	165.86 - 168.41	54.433333
167.5 - 170.6875	166.86 - 169.41	54.766666
168.5 - 171.6875	167.86 - 170.41	55.1
169.5 - 172.6875	168.86 - 171.41	55.433333
170.5 - 173.6875	169.86 - 172.41	55.766666
171.5 - 174.6875	170.86 - 173.41	56.1
172.5 - 175.6875	171.86 - 174.41	56.433333
173.5 - 176.6875	172.86 - 175.41	56.766666
174.5 - 177.6875	173.86 - 176.41	57.1
175.5 - 178.6875	174.86 - 177.41	57.433333
176.5 - 179.6875	175.86 - 178.41	57.766666

TABLE 2. TRANSMITTER MIXER CRYSTAL FREQUENCY

SELFQUIETING FREQUENCIES
CQM5112, CQM5114

RECEIVER CRYSTAL FREQUENCY, MHz	V DEC	USE ALTERNATIVE ⁺
43.766666	428	1
44.1	336	4
44.1	428	1
44.433333	256	4
44.433333	428	1
44.766666	428	1
45.1	428	1
45.433333	428	1
45.766666	428	1
45.766666	454	2
46.1	374	2
46.433333	294	2
46.766666	428	1
47.1	428	1
47.433333	428	1
47.766666	428	1
48.1	428	1
48.433333	428	1
48.766666	428	1
49.1	428	1
49.1	472	2
49.1	474	2
49.433333	393	2
49.433333	394	2
49.433333	428	1
49.766666	313	2
49.766666	314	2
49.766666	428	1
50.1	428	1
50.1	432	4

TABLE 3A. SELFQUIETING FREQUENCIES

⁺ refer to worksheet

Continued on table 3B

SELFQUIETING FREQUENCIES
CQM5112, CQM5114

RECEIVER CRYSTAL FREQUENCY, MHz	V DEC	USE ALTERNATIVE ⁺
50.433333	428	1
50.766666	272	3
50.766666	428	1
51.1	428	1
51.433333	428	1
51.766666	320	4
51.766666	428	1
52.1	344	4
52.1	428	1
52.433333	428	1
52.766666	304	4

TABLE 3B. SELFQUIETING FREQUENCIES

⁺refer to worksheet

SELFQUIETING FREQUENCIES
CQM5113

RECEIVER CRYSTAL FREQUENCY, MHz	V DEC	USE ALTERNATIVE ⁺
44.1	311	4
46.1	467	2
46.433333	367	2
46.766666	260	4
46.766666	267	2
49.433333	492	2
49.766666	392	2
50.1	292	2
50.433333	290	Avoid this frequency
53.1	390	4

TABLE 3C. SELFQUIETING FREQUENCIES

⁺refer to worksheet

HEX CODE CONVERSION TABLE

		Least Significant Digit (LSD) of Hex Code															
		0	1	2	3	4	5	6	7	8	9	A	B	C	D	E	F
Most Significant Digit of Hex Code.	0	256	257	258	259	260	261	262	263	264	265	266	267	268	269	270	271
	1	272	273	274	275	276	277	278	279	280	281	282	283	284	285	286	287
	2	288	289	290	291	292	293	294	295	296	297	298	299	300	301	302	303
	3	304	305	306	307	308	309	310	311	312	313	314	315	316	317	318	319
	4	320	321	322	323	324	325	326	327	328	329	330	331	332	333	334	335
	5	336	337	338	339	340	341	342	343	344	345	346	347	348	349	350	351
	6	352	353	354	355	356	357	358	359	360	361	362	363	364	365	366	367
	7	368	369	370	371	372	373	374	375	376	377	378	379	380	381	382	383
	8	384	385	386	387	388	389	390	391	392	393	394	395	396	397	398	399
	9	400	401	402	403	404	405	406	407	408	409	410	411	412	413	414	415
	A	416	417	418	419	420	421	422	423	424	425	426	427	428	429	430	431
	B	432	433	434	435	436	437	438	439	440	441	442	443	444	445	446	447
	C	448	449	450	451	452	453	454	455	456	457	458	459	460	461	462	463
	D	464	465	466	467	468	469	470	471	472	473	474	475	476	477	478	479
	E	480	481	482	483	484	485	486	487	488	489	490	491	492	493	494	495
	F	496	497	498	499	500	501	502	503	504	505	506	507	508	509	510	511

"V_{DEC}" Numbers.

Example "V_{DEC}"= 345 equals to hex code 59.
 (Diagram showing 345 with arrows pointing to 3 as MSD and 5 as LSD)

"V_{DEC}"= 469 equals to hex code D5.

Table 4.

"V" Number to hex code conversion table.

PROGRAMMING WORKSHEET

FOR CQM5110 S12



Customer:

RECEIVER						TRANSMITTER					
CHAN- NEL	A FREQUENCY MHz		L	V	PROM ADDRESS (HEX)	B FREQUENCY MHz	L	V	V	PROM ADDRESS (HEX)	
	H		H	DEC	HEX		H	DEC	HEX		
1					00					10	
2					01					11	
3					02					12	
4					03					13	
5					04					14	
6					05					15	
7					06					16	
8					07					17	
9					08					18	
10					09					19	
11					0A					1A	
12					0B					1B	

RECEIVER MIXER CRYSTAL FREQ. (Y702): C= _____ FORMULA: $V_{DEC} = \frac{(A - 10.7) - (C \times 3)}{F}$	TRANSMITTER MIXER CRYSTAL FREQ. (Y701): D= _____ FORMULA: $V_{DEC} = \frac{B - (D \times 3)}{F}$
---	---

CHANNEL SPACING:	REFERENCE CRYSTAL (Y703):	REFERENCE FREQUENCY:
20 kHz	10.240000 MHz	F= 0.01
12.5/25 kHz	12.800000 MHz	F= 0.0125

LIST OF REFERENCE CRYSTALS (Y703)			
MODE	FREQUENCY, MHz	PART No.	
Standard 5112/5114	12.800000	19J706361P1	
Offset 5112	12.801000	19J706361P7	
Offset 5114	12.000500	19J706361P6	
Standard 5113	10.240000	19J706361P2	
Offset 5113	10.240650	19J706361P9	

ALTERNATIVE SOLUTIONS IF THE RECEIVER IS SELFQUIETING:

1. SELECT ANOTHER RX MIXER CRYSTAL FREQUENCY
2. SELECT HIGH SIDE INJECTION FREQUENCY FOR 2nd OSCILLATOR
Y501= 11.15500 MHz INSTEAD OF 10.245000 MHz
3. USE SLIGHTLY OFFSET REFERENCE CRYSTAL
4. WEAK QUIETING; NO ALTERNATIVE REQUIRED

CHANNEL PROGRAMMING INSTRUCTIONS

CQM5110SxxS99

Programming of the PROM which contains the Personality data with normally be part of the factory process, but it may also be field programmed.

The PROM programming unit must be approved by the PROM manufacturer, as for example (DATA I/O SYSTEM 17 or 19).

The programmer consists of the following items:

Programmer (DATA I/O SYSTEM 19)

Programming Pak, interchangeable

Socket adaptor

or universal programming pack.

DATA I/O UNIPAK (adaptable for more than 200 types of PROM devices).

To program a PROM the channel frequencies for all allocated channels and the channel spacing must be known.

It is recommended to complete a worksheet when calculating the prom data.

It is also possible to use a computer to calculate the prom data and Storno will be able to supply software programs for certain types of computers.

Operating instructions for the Programmer is supplied by the vendor.

WORKSHEET

For each PROM to be programmed a worksheet should be completed to calculate the input data for each channel.

The procedure for completing the worksheet is:

1. Complete list of receiver channel frequencies. (A).

2. Complete list of transmitter channel frequencies. (B).
3. Find highest (H) and lowest (L) receiving frequencies.
4. Find highest (H) and lowest (L) transmitting frequencies.
5. Select receiver mixer crystal frequency (C) from table 1. The highest and lowest receiver frequencies must be within the selected band.
6. Select transmitter mixer crystal frequency (D) from table 2. The highest and lowest transmitter frequencies must be within the selected band.
7. Note channel spacing and Reference frequency (F). See worksheet.
8. Use receiver formula to calculate " V_{DEC} " (divisor) for all receiver channels.
9. Use transmitter formula to calculate " V_{DEC} " (divisor) for all transmitter channels.
10. Check " V_{DEC} " for all channels to be between 256 and 511.
11. Use receiver crystal frequency and V_{DEC} to check for selfquieting frequencies, table 3.
12. In case of selfquieting select appropriate alternative and possibly recalculate " V ".
13. Convert all " V_{DEC} " numbers to hexadecimal code. Refer to tabel 4.
14. Assign the hexadecimal codes to the corresponding channels and the PROM addresses.

After completing the worksheet the next steps are:

1. Enter correct Prom addresses and corresponding data (V_{HEX}) on the Programmer (DATA I/O), refer to Programmer Operating Instructions.

RECOMMENDED CRYSTAL FREQUENCIES
CQM5110SxxS99

CQM5112 - CQM5114 FREQUENCY RANGE	CQM5113 FREQUENCY RANGE	RX CRYSTAL
145.2 - 148.3875		43.766666
146.2 - 149.3875	145.56 - 148.11	44.1
147.2 - 150.3875	146.56 - 149.11	44.433333
148.2 - 151.3875	147.56 - 150.11	44.766666
149.2 - 152.3875	148.56 - 151.11	45.1
150.2 - 153.3875	149.56 - 152.11	45.433333
151.2 - 154.3875	150.56 - 153.11	45.766666
152.2 - 155.3875	151.56 - 154.11	46.1
153.2 - 156.3875	152.56 - 155.11	46.433333
154.2 - 157.3875	153.56 - 156.11	46.766666
155.2 - 158.3875	154.56 - 157.11	47.1
156.2 - 159.3875	155.56 - 158.11	47.433333
157.2 - 160.3875	156.56 - 159.11	47.766666
158.2 - 161.3875	157.56 - 160.11	48.1
159.2 - 162.3875	158.56 - 161.11	48.433333
160.2 - 163.3875	159.56 - 162.11	48.766666
161.2 - 164.3875	160.56 - 163.11	49.1
162.2 - 165.3875	161.56 - 164.11	49.433333
163.2 - 166.3875	162.56 - 165.11	49.766666
164.2 - 167.3875	163.56 - 166.11	50.1
165.2 - 168.3875	164.56 - 167.11	50.433333
166.2 - 169.3875	165.56 - 168.11	50.766666
167.2 - 170.3875	166.56 - 169.11	51.1
168.2 - 171.3875	167.56 - 170.11	51.433333
169.2 - 172.3875	168.56 - 171.11	51.766666
170.2 - 173.3875	169.56 - 172.11	52.1
171.2 - 174.3875	170.56 - 173.11	52.433333
172.2 - 175.3875	171.56 - 174.11	52.766666
173.2 - 176.3875	172.56 - 175.11	53.1
	173.56 - 176.11	53.433333

TABLE 1. RECEIVER MIXER CRYSTAL FREQUENCY

RECOMMENDED CRYSTAL FREQUENCIES

CQM5110SxxS99

CQM5112 - CQM5114 FREQUENCY RANGE	CQM5113 FREQUENCY RANGE	TX CRYSTAL
145.5 - 148.6875	144.86 - 147.41	47.433333
146.5 - 149.6875	145.86 - 148.41	47.766666
147.5 - 150.6875	146.86 - 149.41	48.1
148.5 - 151.6875	147.86 - 150.41	48.433333
149.5 - 152.6875	148.86 - 151.41	48.766666
150.5 - 153.6875	149.86 - 152.41	49.1
151.5 - 154.6875	150.86 - 153.41	49.433333
152.5 - 155.6875	151.86 - 154.41	49.766666
153.5 - 156.6875	152.86 - 155.41	50.1
154.5 - 157.6875	153.86 - 156.41	50.433333
155.5 - 158.6875	154.86 - 157.41	50.766666
156.5 - 159.6875	155.86 - 158.41	51.1
157.5 - 160.6875	156.86 - 159.41	51.433333
158.5 - 161.6875	157.86 - 160.41	51.766666
159.5 - 162.6875	158.86 - 161.41	52.1
160.5 - 163.6875	159.86 - 162.41	52.433333
161.5 - 164.6875	160.86 - 163.41	52.766666
162.5 - 165.6875	161.86 - 164.41	53.1
163.5 - 166.6875	162.86 - 165.41	53.433333
164.5 - 167.6875	163.86 - 166.41	53.766666
165.5 - 168.6875	164.86 - 167.41	54.1
166.5 - 169.6875	165.86 - 168.41	54.433333
167.5 - 170.6875	166.86 - 169.41	54.766666
168.5 - 171.6875	167.86 - 170.41	55.1
169.5 - 172.6875	168.86 - 171.41	55.433333
170.5 - 173.6875	169.86 - 172.41	55.766666
171.5 - 174.6875	170.86 - 173.41	56.1
172.5 - 175.6875	171.86 - 174.41	56.433333
173.5 - 176.6875	172.86 - 175.41	56.766666
174.5 - 177.6875	173.86 - 176.41	57.1
175.5 - 178.6875	174.86 - 177.41	57.433333
176.5 - 179.6875	175.86 - 178.41	57.766666

TABLE 2. TRANSMITTER MIXER CRYSTAL FREQUENCY

SELFQUIETING FREQUENCIES
CQM5112SxxS99, CQM5114SxxS99

RECEIVER CRYSTAL FREQUENCY, MHz	V DEC	USE ALTERNATIVE ⁺
43.766666	428	1
44.1	336	4
44.1	428	1
44.433333	256	4
44.433333	428	1
44.766666	428	1
45.1	428	1
45.433333	428	1
45.766666	428	1
45.766666	454	2
46.1	374	2
46.433333	294	2
46.766666	428	1
47.1	428	1
47.433333	428	1
47.766666	428	1
48.1	428	1
48.433333	428	1
48.766666	428	1
49.1	428	1
49.1	472	2
49.1	474	2
49.433333	393	2
49.433333	394	2
49.433333	428	1
49.766666	313	2
49.766666	314	2
49.766666	428	1
50.1	428	1
50.1	432	4

TABLE 3A. SELFQUIETING FREQUENCIES

⁺ refer to worksheet

Continued on table 3B

SELFQUIETING FREQUENCIES
 CQM5112SxxS99, CQM5114SxxS99

RECEIVER CRYSTAL FREQUENCY, MHz	V DEC	USE ALTERNATIVE ⁺
50.433333	428	1
50.766666	272	3
50.766666	428	1
51.1	428	1
51.433333	428	1
51.766666	320	4
51.766666	428	1
52.1	344	4
52.1	428	1
52.433333	428	1
52.766666	304	4

TABLE 3B. SELFQUIETING FREQUENCIES

⁺refer to worksheet

SELFQUIETING FREQUENCIES
 CQM5113SxxS99

RECEIVER CRYSTAL FREQUENCY, MHz	V DEC	USE ALTERNATIVE ⁺
44.1	311	4
46.1	467	2
46.433333	367	2
46.766666	260	4
46.766666	267	2
49.433333	492	2
49.766666	392	2
50.1	292	2
50.433333	290	Avoid this frequency
53.1	390	4

TABLE 3C. SELFQUIETING FREQUENCIES

⁺refer to worksheet

HEX CODE CONVERSION TABLE

		Least Significant Digit (LSD) of Hex Code															
		0	1	2	3	4	5	6	7	8	9	A	B	C	D	E	F
Most Significant Digit of Hex Code.	0	256	257	258	259	260	261	262	263	264	265	266	267	268	269	270	271
	1	272	273	274	275	276	277	278	279	280	281	282	283	284	285	286	287
	2	288	289	290	291	292	293	294	295	296	297	298	299	300	301	302	303
	3	304	305	306	307	308	309	310	311	312	313	314	315	316	317	318	319
	4	320	321	322	323	324	325	326	327	328	329	330	331	332	333	334	335
	5	336	337	338	339	340	341	342	343	344	345	346	347	348	349	350	351
	6	352	353	354	355	356	357	358	359	360	361	362	363	364	365	366	367
	7	368	369	370	371	372	373	374	375	376	377	378	379	380	381	382	383
	8	384	385	386	387	388	389	390	391	392	393	394	395	396	397	398	399
	9	400	401	402	403	404	405	406	407	408	409	410	411	412	413	414	415
	A	416	417	418	419	420	421	422	423	424	425	426	427	428	429	430	431
	B	432	433	434	435	436	437	438	439	440	441	442	443	444	445	446	447
	C	448	449	450	451	452	453	454	455	456	457	458	459	460	461	462	463
	D	464	465	466	467	468	469	470	471	472	473	474	475	476	477	478	479
	E	480	481	482	483	484	485	486	487	488	489	490	491	492	493	494	495
	F	496	497	498	499	500	501	502	503	504	505	506	507	508	509	510	511

Most Significant Digit of Hex Code. "V_{DEC}" Numbers.

Example "V_{DEC}" = 345 equals to hex code 59.
 MSD
 LSD

"V_{DEC}" = 469 equals to hex code D5.

Table 4.

"V" Number to hex code conversion table.

PROGRAMMING WORKSHEET

CQM5110SxxS99

Customer:

RECEIVER						TRANSMITTER					
CHAN- NEL	A FREQUENCY MHz	L H	V DEC	V HEX	PROM ADDRESS (HEX)	B FREQUENCY MHz	L H	V DEC	V HEX	PROM ADDRESS (HEX)	
1					00					10	
2					01					11	
3					02					12	
4					03					13	
5					04					14	
6					05					15	
7					06					16	
8					07					17	
9					08					18	
10					09					19	
11					0A					1A	
12					0B					1B	

RECEIVER MIXER CRYSTAL FREQ. (Y702): C= _____ FORMULA: $V_{DEC} = \frac{(A - 10.7)}{F} - (C \times 3)$	TRANSMITTER MIXER CRYSTAL FREQ. (Y701): D= _____ FORMULA: $V_{DEC} = \frac{B - (D \times 3)}{F}$
---	---

CHANNEL SPACING:	REFERENCE CRYSTAL (Y703):	REFERENCE FREQUENCY:
20 kHz	10.240000 MHz	F= 0.01
12.5/25 kHz	12.800000 MHz	F= 0.0125

LIST OF REFERENCE CRYSTALS (Y703)

MODE	FREQUENCY, MHz	PART No.
Standard 5112/5114	12.800000	19J706361P1
Offset 5112	12.801000	19J706361P7
Offset 5114	12.000500	19J706361P6
Standard 5113	10.240000	19J706361P2
Offset 5113	10.240650	19J706361P9

ALTERNATIVE SOLUTIONS IF THE RECEIVER IS SELFQUIETING:

1. SELECT ANOTHER RX MIXER CRYSTAL FREQUENCY
2. SELECT HIGH SIDE INJECTION FREQUENCY FOR 2nd OSCILLATOR
Y501= 11.15500 MHz INSTEAD OF 10.245000 MHz
3. USE SLIGHTLY OFFSET REFERENCE CRYSTAL
4. WEAK QUIETING; NO ALTERNATIVE REQUIRED

ADJUSTMENT PROCEDURE

CQM5110 S12

This adjustment procedure applies to the following radiotelephone types:

CQM5112 S12	30/25 kHz Channel spacing
CQM5113 S12	20 kHz Channel spacing
CQM5114 S12	12.5 kHz Channel spacing

Frequency counter with attenuator	$Z_{in} = 50 \text{ ohm}$; sensitivity 100 mV at 175 MHz
RF diode probe	Storno 95.0089-00
RF coaxial probe	Storno 95.0179-00
DC power supply	10.8 V - 16.6 V; 6 A
Oscilloscope	0 - 5 MHz min.

Before making adjustments to the radiotelephone transmitter/receiver, read the type label and note the channel frequencies. Check all straps according to the notes on the diagrams. Also check the selective calling tone equipment, if any, against the coding instructions; refer to description of tone equipment. All screens must be in place and properly secured during the adjustments.

MEASURING INSTRUMENTS

The following list contains instruments necessary for adjusting the radiotelephone and checking its performance characteristics:

DC Voltmeter	$R_{in} \geq 1 \text{ Mohm}$
AC Voltmeter	$Z_{in} > 1 \text{ Mohm}/50 \text{ pF}$
Multimeter	$R_i \geq 20 \text{ Kohm/Volt}$
Distortion meter	e.g. Storno E11c
RF Watt meter	25 W/50 ohm/145-175 MHz
Deviation meter	145-175 MHz
RF generator	$Z_{out} = 50 \text{ ohm}$; 145-175 MHz
10.7 MHz signal gen.	e.g. Storno TS-G21B

MISCELLANEOUS

4 ohm/3 W resistor	3 x Storno code 82.5026
22 uF/40 V electrolytic capacitor	Storno code 73.5107-00
Connector, 11-pin house	Storno code 41.5543-00
Connector, 8-pin house	Storno code 41.5542-00
Pins for connectors	Storno code 41.5551-00
Trimming tools	

The following tables show the frequency ranges of the CQM5110 S12 radiotelephone signals:

SIGNAL	Frequency, MHz
TX VCO	146 - 174
TX Crystal	47 - 56
TX Crystal multiplication	x3
RX VCO	135 - 163
RX Crystal	43 - 53
RX Crystal multiplication	x3

Table 1

Channel spacing kHz	Reference Crystal MHz	Min. Divider input frequency MHz	Max. Divider input frequency MHz	Reference frequency kHz
20	10.240	2.560	5.110	10
12.5 or 25 ¹⁾	12.800	3.200	6.3875	12.5
15.0 or 30 ¹⁾	15.360	3.840	7.665	15

Table 2 ¹⁾ Two steps per channel

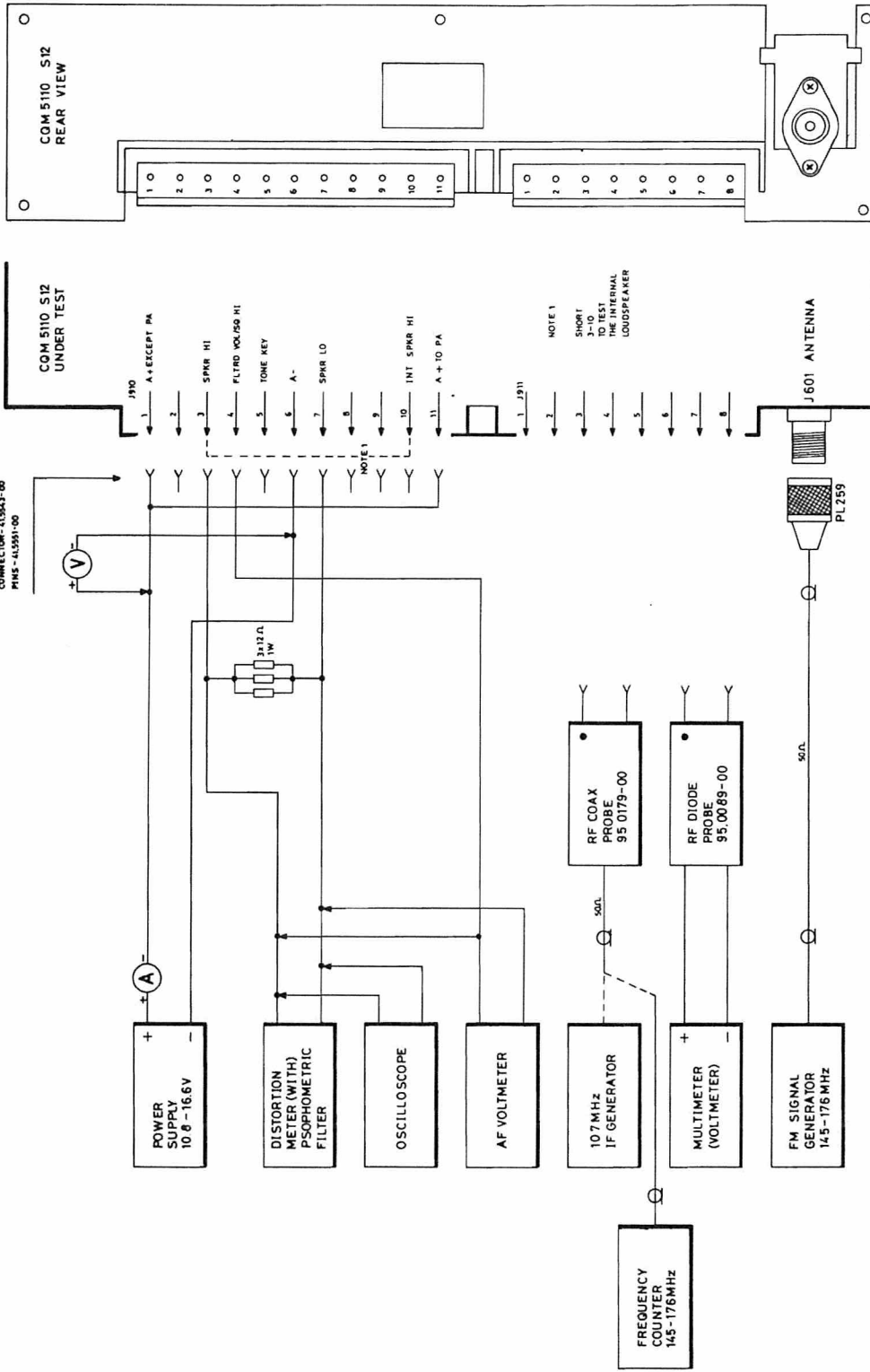

RECEIVER TEST SET-UP
 CQM5110 S12

D402. 876

RECEIVER ADJUSTMENT

CHECKING 8.5 V REGULATED SUPPLY

Turn the power supply ON and set the voltage to 13.2 V. Set the power supply current limiter to 1 A.

Turn the radiotelephone ON by depressing the ON/OFF button. Note the light in the Channel selector, if any, is on.

Depress the Squelch button.

Set the volume control to minimum.

Connect the DC voltmeter to J901 pin 3 and read the voltage.

Requirement: 8.5 V \pm 0.15 V.

If the requirement is not fulfilled check resistor R636 against the colour code of U602.

U602 colour code	R636 Value
Brown	omit
Red	270
Orange	100
Yellow	47
Green	22
Blue	6.8

Adjust the power supply voltage to 16.6 V and read the 8.5 V regulated. Compare the change in the 8.5 volt regulated to the value obtained at 13.2 V.

Requirement: \leq 50 mV

Repeat the procedure with the power supply adjusted for 10.8 V.

FREQUENCY SYNTHESIZER ALIGNMENT

Check the PROM U801, the TX mixer crystal, the RX mixer crystal, and the reference crystal and verify the frequencies and prom codes.

Mixer crystal output

Connect RF diode probe 95.0089-00 with multimeter to test point TP701. (1 V range).

Adjust L711 for maximum deflection on the multimeter.

Adjust L707 for maximum deflection on the multimeter.

Requirement: 250 mV \pm 125 mV
(corresponding to -10 dBm to -4 dBm).

Note: Be careful not to resonate L707 to the false harmonics. If in doubt consult table 1 or check the crystal oscillator output with a spectrum analyzer.

Receiver VCO

Connect the multimeter, 10 V range, to test point TP706. The synthesizer's lock signal is accessible at TP706. +8 V DC with very narrow pulses (0.1 μ sec) indicates normal locked condition. Unlocked condition is indicated by a variable duty signal or logic "Low". Select the channel whose frequency is closest to the center frequency.

Await locked condition, constant voltage.

Adjust C745 for 8 Volts on the multimeter.

Connect the multimeter to test point TP703.

Adjust C745 for a voltage corresponding to the variable divider ratio (V) as indicated by the graph fig. 1.

Requirement: The voltage shall be in the range 1.5 V to 6.5 V and not deviate from the graph by more than 20%.

Mixer Crystal Frequency

Connect coax probe 95.0179-00 to test point TP701.

Connect the frequency counter to the probe and read the frequency.

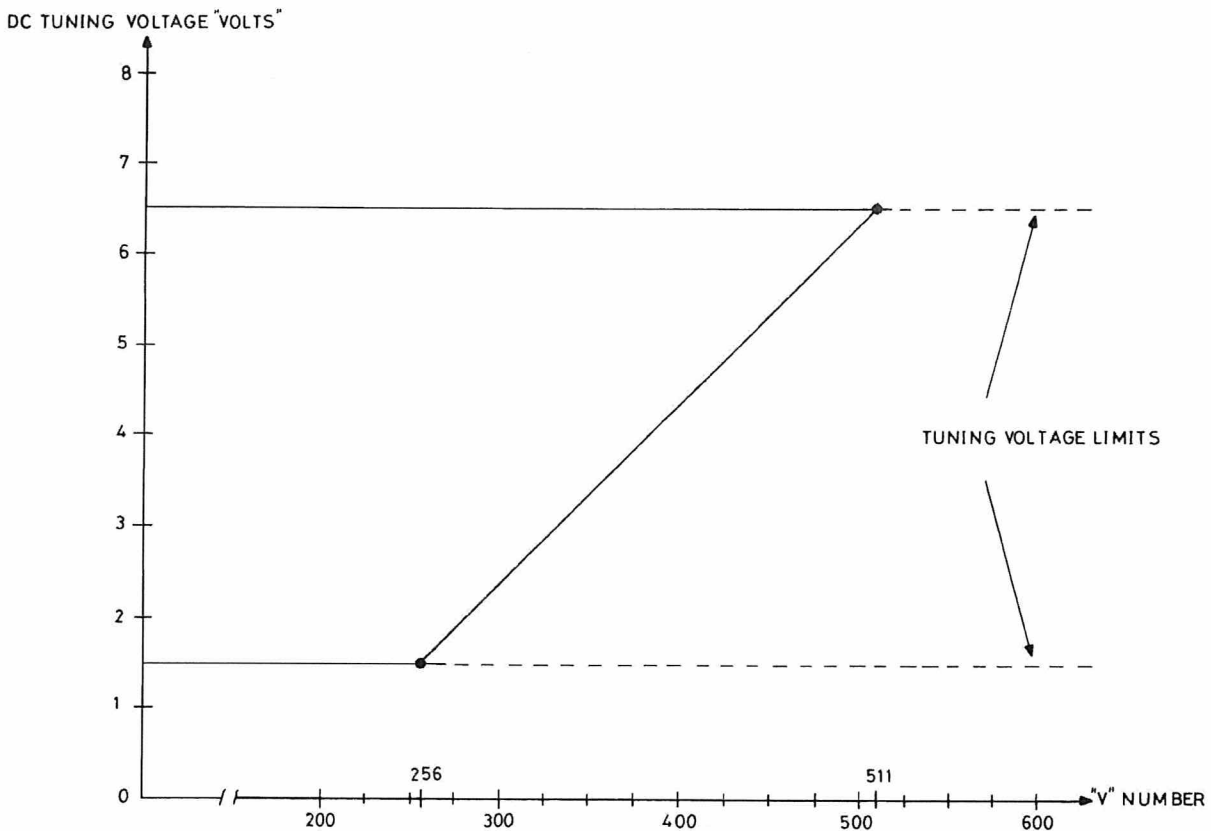

Fig. 1. Tuning voltage vs. V. number.

$$f = f_x \times 3 \quad (f_x = \text{crystal frequency})$$

Adjust L711 to the calculated frequency.

Requirement: $f \pm 0.3 \text{ ppm at } 25^\circ\text{C}$.

ppm = parts per million = 10^{-6}

Injection Frequency

Connect coax probe 95.0179-00 to test point TP401.

Connect the frequency counter to the probe.

Calculate the injection frequency for all channels.

$$f_{inj} = f_{ant} - 10.7 \text{ (MHz)}$$

Select, one by one, the channels and read the injection frequency.

Requirement: $F_{inj} \pm 0.4 \text{ ppm}$

IF AMPLIFIERS

Connect a 10.7 MHz signal generator to TP401 via coax probe 95.0179-00.

Connect RF diode probe 95.0089-00 with multimeter to test point TP501. (50 uA range).

During adjustment the RF generator output must be kept low enough to prevent limiting in the IF stages, i.e. a maximum reading of 50 uA on the multimeter.

Adjust coils L503, L502, L501, and L406, in that order, for maximum deflection on the multimeter.

FRONT-END

Connect the RF probe 95.0089-00 and the multimeter to test point TP501. (50 uA range).

Connect an unmodulated RF generator to the antenna connector, J601.

Set the generator frequency to the receiver frequency.

Adjust the generator output to produce a deflection on the multimeter, i.e. a maximum reading of 50 uA on the multimeter.

Adjust L401 and L402 for maximum deflection.

Detune L403 and 405 as much as possible.

Adjust the generator output to produce a deflection on the multimeter, i. e. a maximum reading of 50 μ A on the multimeter.

Adjust L401 and L402 for maximum deflection.

Detune L403 and 405 as much as possible.

Adjust L404 for maximum deflection on the multimeter. This is the only adjustment of L404 and it must not be touched during the rest of the procedure.

Adjust L403 and L405 for maximum deflection on the multimeter.

Readjust L401 and L402 for maximum deflection.

Remove the RF diode probe.

Standard Test condition:

Connect the RF generator to antenna connector and adjust the output to 1 mV e. m. f.

Modulate the RF generator with 1000 Hz to 60% of Δf max.

CQM5112 S12/S99	± 3 kHz
CQM5113 S12/S99	± 2.4 kHz
CQM5114 S12/S99	± 1.5 kHz

Connect a 4 ohm/3 W resistor load to connector J910/37 (SPKR HI-SPKR LO).

Connect an AF voltmeter to J910/47 (FLTD VOL SPKR LO).

IF DEMODULATOR

Turn R521 halfway up.

Adjust L504 for maximum reading on the AF voltmeter.

Connect a distortion meter and AF voltmeter and Distortion meter across the 4 ohm resistor (if Storno E11c distortion meter is used switch the function to AF voltmeter).

Adjust the volume control for approx. 2 V across the load.

Adjust L501 and L406 for minimum distortion. The demodulated signal may be monitored on an oscilloscope connected in parallel with the distortion meter.

Connect the AF voltmeter and distortion meter to J910/47 (FLTD VOL - SPKR LO).

Adjust R521 for a reading of 275 mV on the AF voltmeter.

Requirement: 275 mV \pm 5 mV.

Read the distortion.

Typical Total Harmonic Distortion (THD) will be less than 5%.

RECEIVER SENSITIVITY

EIA or CEPT method may be used.

Method of measurement CEPT

The purpose of the measurement is to define the ratio of one condition to another.

The first condition is the one where a modulated RF-signal drives the receiver into full limiting. The audio output is measured with the distortion meter (in the CAL position) and, disregarding the amplitude of the audio, this is adjusted to read 100% on the meter scale; this is our reference condition consisting of signal + noise + distortion, where 'signal' is the modulation of the RF, 'noise' is the lowest possible amount achieved from that particular receiver, when receiving a strong carrier, and 'distortion' is the modulation being slightly distorted in passing through the receiver.

The second condition is the one where the signal (modulation) is removed with a notch filter and the RF-signal is lowered in amplitude until the remaining noise and distortion increases to 20 dB below the first condition, as read on the distortion meter scale, This corresponds to a reading of 10%, 10 being 20 dB below 100, which was our reference condition.

In practice our first condition is achieved by feeding a minimum of 1000 μ V of RF signal modulated with 1000 Hz at 60% Δf max. to the receiver.

The audio output (which must be at least 100% of the receiver's audio rating) is measured through the psophometric filter, with the distort-

tion meter in position CAL and adjusted with potentiometer ADJ. FSD. to a reading of 100.

The notch filter is then inserted in series with the audio by pressing one of the buttons marked in %. The meter needle immediately drops to indicate a low value, this being the receiver's inherent audio distortion.

By backing off the attenuator of the RF-generator thereby lowering the RF-input to the receiver, the noise will eventually increase; the attenuator is now adjusted for a 10% reading on the distortion meter scale.

At this stage it must be ensured that the increased noise and the signal (with the notch filter switched out while checking) still equals 100 on the meter scale.

The RF-generator's calibrated attenuator now shows the value of RF-signal required to achieve a 20 dB ratio between signal + noise + distortion and noise + distortion, i. e. 20 dB SINAD sensitivity.

EIA Method

EIA (Electronic Industrie's Association) Standard, definition:

The SINAD sensitivity of a receiver is the minimum input signal that will provide at least 50% of the receiver's rated audio power with 12 dB signal + noise + distortion to noise + distortion.

The EIA method differs from CEPT by omitting the psophometric filter, adjusting the RF generator for $2/3 \times \Delta f_{max}$, and measure at 50% of the receiver's rated AF power. The SINAD sensitivity is measured as a 12 dB ratio between signal + noise + distortion and noise + distortion, which corresponds to a reading of 25% noise + distortion.

ADJUSTING THE SENSITIVITY

Lower the RF generator output to obtain 20 dB SINAD (10% THD as measured with the distortion meter). Readjust L402 for the best SINAD value, e. i. lowest generator output for 25% THD.

MEASURING 20 dB SINAD (CEPT)

Adjust the volume control for 2.45 V as measured with an AF voltmeter across the load.

Adjust the RF generator output to obtain 20 dB SINAD condition.

Read the 20 dB SINAD sensitivity

Requirement: $\leq 0.75 \text{ uV}$ (e. m. f.)

The sensitivity should be measured on all channels, if more than one.

MEASURING 12 dB SINAD (EIA)

Adjust the volume control for 2.45 V as measured with an AF voltmeter across the load. Adjust the RF generator to obtain 12 dB SINAD condition. Read the 12 dB SINAD sensitivity.

Requirement: $\leq 0.4 \text{ uV}$ ($\frac{1}{2}$ e. m. f.)

The sensitivity should be measured on all channels, if more than one.

AUDIO FREQUENCY RESPONSE

Set the signal generator to Standard Test Condition.

Adjust the volume control for 0.82 V across the load. (4 ohm across SPKR HI - LO).

At 13.2 V supply, $\Delta F = 60\% \Delta F_{max}$ and 1000 Hz measure the output voltage according to the following table:

	Frequency	Level	Tol.
Type CQM5112 S12	300 Hz	+9 dB	+1 dB/-3 dB
	1000 Hz	0 dB	
	3000 Hz	-9.5 dB	+1 dB/-3 dB
Type CQM5113 S12	300 Hz	+10.5 dB	+1.5 dB/-3 dB
	400 Hz	+8 dB	+1.5 dB/-1.5 dB
	1000 Hz	0 dB	
	2700 Hz	-8.6 dB	+1.5 dB/-1.5 dB
	3000 Hz	-9.5 dB	+1.5 dB/-3 dB
	6000 Hz	<-20 dB	
Type CQM5114 S12	300 Hz	+9 dB	+1 dB/-3 dB
	1000 Hz	0 dB	
	2550 Hz	-8 dB	+1 dB/-3 dB

SELF QUIETING CHECK

Internal oscillators, dividers and the harmonic frequencies hereof, may cause self quieting of the receiver if a mixer product falls in the RF or IF pass band.

For proper operation of the squelch all channels must be checked for the self quieting phenomenon.

Connect the RF generator to the antenna connector. Reduce the RF output to 0.

Set the frequency outside the 145 - 175 MHz band.

Alternatively, an attenuator (50 ohm) may be connected to the antenna connector.

Connect an AF voltmeter across the 4 ohm speaker load.

Adjust the volume control for 774 mV (0 dBm) as read on the AF voltmeter.

Select, in turn, all allocated channels.

The reading on the AF voltmeter shall not on any selected channel decline more than 6 dB.

Requirement: Quieting ≤ 6 dB.

AF POWER OUTPUT

Adjust the RF signal generator to Standard Test Condition.

Set the supply voltage to 13.2 V.

Adjust the volume control for 3 W output (3.46 V across the 4 ohm load).

Measure the distortion (THD).

Requirement: THD $\leq 5\%$.

SQUELCH

Release the squelch cancel button.

Adjust potentiometer R607 squelch adj. to open the receiver for an RF input signal corresponding to 8-10 dB SINAD.

The final squelch adjustment must not be set on a channel that has shown a minor degree of self quieting.

CURRENT CONSUMPTION

Measure the current consumption at 13.2V.

For sets with selective calling facilities add current consumption of the tone unit to the figures.

Requirements

Condition	Current consumption
Standby	≤400 mA
Receive 2 W AF ~2.83 V r. m. s. across 4 ohm.	≤750 mA

TRANSMITTER ADJUSTMENT

Adjust the power supply voltage to 13.2 V and set current limiter as follows:

25 W transmitter: 6 A
10 W transmitter: 4 A

Refer to Receiver Alignment for measuring 8.5 V regulated supply.

Preset all transmitter tuning slugs, L153, L204, L205, L208, and L209, to be flush with the coil form top.

Turn the power control potentiometer, R215, to minimum, anticlockwise (CCW).

Connect a Wattmeter, (25 W) to the antenna connector, J601.

FREQUENCY SYNTHESIZER ALIGNMENT

Check the PROM U801, the TX mixer crystal, the RX mixer crystal, and the reference crystal and verify the frequencies and the prom codes.

Mixer crystal output

Connect RF probe 95.0089-00 with multimeter to test point TP701 (1 V range).

Key the transmitter.

Adjust L701 for maximum deflection on the multimeter.

Adjust L704 for maximum deflection on the multimeter.

Requirement:

250 mV ± 125 mV

(corresponding to -10 dBm to -4 dBm)

Note: Be careful not to resonate L704 to the false harmonics. If in doubt consult table 1 or check the crystal oscillator output with a spectrum analyzer.

Transmitter VCO

Connect the multimeter, 10 V range, to test point TP706.

The synthesizer's lock signal is accessible at TP706 and +8 V DC with very narrow pulses (0.1 μ sec.) indicate normal locked condition. Unlocked condition is indicated by a variable duty signal or logic "LOW".

Select the channel whose frequency is closest to the center frequency. Key the transmitter. Await locked condition.

Adjust C737 for 8 Volts on the multimeter.

Connect the voltmeter to test point TP703.

Adjust C737 for a voltage corresponding to the variable divider ratio (V) as indicated by the graph fig. 1.

Requirement: The voltage shall be in the range 1.5 V to 6.5 V and not deviate from the graph by more than 20%.

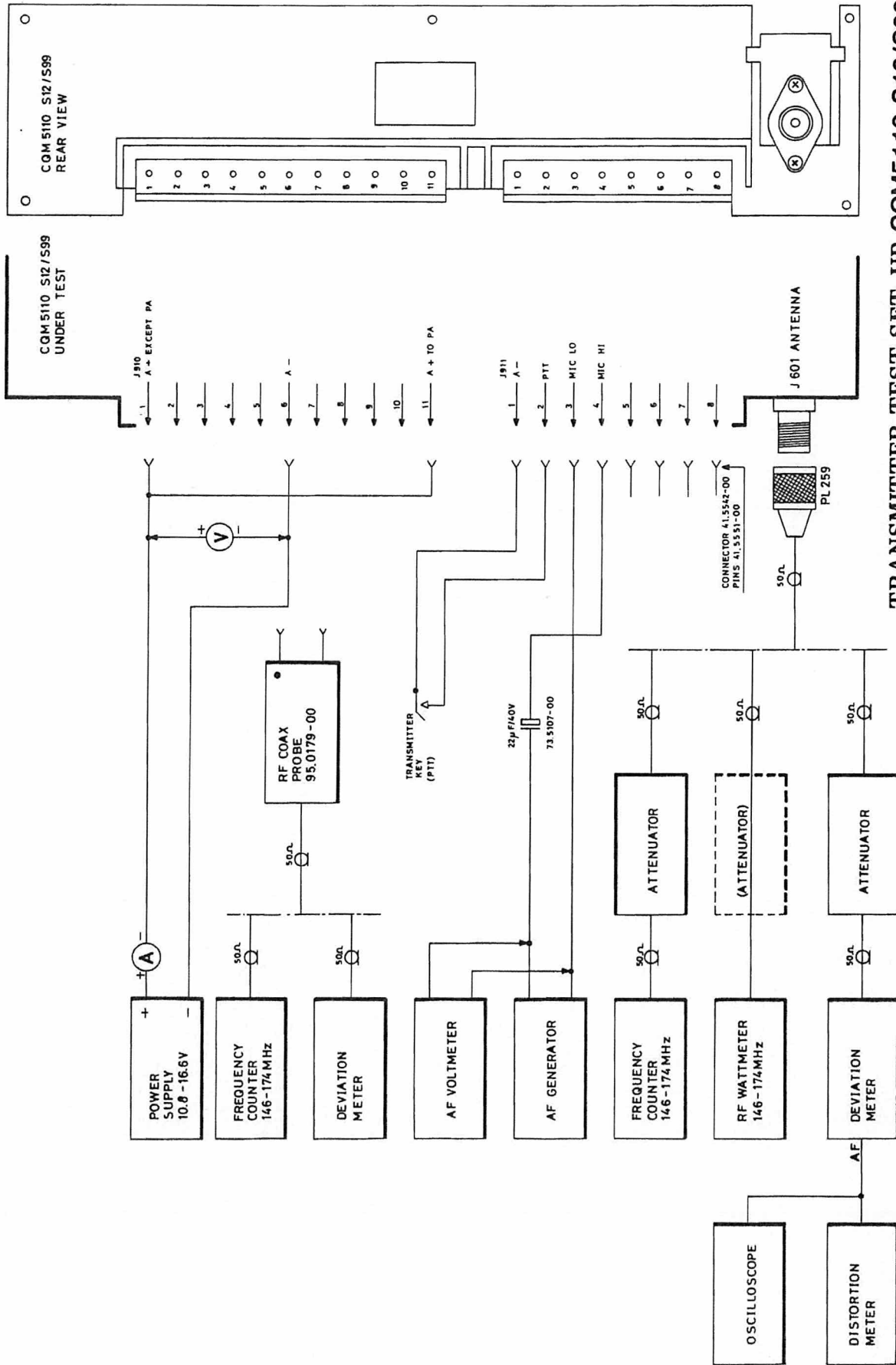

TRANSMITTER TEST SET -UP CQM5110 S12/S99

D402.877/2

Synthesizer Output Level

Connect a multimeter, 2.5 V range, to test point TP201. Key the transmitter.

Adjust L153 for maximum deflection on the multimeter, typical more than 0.75 V.

EXCITER

Coarse adjustment

Connect a multimeter (2.5 V range) to test point TP201. Key the transmitter. Adjust L153 for maximum deflection.

Adjust L204 for minimum deflection. The dip is small and careful tuning is required.

Connect the multimeter (1 V range) to test point TP202.

Adjust L205 for maximum deflection on the multimeter, typical 0.4 V.

Adjust L208 for minimum reading. The dip is small and careful tuning is required.

Connect diode probe 95.0089-00 and the multimeter to test point TP203.

Adjust L209 for maximum reading on the multimeter, typical 10 V.

Adjust the PA power control, R215, for rated transmitter power, 6/10 W or 25 W.

Fine adjustment

Connect the multimeter to test point TP201.

Key the transmitter.

Readjust L153 for maximum reading.

Connect the multimeter to test point TP202.

Peak L204 and L205 for maximum reading.

If the maximum is not well defined detune L153 slightly, adjust L204 and L205, and repeat the adjustment of L153.

Connect the 95.0089-00 RF probe and multimeter to test point TP203.

Peak L208 and L209 for maximum reading.

TRANSMITTER FREQUENCY ADJUSTMENT

Connect a frequency counter through a suitable attenuator to the antenna connector J601.

Key the transmitter.

Select, one by one, the channels and read their frequencies.

Adjust L701 for best frequency tracking on all channels.

Requirement: $F = F_{ant} \pm 0.4 \text{ ppm}$.
ppm = parts per million = 10^{-6} .

RF POWER OUTPUT, CURRENT CONSUMPTION AND POWER CONTROL

Connect the Watt meter to the antenna connector, J601.

Increase the supply voltage to 16 V. The voltage is measured directly at the input connector J910.

Readjust the PA power control, R215, for rated transmitter power (P), 6/10 or 25 W.

Requirement: $P_{nom} \pm 0.1 \text{ dB}$.

Measure the RF power output at 16 V, 13.2 V and 10.8 V.

Requirements (25 W):

Voltage	Power	Current	
		S12	S99
16.6 V	25 W (ref)	$\leq 5.8 \text{ A}$	$\leq 6.6 \text{ A}$
13.2 V	$\geq 23 \text{ W}$	$\leq 5.8 \text{ A}$	$\leq 6.6 \text{ A}$
10.8 V	$\geq 16 \text{ W}$	$\leq 5.8 \text{ A}$	$\leq 6.6 \text{ A}$

Requirements (10 W):

Voltage	Power	Current	
		S12	S99
16 V	10 W (ref)	$\leq 3.2 \text{ A}$	$\leq 3.7 \text{ A}$
13.2 V	$\geq 9 \text{ W}$	$\leq 3.2 \text{ A}$	$\leq 3.7 \text{ A}$
10.8 V	$\geq 8 \text{ W}$	$\leq 3.2 \text{ A}$	$\leq 3.7 \text{ A}$

Requirements (6 W):

Voltage	Power	Current	
		S12	S99
16 V	6 W (ref)	$\leq 2.6 \text{ A}$	$\leq 3.1 \text{ A}$
13.2 V	$\geq 5.5 \text{ W}$	$\leq 2.6 \text{ A}$	$\leq 3.1 \text{ A}$
10.8 V	$\geq 5.2 \text{ W}$	$\leq 2.6 \text{ A}$	$\leq 3.1 \text{ A}$

MODULATION ADJUSTMENT

Set the power supply voltage to 13.2 V.
 Select the channel having the highest frequency. Set R116 to mid-position.
 Connect coax probe 95.0179-00 to test point TP701.
 Connect a deviation meter to the coax probe.
 Connect a distortion meter and oscilloscope to the deviation meter output.

Connect an AF generator and an AF voltmeter to the microphone input via a 22 μ F capacitor; refer to test setup.

Set the AF generator to 1000 Hz.
 Adjust the AF generator output to 1 V r. m. s. This voltage is approx. 20 dB above the nominal modulation input level (60% Δf max) to ensure full limiting in the modulation processor.

Note the deviation read at TP701.

Connect the deviation meter to test point TP702.

Adjust R752 (Dev. Bal.) for same deviation as measured at TP701.

Connect the deviation meter through an attenuator to the antenna connector, J601.

Connect a distortion meter and oscilloscope to the deviation meter output.

Connect an AF generator and an AF voltmeter to the microphone input via a 22 μ F capacitor; refer to test setup.

Set the AF generator to 1000 Hz.
 Adjust the AF generator output to 1 V r. m. s. This voltage is approx. 20 dB above the nominal modulation input level (60% Δf max) to ensure full limiting in the modulation processor.

Find the AF frequency between 200 Hz and 3000 Hz giving the greatest frequency deviation as read on the deviation meter with the transmitter keyed.

Check the maximum deviation for both positive and negative deviation polarity. At that audio frequency set the maximum frequency deviation Δf max with R116.

Type	Channel spacing	Δf max
CQM5112 S12	30/25 kHz	± 5 kHz
CQM5113 S12	20 kHz	± 4 kHz
CQM5114 S12	12.5 kHz	± 2.5 kHz

Requirement

Difference between + and - deviation: $\leq 10\%$

MODULATION SENSITIVITY AND MODULATION DISTORTION

Set the AF generator frequency to 1000 Hz
 Adjust the generator output until 60% of Δf max is obtained on the deviation meter.

CQM5112 S12 : ± 3.0 kHz

CQM5113 S12 : ± 2.4 kHz

CQM5114 S12 : ± 1.5 kHz

Read the AF generator output and measure the modulation distortion on the audio output of the deviation meter.

Requirements:

Modulating signal: 75 mV ± 3 dB

Distortion: $\leq 7\%$
 (measured without deemphasis)

MODULATION FREQUENCY RESPONSE

Set the AF generator to 1000 Hz.
 Reduce the AF generator output until a deviation of $0.2 \times \Delta f$ max is obtained on the deviation meter.

CQM5112 S12 : ± 1.0 kHz

CQM5113 S12 : ± 0.8 kHz

CQM5114 S12 : ± 0.5 kHz

Vary the frequency of the generator and note the deviation changes as referred to the 1000 Hz value.

Requirement :

Within the frequency range 400–2700 Hz the frequency characteristic shall lie within

+1 dB/-1.5 dB related to a 6 dB/octave characteristic.

With 6 kHz modulation frequency the deviation shall be attenuated at least 6 dB below the 1 kHz value.

ADJUSTMENT OF TONE EQUIPMENT

Measuring equipment

Tone Test Generator Storno TS-G13
95B0251-00

Check the connections and the tone combination of the TQ5001/TQ5002/TQ5004/TQ5005 and SU/5002; refer to description and diagrams.

Adjustment of frequency deviation

Apply Standard test condition to the transmitter; refer to transmitter test setup.

Establish a shortcircuit between emitter and collector of Q108, on the solderside of the TQ unit, which will produce a continuous tone to the modulator.

Key the transmitter using the tone button.

Adjust R113, TQ5001/TQ5002/TQ5004/TQ5005 for 70% of maximum frequency deviation.

Remove the short circuit.

Connect the G13 Tone Test set to the AF output on the Deviation Meter.

Check that the tone call is properly received when the tone button is depressed.

Checking the Tone Receiver

Apply Standard test condition to the receiver; refer to receiver test setup.

Modulate the signal generator with the G13 Tone Test Set.

Set the G13 to the proper tone combination.

Check that the TQ unit responds to a released tone call.

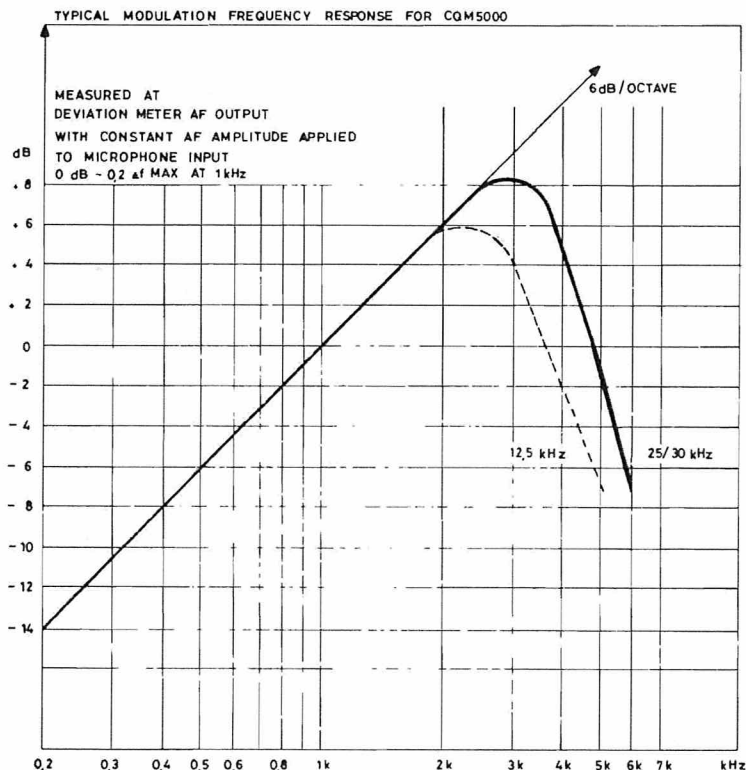

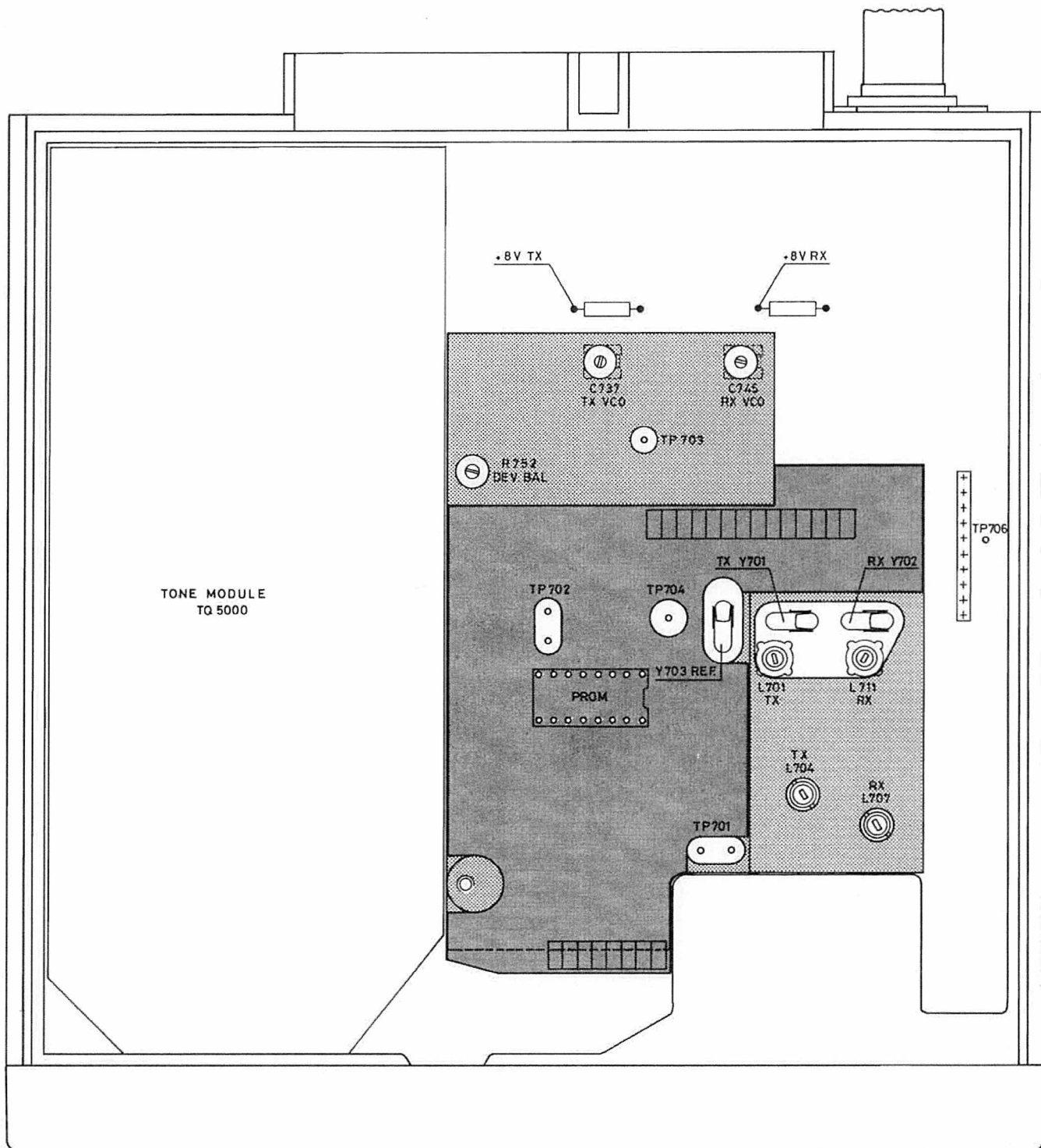

ADJUSTABLE COMPONENTS AND TEST POINTS ON CQM5000XXS12

D402.875

TECHNICAL SPECIFICATIONS

CQM5110SxxS99

Guaranteed performance specifications unless otherwise noted.

Typical values are given in brackets.

GENERAL

Frequency Range

146 - 174 MHz

Channel Separation

CQM5112: 30/25 kHz

CQM5113: 20 kHz

CQM5114: 12.5 kHz

Maximum Frequency Deviation

CQM5112: ± 5 kHz

CQM5113: ± 4 kHz

CQM5114: ± 2.5 kHz

Modulation Frequency Range

CQM5112: 300 - 3000 Hz

CQM5113: 300 - 3000 Hz

CQM5114: 300 - 2550 Hz

Maximum RF Bandwidth

RX: 1.5 MHz

TX: 2.5 MHz

Antenna Impedance

50 ohm

Maximum Number of Channels

99

Supply Voltage

Minimum : 10.8 V

Nominal : 13.2 V

Maximum : 16.6 V

Negative potential to chassis

Temperature Range

-30°C to $+60^{\circ}\text{C}$

Dimensions

B x D x H: 180 x 90 x 60 mm

Weight

1.8 Kg

RECEIVER

Sensitivity

12 dB SINAD (EIA), $\frac{1}{2}$ e.m.f.

0,4 μV (0,3 μV)

60% Δf_{max} ; $f_{\text{mod}} = 1$ kHz

20 dB SINAD (CEPT) e.m.f.

CQM5112: 0.75 μV (0.55 μV)

CQM5113: 0.75 μV (0.55 μV)

CQM5114: 1.0 μV (0.75 μV)

60% Δf_{max} ; $f_{\text{mod}} = 1$ kHz.

Measured with psophometric filter.

Crystal Frequency Range

43 - 53 MHz

Receiver VCO Frequency Range

135 - 163 MHz

Frequency Stability

Conforms with governments regulations

Modulation Acceptance Bandwidth (EIA)CQM5112: ± 7 kHz (± 7.5 kHz)Adjacent Channel Selectivity

EIA

CQM5112: 75 dB (87 dB)

FTZ

CQM5113: 67 dB (70 dB)

CEPT

CQM5112: 75 dB (87 dB)

CQM5114: 65 dB (85 dB)

Spurious Rejection EIA

80 dB (85 dB)

Intermodulation Attenuation

EIA

CQM5112: 70 dB (72 dB)

CEPT

CQM5112: 70 dB (75 dB)

CQM5113: 70 dB (75 dB)

CQM5114: 70 dB (73 dB)

FTZ

CQM5113: 70 dB (72 dB)

Blocking

90 dB/uV (104 dB/uV)

Radiation

Conducted: max 0.8 nW

Radiated: max. 0.8 nW

AF Load Impedance (Loudspeaker)

4 ohm

AF Power Output

3 W (3.6 W)

AF Distortion

5% (1.5%)

60% Δf max., 1 kHz, 1 W, RF 1 mWModulation Response

CQM5112

300 - 3000 Hz (CEPT)

+1/-3 dB (+0.5/-2 dB)

relative to 1000 Hz, 6 dB/octave

CQM5113

400 - 2700 Hz (CEPT/FTZ)

+1/-1.5 dB (+0.5/-1 dB)

300 - 400 Hz

2700 - 3000 Hz

+1.5/-3 dB (+0.5/3 dB)

relative to 1000 Hz, 6 dB/octave

CQM5114

300 - 2550 Hz (CEPT)

+1/-3 dB (+0.5/-2 dB)

Relative to 1000 Hz, -6 dB/octave

Hum and Noise (EIA)

Squelched: 80 dB (better than 85 dB)

Unsquelched: 55 dB (57 dB)

Recovery Time

250 ms (200 ms)

Attack Time (EIA)

150 ms (110 ms)

Squelch Closing Time (EIA)

150 ms (50 ms)

Current Consumption

Squelched: 1000 mA (750 mA)

Receive; AF 2 W: 1450 mA (1150 mA)

(without tone equipment, 13.2 V supply)

TRANSMITTER

RF Power Output

CQM5110 6/10 W: 6/10 W

CQM5110 25 W: 25 W

 $R_L = 50 \text{ ohm}$ Crystal Frequency Range

47 - 56 MHz

Crystal Frequency Multiplication

x3

Transmitter VCO Frequency Range

146 - 174 MHz

Frequency Stability

Conforms with government regulations

Undersired Radiation

max. 0.2 uW

Sideband Noise Power (CEPT)

Better than 70 dB

AF Input Impedance

560 ohm

Modulation Sensitivity90 mV \pm 3 dB(60% Δf max, 1 kHz)Modulation Response

CQM5112

300 - 3000 Hz (CEPT)

+1/-3 dB (+0.5/-2 dB)

relative to 1000 Hz, 6 dB/octave

CQM5113

400 - 2700Hz (CEPT/FTZ)

+1/-1.5 dB (+0.5/-2 dB)

300 - 400 Hz

2700 - 3000 Hz

+1.5/-3 dB (+0.5/-2 dB)

relative to 1000 Hz, 6 dB/octave

CQM5114

300 - 2550 Hz (CEPT)

+1/3 dB (+0.5/-2 dB)

relative to 1000 Hz, 6 dB/octave

Modulation Distortion

fm = 1000 Hz: max. 3%

60% Δf max.

fm = 300 Hz: max. 5%

5.5% Δf max.

measured with 750 us de-emphasis

FM Hum and Noise (CEPT)

55 dB (57 dB)

(measured with 750 us de-emphasis and psophometric filter).

Current Consumption

CQM5110-6/10 W: less than 3.7/4.2 A (3/3.5 A)

CQM5110 -25 W: less than 6.6 A (5.5 A)

GENERAL DESCRIPTION

CQM5110SxxS99

The Stornophone 5000 is a mobile radiotelephone unit with self-contained controls keyboard and display.

A comparison of the various models are presented in the table below.

Although compact in size, it contains a transmitter/receiver, a microcomputer controlled synthesizer and tone equipment, optional 5-tone sequential encoder/decoder or Channel Guard, and up to 99 transmit and receive channels.

Type	CQM5112SxxS99		CQM5113SxxS99		CQM5114SxxS99	
SPEC	6/10	25	6/10	25	6/10	25
Frequency Range MHz	146 - 174		146 - 174		146 - 174	
RF Power W	6/10	25	6/10	25	6/10	25
Channel Spacing kHz	30/25		20		12.5	
Max. Number of Channels	99		99		99	

ACCESSORIES

Standard accessories include:

Mounting frame

Power cable

Fist microphone with retainer or

Fixed - mount microphone

External loudspeaker

External switches

MN5001 Mounting frame for mobile installations allowing the radio to be fixed in 36 positions. Includes a base plate with locking screw.

MN703 Desk stand for fixed installations.

MN704a Mounting frame for mobile installations and direct attachment to the vehicle.

MC5001 Fist microphone with retractable spiral cable for mobile installation.

HS5001 Retainer for MC5001.

HS5002 Retainer, with switches, for MC5001

MC704 Microphone with chockabsorbing mounting bracket for mobile installation.

MC703 Desk microphone with PTT switch for fixed installations.

MK5001 Installation kit containing connectors, power cable, fuses and fuseholders.

LS701 Loudspeaker enclosed in a plastic housing, complete with cable.

SU701 Transmitter keying switch for mounting on the steering coloumn.

SU702 Transmitter keying switch for mounting on the dashboard.

PS702 Power supply regulator for 24 V car battery installations.

PS5001 Power supply for 220 V AC mains.

MECHANICAL AND ELECTRICAL DESCRIPTION

The internal construction of CQM5000 is on an H-frame chassis with a shelf separating the receiver/transmitter (RF) printed circuit board and the various option printed boards. Front panel controls, display and keyboard are an integral part of the Control Panel.

The chassis is a die cast aluminium frame comprising the left and right sides, the back, and a shelf located midway between the top and bottom. The chassis front is open and looks like an "H" viewed from the front.

Interconnection to the package exterior and to internal options are made via the Frequency Synthesizer Board located on the option side of the H-frame. A test connector is also located on the synthesizer board and is accessible from the rear of the radio.

The moulded plastic front is directly attached to the chassis and has the speaker mounted to it. A separate moulded control panel and aluminum nameplate are attached to the front.

The top and bottom covers slides under the edge of the front and are then secured by screws at the rear.

The tone signalling encoder/decoder board (TQ), the Frequency Synthesizer Board (FB), and the Control Logic (CL) mount in the top section of the chassis.

Thin casted shields with adjustment holes are placed over the RF board and the synthesizer board in order to reduce spurious radiation.

RECEIVER DESCRIPTION

The receiver circuitry is placed on the RF board and can be divided into:

- Receiver front end
- 1st IF section with first and second oscillator
- 455 kHz 2nd IF portion with demodulator.
- Squelch
- Audio Amplifier

(refer to functional block diagram)

FRONT-END

The receiver front-end consists of a dual-resonator input filter, a transistor RF amplifier, Q401, a triple-resonator intermediate filter and a FET mixer, Q402. The drain of the FET is terminated in the first IF resonant circuit

which adapts the output impedance to the crystal filter. The front-end, antenna relay, first mixer and part of the transmitter PA interconnections are designed in micro-stripline techniques on the mainboard.

1st IF

The first IF frequency is 10.7 MHz. The output from the crystal filter is fed to a dual-gate MOSFET amplifier, Q501, the output signal of which is fed to the second mixer, U501, a single balanced, self-oscillating, active mixer. Out of the second mixer comes the 455 kHz IF signal. Two diodes, D501-502, limit the output from the mixer.

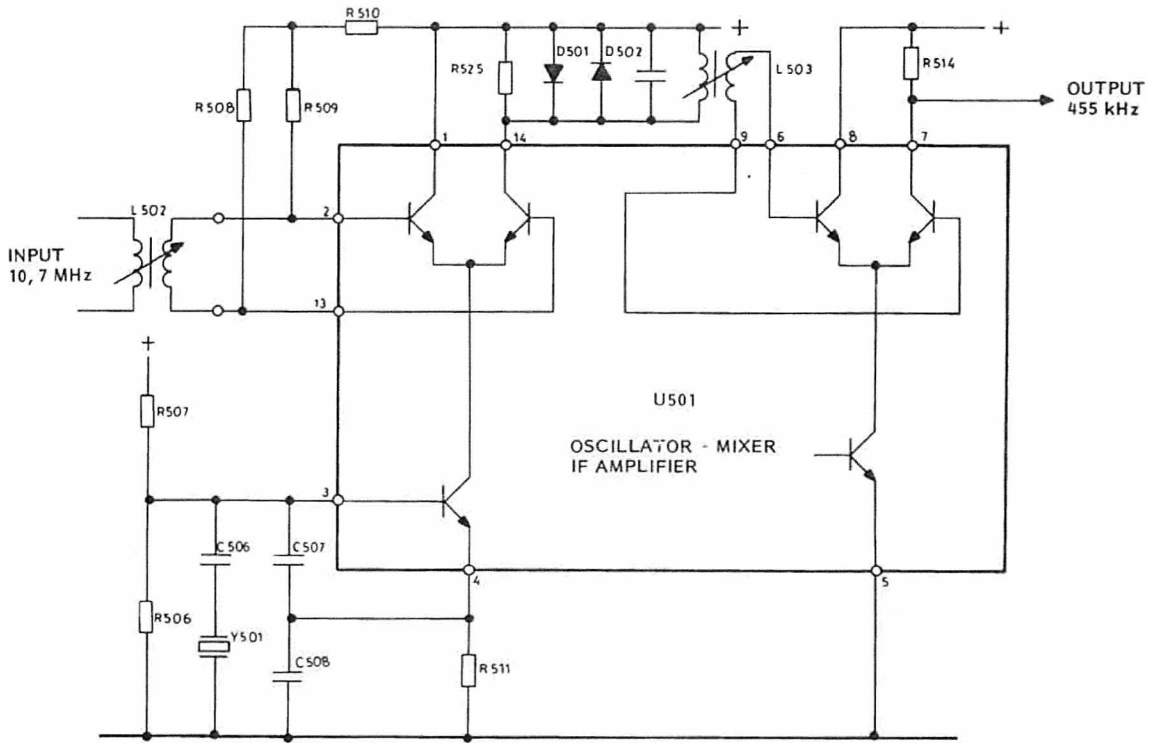

FIG. 1. SECOND OSCILLATOR , IF MIXER , AND IF AMPLIFIER

455 kHz IF/DEMODULATOR

The selectivity of the 455 kHz IF amplifier is formed by a ceramic filter fed from a 455 kHz amplifier/impedance transforming stage. The

final 455 kHz amplification and limiting is performed by an integrated circuit , U502, which also contains the quadrature FM detector and the AF amplifier/output emitter follower for the audio line signal.

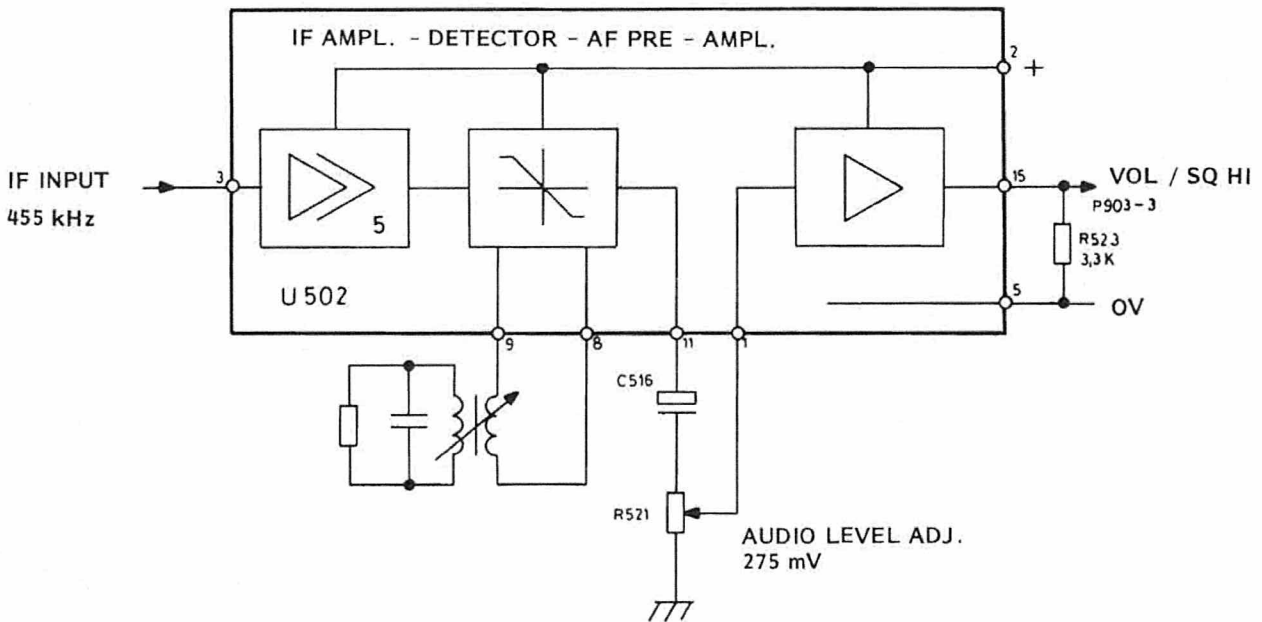

FIG. 2. IF AMPLIFIER , DETECTOR , AND AF PREAMPLIFIER

SQUELCH AND AUDIO CIRCUITS

The audio line signal (Vol/Sq - HI) is fed to a selective amplifier stage, where noise (frequencies around 8 kHz) is extracted from the audio signal. Via the squelch potentiometer R607, this signal reaches an expander stage which improves the level discrimination characteristics of the circuit. A passive voltage doubler circuit (D603-D604) with high source impedance performs the action of an average value rectifier. A Schmitt Trigger gives the necessary hysteresis and a well-defined output from the following buffer stage, Q605.

In the squelched condition and during transmissions this output is +1.5 V and mutes the audio power amplifier. The transmit indicator is part of the muting function.

A push button switch, S601, cancels the squelch function, when depressed, by grounding the base of Q601.

AUDIO

In sets with Pilot tone option (CG), the audio line signal is fed to the Pilot tone board for filtering and back to the main board. In sets

without CG this path is bypassed and the audio line signal is fed directly to the passive deemphasis network R629-C608 followed by the volume control. The volume control potentiometer R630 is mounted directly on the RF board and protrude through the front panel. The audio output amplifier U601 is a monolithic IC package capable of driving the loudspeaker at the desired power level. The output amplifier can be muted with a DC signal from the audio mute gate, which combines different logic signals to decide whether the amplifier should be active or not. These inputs are:

- Regulated TX Voltage
- Squelch cancel
- Squelch signal

In sets equipped with Pilot tone and/or 5-tone sequential option, an RX mute function is routed from the option board to make the extra mute conditions possible. The value of C610 in the feed back loop is chosen as the best compromise between battery ripple rejection and receiver squelch attack time.

The pilot lamp in the channel knob is supplied from A+, but controlled by the regulated 8.5 V via transistor Q968.

TRANSMITTER

The transmitter consists of a modulation processor, an exciter, and a power amplifier, all assembled on the RF board along with the receiver.

The exciter contains, an audio processor, all frequency multiplier functions, and includes those stages operating at low enough power levels to avoid heat sinks. The exciter output is at the carrier frequency when applied to the power amplifier. The power amplifier boosts the signal to the proper level, and includes a low pass filter for suppressing harmonics and a circuitry which permits adjustment of the operating power level. The PA

low pass filter connects to the antenna relay via a stripline on the board.

MODULATION PROCESSOR

The signal from the microphone load R901 on the FS board is applied to amplifier U101b. The transmitter audio frequency response is shaped by the feedback network R104-R103-C104.

The modulation limiting is obtained in the feedback network formed by D101, D102, R105, R106 and R107. The maximum permissible frequency deviation is set by a DEV. BAL. po-

tentiometer on the FS board.

Amplifier U101A is operated as an active low-pass splatter filter feeding the modulating input of the VCO on the Frequency Synthesizer board.

EXCITER

The exciter takes the synthesized signal, filters it to reduce spurious signals and amplifies it. Four amplifier stages (Q201-2-3-4) and four filters (L204-5-8-9) are used in a narrow band design which limits the maximum frequency spread of the transmitter. The exciter has three test points (TP201-2-3) for measurements and alignment.

POWER AMPLIFIER

The PA is constructed on the main board and employs two broadband untuned amplifier stages Q205, Q206. Two amplifier configurations are available providing options of power levels of 10 watts or 25 watts. A power control circuit is included to sense the output RF level and keep it constant with variations in temperature and supply voltage. This circuit also limits the peak power to less than maximum, as specified by the authorities, while still maintaining the output as near maximum as possible. The output power level can be set with a potentiometer, R215, over at least a 3:1 range. The transmitter delivers rated power into a 50-ohm load. A load SWR of 1.4:1 will result in more than 90% of the power being radiated. The transmitter will operate into a load with up to 3:1 SWR.

The power adjustment is achieved by controlling the supply voltage of power amplifier Q205 via transistor Q207. This series transistor is biased by a voltage generated by the feedback network C255, D201, Q201, Q209, Q208.

FREQUENCY SYNTHESIZER AND CONTROL LOGIC

The frequency synthesizer FS5111 provides up to 99 channels and is built on a printed wiring board which mounts in the top section of the radioset.

The frequency of the synthesizer board is set by a binary code from the control logic board CL5001 which is placed over the main section of the synthesizer board.

The Frequency Synthesizer board also carries all interconnections between the tone modules and the RF module, and it has two connectors at the rear for accessories and the power supply cable.

SUPPLY VOLTAGE DISTRIBUTION SYSTEM

The battery voltage (A + BATT) enters the radio via two pins of the rear system connector to the synthesizer board. Both inputs are connected to reverse polarity protection diodes D741, D742. The ground lead comes through the same connector and is connected to chassis ground through a fusible printed wiring path which will open in case of the ground wire being accidentally connected to A +.

One battery input goes directly from the synthesizer board via a feed-through capacitor and a connector P907 to the transmitter PA stages. The other input feeds through P903 - J903 to the RF board for two functions. One branch for the audio amplifier passes through an RC-ripple filter R638 - C618 and one of the ON/OFF switch sections S602. The other section of the ON/OFF switch controls the $V_B +$ to the voltage regulator U602 consisting of a monolithic regulator. The regulator output is fixed at 8.5 V by means of a factory adjusted resistor.

Regulated 8.5 V is switched to either the receiver or the transmitter by the antenna relay. The antenna relay is also supplied by the 8.5 V regulated.

The squelch circuit, the modulation processor, parts of the IF amplifier U502, and the Frequency Synthesizer is supplied directly from the continuous 8.5 V.

The receiver front-end, the 10.7 MHz IF stages and the second oscillator are supplied from 8.5 V RX. The transmitter exciter is supplied from 8.5 V TX.

In sets with 5-tone sequential option or Pilot tone, the PTT (Push to talk) lead runs through the option board to provide for correct tone keying function.

WARNING

The transmitter PA transistors contain Beryllia which is poisonous when absorbed by the human body. Dissection, filing, or grinding of these transistor may be hazardous.

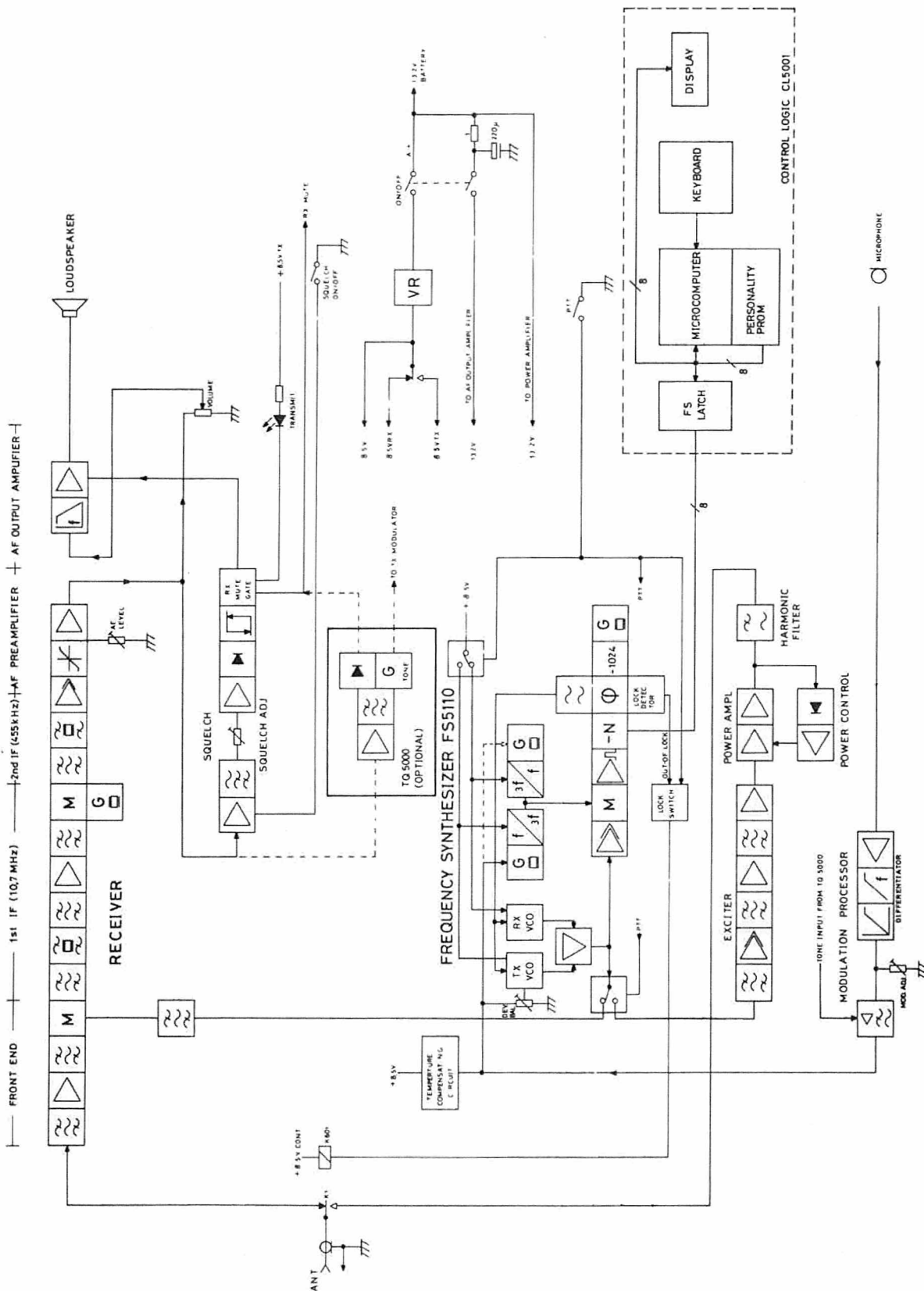

FUNCTIONAL BLOCK DIAGRAM CQM 5110 S S99

D 403.129

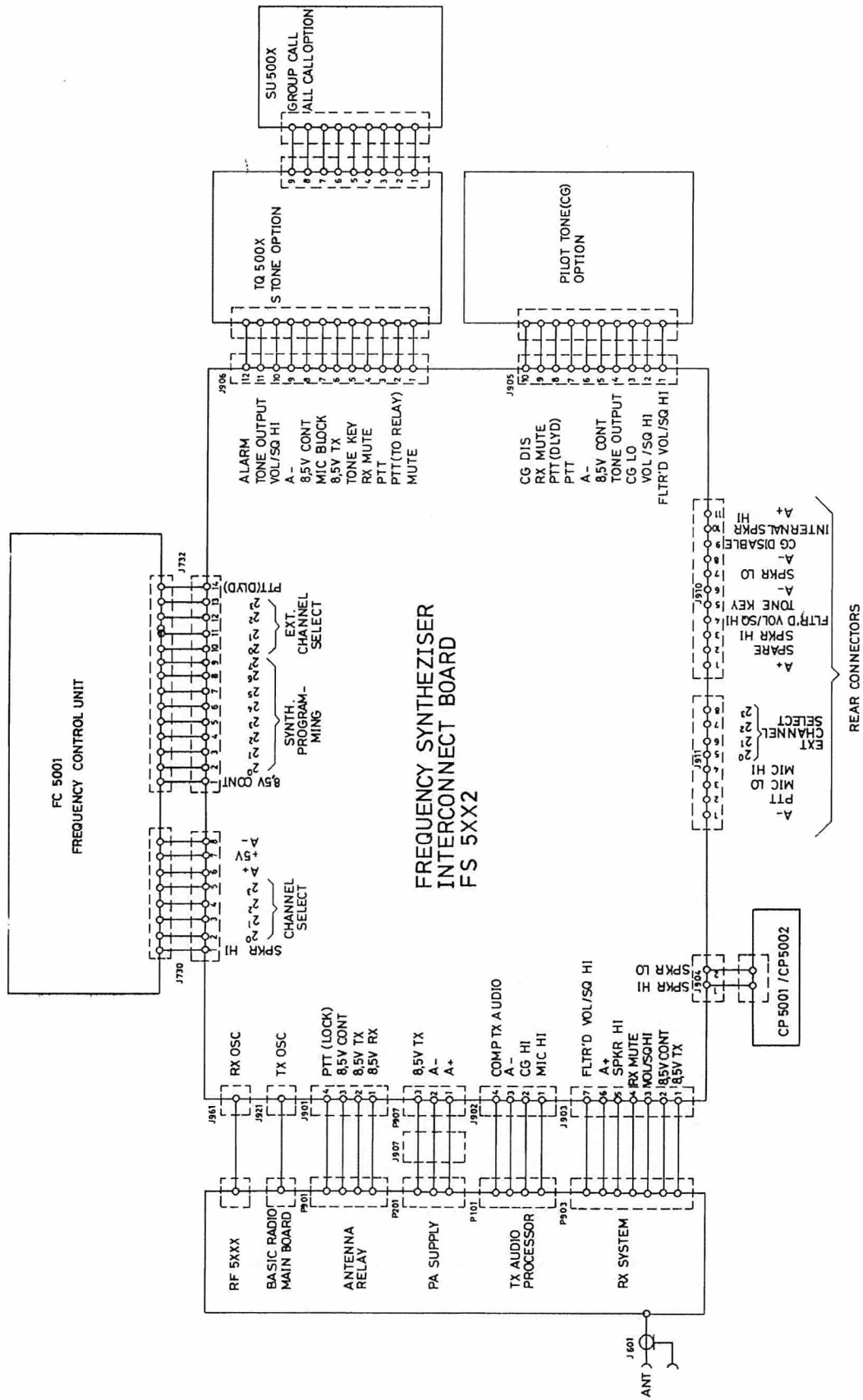

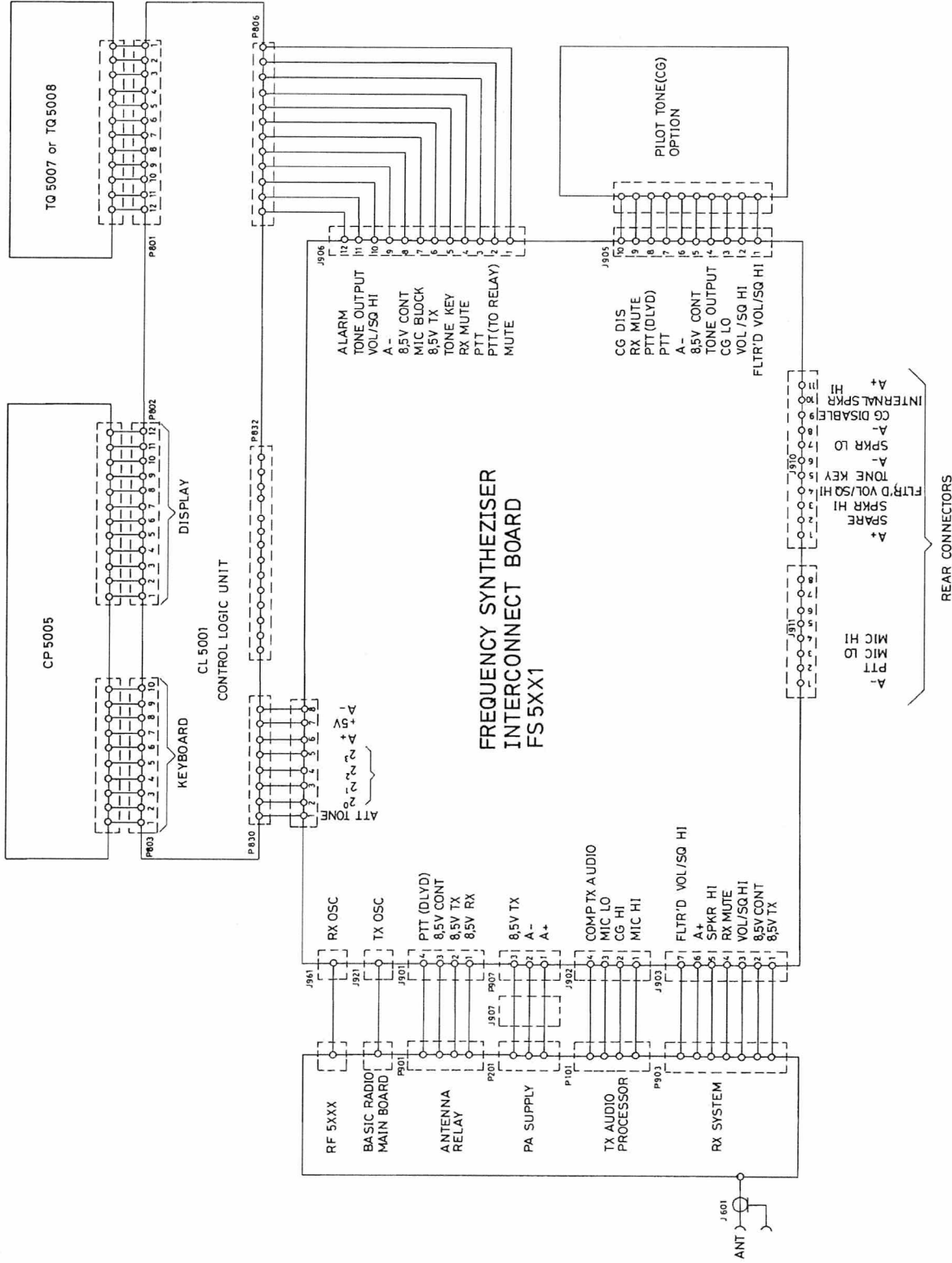

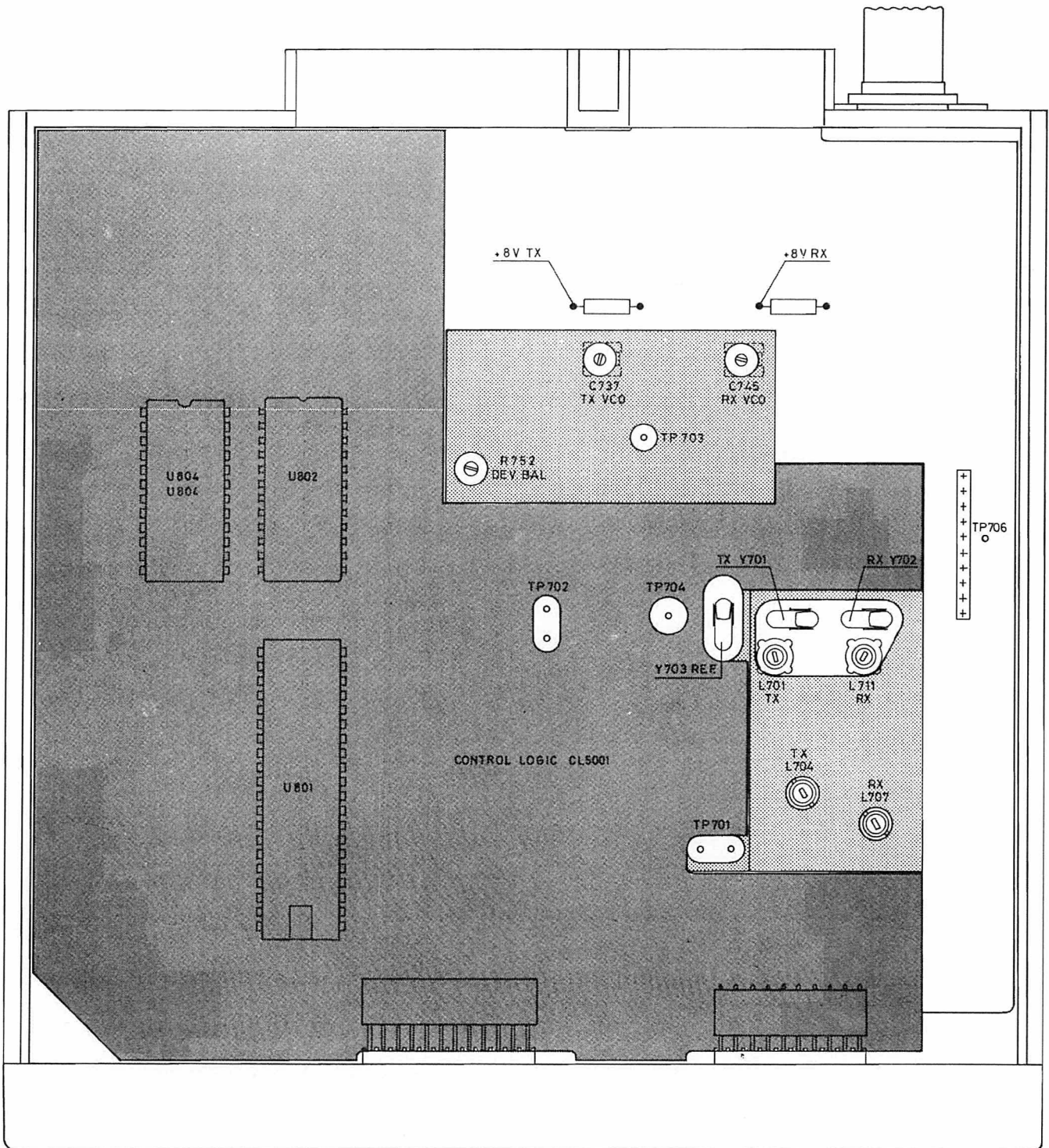

ADJUSTABLE COMPONENTS AND TEST POINTS ON CQM5000SXXS99

CHANNEL FREQUENCY SYNTHESIZER

FS5111 and FS5112

The frequency synthesizer generates up to 12 channel frequencies for a STORNOPHONE 5000 operating in the 146 - 174 MHz band. It is built on a printed circuit board which mounts in the top section of the radio set. There are two versions of the board, a single channel board, FS5111 and a multichannel board FS5112. The frequency of the single channel board is set by putting a binary code directly on the programmable divider input while the multichannel board channels are selected with a channel selector and a Frequency Control unit, FC5001. The channel selector is mounted directly on the board and protrudes through the front panel, and the Frequency Control module FC5001, fits into the cast shield which is placed over the main section of the synthesizer board. A metal shield is placed underneath the oscillator and mixer sections of the board.

All circuitry can be accessed and operated for repair and maintenance without the shields and with the FC5001 in its socket.

The Frequency Synthesizer board also carries all interconnections between the tone modules and the RF module and has two connectors at the rear for accessories and power supply cables.

The channel programming is contained in a 256 bit PROM placed in a socket on the Frequency Control module. The PROM can be field programmed if the necessary programming equipment is available. Programming equipment and procedures must be approved by STORNO and the PROM manufacturer, refer to the Channeling Instruction.

CIRCUIT DESCRIPTION

The Frequency Synthesizer generates the local oscillator injection for the receiver and a modulated exciter signal for the transmitter. The circuit is a single-loop phase-locked frequency generator.

The synthesizer frequency is controlled by three crystals, one reference crystal and two mixer crystals, and by a PROM.

The synthesizer can be reprogrammed for new frequencies if these are within the maximum frequency spread of the STORNOPHONE 5000.

Two voltage controlled oscillators (VCO) are generating the signals which are used as injection for the receiver mixer and excitation signal for the transmitter. The frequency of each VCO can be preset to any frequency

within the band by a variable capacitor, and the fine adjustment is controlled by a variable capacitance diode, varicap, and the phase detector output. The control voltage for the varicaps is filtered in a loop integrating filter. The TX VCO has an additional varicap which is used to modulate the transmitter.

The Push-to-talk switch controls a transistor switch, which switches the supply voltage between the RX VCO and the TX VCO.

The output signal from the VCOs are fed into a buffer amplifier which protects the VCO from load changes.

The buffer amplifier's output is applied to an isolation amplifier and a diode switch before entering the RF board.

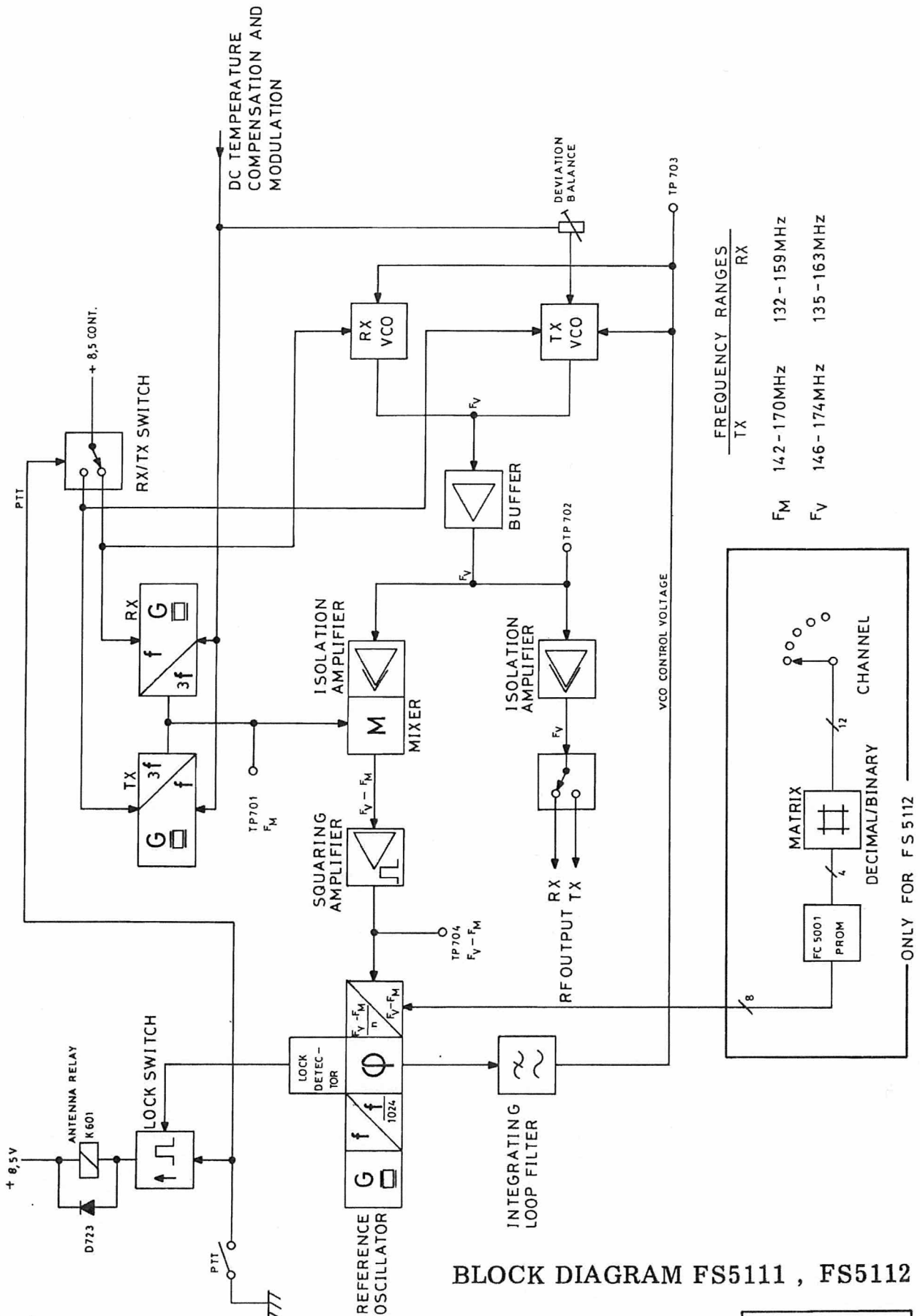

BLOCK DIAGRAM FS5111 , FS5112

D402873

Fig. 1

The buffer amplifier also connects to another isolation amplifier via a resistive attenuator and feeds the signal to the synthesizer mixer.

The synthesizer mixer mixes the VCO signal and the crystal oscillator signal to a frequency which is within the dividing capability of the programmable divider.

Separate crystal oscillators are used in the receive and transmit mode, respectively, and they are both third mode oscillators.

A temperature compensating voltage is applied to the crystal oscillators only in the 5 p. p. m. version. This voltage is kept constant in the 10 p. p. m. version by cutting a diode on the RF board.

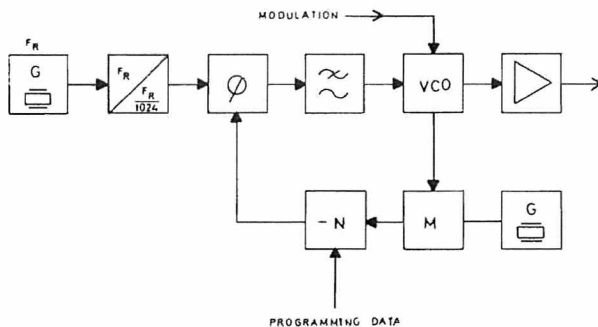

Fig. 2 Phase Locked loop Principle

The output from the synthesizer mixer is fed to a squaring amplifier which drives the programmable divider and this divides the frequency by 211 to 511 depending on the logic levels on the 8-bit binary control input. The input frequency range for the divider differs according to the channel spacing and is shown in fig. 3.

The phase detector produces a waveform with variable duty cycle which depends on the phase and frequency difference between its two input signals. The operating frequency range of the phase detector is 4 kHz to 15 kHz and it depends on the channel spacing.

The reference frequency is generated in a crystal oscillator whose output is divided by 1024 and applied to the phase detector.

The output from the phase detector passes through a passive integrating filter which produces a DC voltage proportional to the duty cycle of the phase detector output. This voltage adjusts the frequency of the VCO.

An out-of-lock circuit inhibits the transmitter when the synthesizer loop is out of lock and hunting for the frequency.

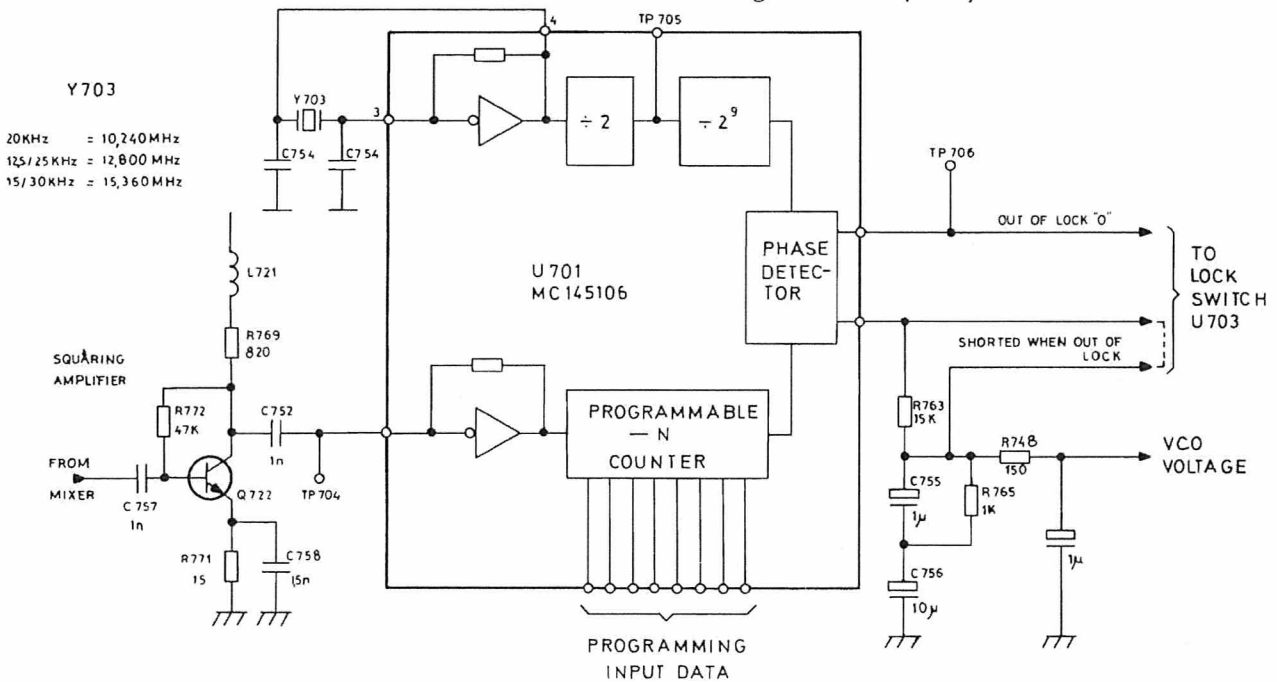

Fig. 3. REFERENCE OSCILLATOR, DIVIDER, AND PHASE DETECTOR

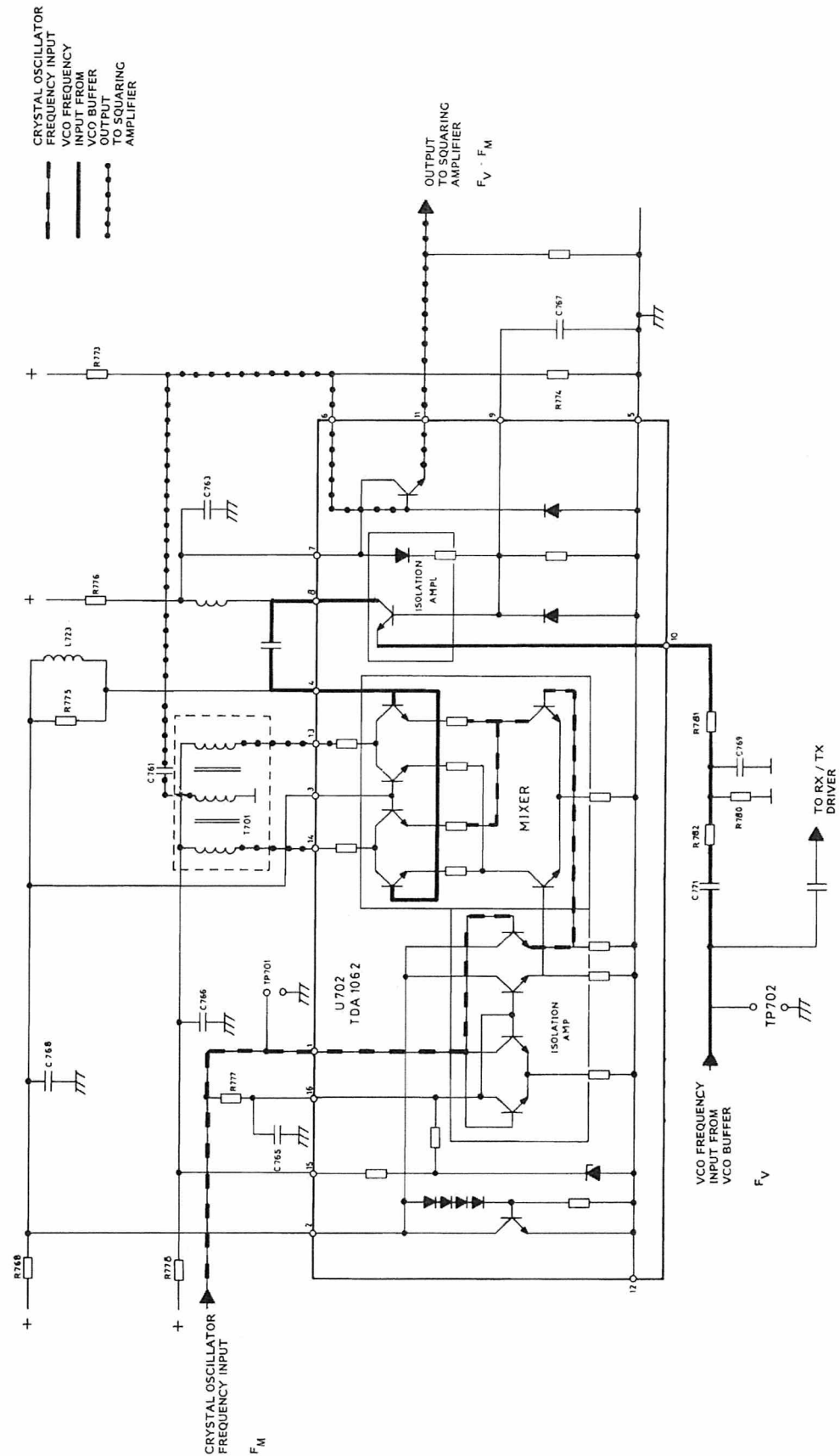

Fig 4. Synthesizer Mixer and Isolation Amplifiers, U702.

The transmitter modulation is applied simultaneously to the transmitter mixer-oscillator and the VCO. The modulation bandwidth also covers sub-audio frequencies used for channel guard (pilot tones). The frequency deviation balance adjustment equalizes the deviation on both oscillators to ascertain low distortion and low noise reference side bands during modulation of the synthesizer because it is operating with a relatively large loop bandwidth.

The frequency control module, FC5001, is built on a separate wiring board which mounts on top of the synthesizer shield. This module converts the BCD-code (4 bits) from the chan-

nel selector to an 8-bit binary code for the programmable divider in the synthesizer loop. These 8-bit codes are programmed into a PROM (Programmable Read Only Memory) and are dividing factors expressed in hexadecimal codes.

On the FC5001 is a 5-Volt regulator which supplies the voltage for the PROM. When the PTT button is pushed the transistor Q801 converts the PTT voltage level to TTL level and puts a logic "0" on the MSB (Most Significant Bit) on the address input of the PROM. This selects the PROM code for the corresponding transmitter channel. The PROM outputs have open collectors with external pull-up resistors.

TECHNICAL SPECIFICATIONS

Supply Voltage

+8.5 Volts regulated
+13.2 Volts unregulated

Current Consumption

max. 80 mA (+8.5 V)
max. 200 mA (+13.2 V)

Channel Spacing

20 kHz
12.5/25 kHz
15/30 kHz

Modulation Input

0.75 V r. m. s. ± 2 dB
 $\Delta f = 60\% f_{\text{mod}} = 1$ kHz

Modulation Bandwidth

70 - 3000 Hz

Modulation Distortion

70 - 300 Hz: <5%
1 kHz: <4%

DC Temperature Stabilization Voltage

25°C = 6 V $\pm 10\%$ (reference)
-30°C = +350 mV $\pm 10\%$
-10°C = -50 mV $\pm 10\%$
+60°C = +50 mV $\pm 10\%$

The voltage characteristic is approximately linear between these points.

RF Output Level

4 mW ± 1 mW
(open collector output connected to tuned circuit)

TX Output Frequency Range

146 - 174 MHz (VCO)

RX Output Frequency Range

135 - 163 MHz (VCO)

Frequency Stability

5 p. p. m. or 10 p. p. m.

Reference Crystal Frequency

20 kHz: 10.240 MHz
12.5/25 kHz: 12.800 MHz

Signal-to-Noise Ratio (S/N)

>100 dB

 $\Delta f = 25$ kHz, $BN = 10$ kHzSpurious Attenuation

>85 dB

Lock Time

<30 m sec.

for 1 MHz step

Logic Control Level

LOW= <2 V

HIGH= >6 V

8 bit binary positive logic with built-in pull down resistors, $I_{in} = 175$ uA per bit.Temperature range -30°C to $+60^{\circ}\text{C}$ Dimensions

135 x 190 x 45 mm (BxDxH)

Weight

PC board: 150 g

Shield: 75 g

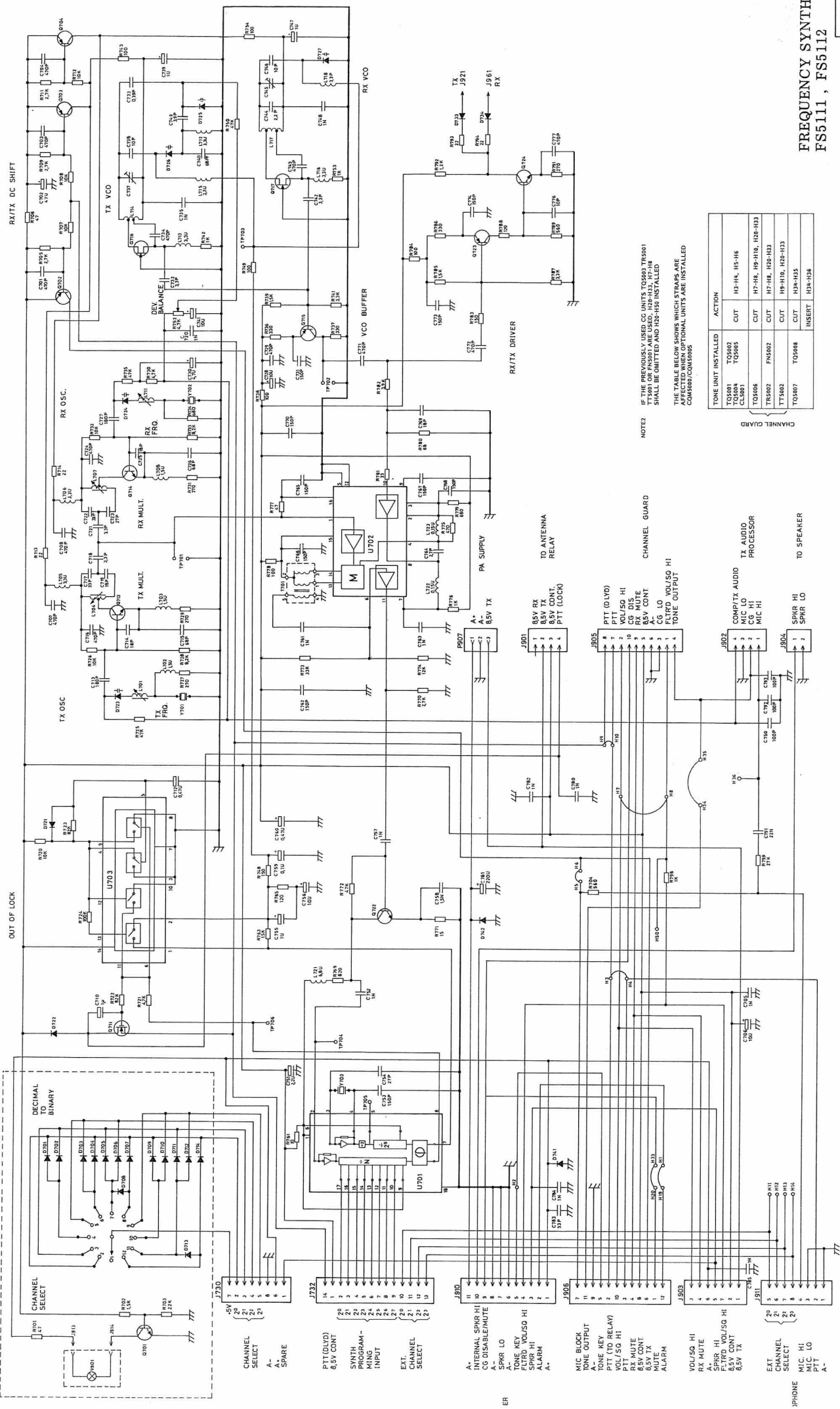

NOTE2
IF THE PREVIOUSLY USED CG UNITS TOS683 TR5801
TS1500 OR FN583 ARE USED, HSP-H33, H7-H8
SHALL BE OMITTED AND HSP-H32 INSTALLED.

THE TABLE BELOW SHOWS WHICH STRAPS ARE
AFFECTED WHEN OPTIONAL UNITS ARE INSTALLED
COM580/COM580S

TO NE UNIT INSTALLED	ACTION
TOS681	CUT
TOS682	CUT
TOS684	CUT
CL5801	CUT
TOS686	CUT
TR5902	CUT
TT5902	CUT
TOS907	CUT
TOS908	INSERT

CHANNEL GUARD

TX AUDIO

TO SPEAKER

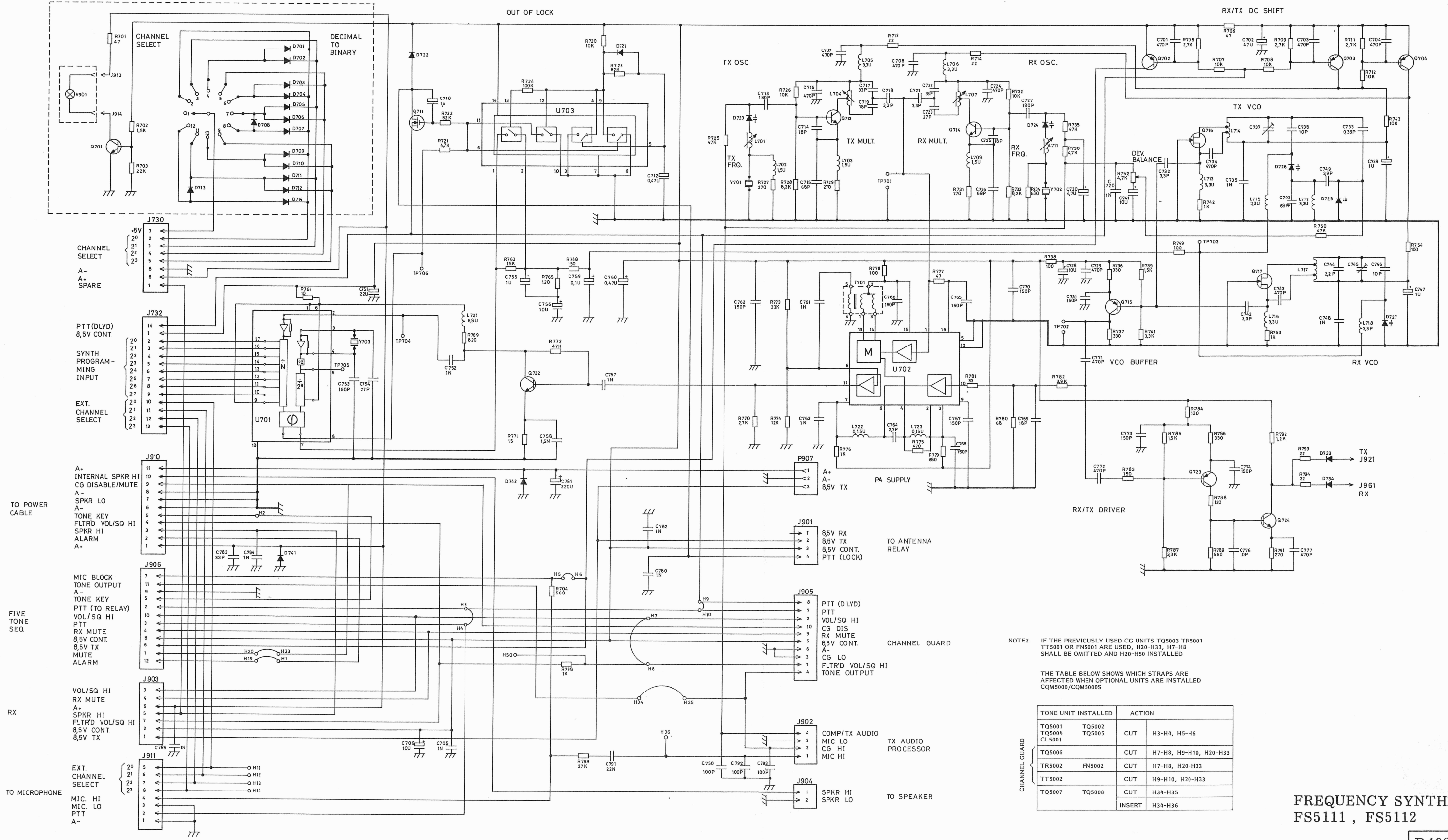

NOTE2. IF THE PREVIOUSLY USED CG UNITS TQ5003 TR5001 TT5001 OR FN5001 ARE USED, H20-H33, H7-H8 SHALL BE OMITTED AND H20-H50 INSTALLED

THE TABLE BELOW SHOWS WHICH STRAPS ARE AFFECTED WHEN OPTIONAL UNITS ARE INSTALLED CQM5000/CQM5000S

TONE UNIT INSTALLED	ACTION
TQ5001	CUT
TQ5002	CUT
TQ5004	CUT
TQ5005	CUT
CL5001	CUT
TQ5006	CUT
TR5002	CUT
FN5002	CUT
TT5002	CUT
TQ5007	CUT
TQ5008	CUT
	INSERT

FREQUENCY SYNTHESIZER
FS5111, FS5112

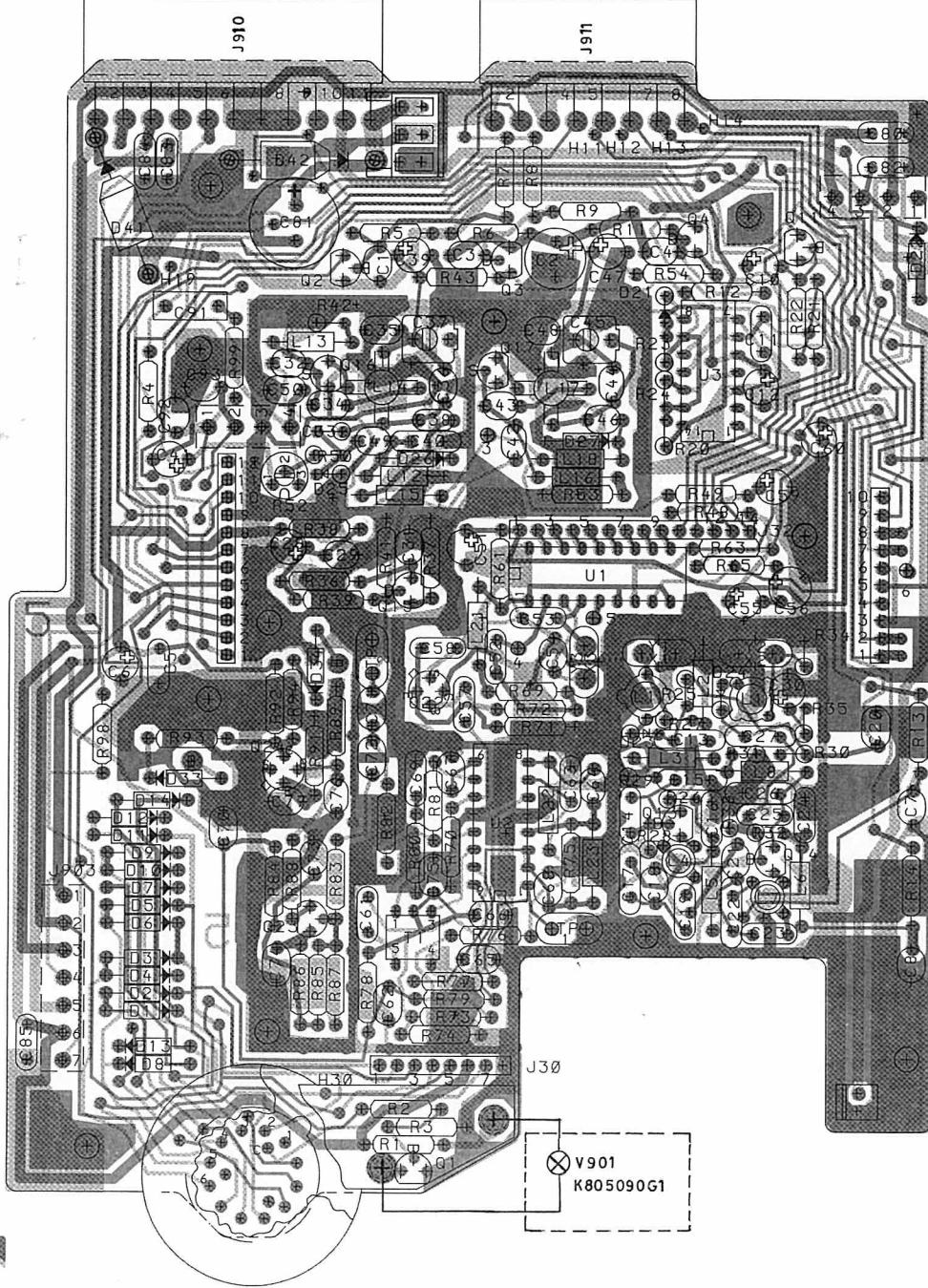

TYPE	CODE NO.
FS5331	M905054G1
FS5332	M905054G2
FS5111	M905054G3
FS5112	M905054G4
FS5661	M905054G5
FS5662	M905054G6
FS5551	M905054G7
FS5552	M905054G8

FREQUENCY SYNTHESIZER
 FS5X1.FS5XX2
 COMPONENT LAYOUT D402.886/3

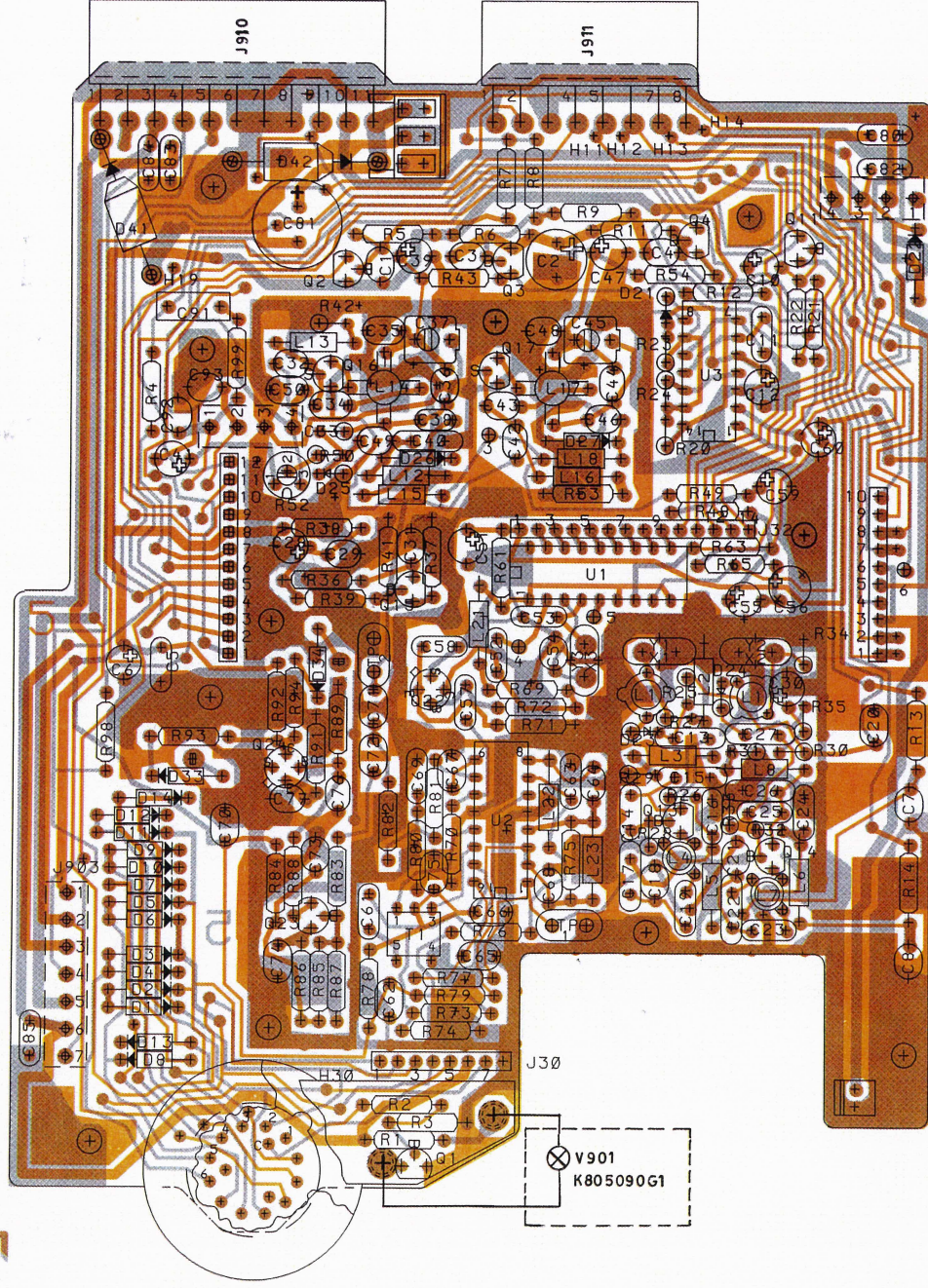

TYPE	CODE NO.
FS5331	M905054C1
FS5332	M905054C2
FS5111	M905054C3
FS5112	M905054C4
FS5661	M905054C5
FS5662	M905054C6
FS5551	M905054C7
FS5552	M905054C8

FREQUENCY SYNTHESIZER
 FS5X1.FS5XX2
 COMPONENT LAYOUT **D402.886/3**

NO	CODE	DATA
C701	A700233P5	470 pF Capacitor Ceramic
C702	J706005P3	47 uF Capacitor Electrolytic
C703	A700233P5	470 pF Capacitor Ceramic
C704	A700233P5	470 pF Capacitor Ceramic
C705	A700233P7	1 nF Capacitor Ceramic
C706	A701534P7	10 uF Capacitor Tantalum
C707	A700233P5	470 pF Capacitor Ceramic
C708	A700233P5	470 pF Capacitor Ceramic
C710	A701534P1	0.1 uF Capacitor tantal
C711	A700234P9	22 nF Capacitor Pol
C712	A701534P3	0.47 uF Capacitor Tantal
C713	A700235P28	180 pF Capacitor Ceramic
C714	J706256P202	18 pF 11500 Capacitor Ceramic
C715	J706256P205	68 pF 11500 Capacitor Ceramic
C716	A700233P5	470 pF Capacitor Ceramic
C717	A700235P19	33 pF Capacitor Ceramic
C718	A700235P7	3.3 pF Capacitor Ceramic
C719	A700235P16	18 pF Capacitor Ceramic
C720	A700233P7	1 nF Capacitor Ceramic
C721	A700235P7	3.3 pF Capacitor Ceramic
C722	A700235P19	33 pF Capacitor Ceramic
C723	A700235P18	27 pF Capacitor Ceramic
C724	A700233P5	470 pF Capacitor Ceramic
C725	J706256P202	18 pF 11500 Capacitor Ceramic
C726	J706256P205	68 pF 11500 Capacitor Ceramic
C727	A700235P28	180 pF Capacitor Ceramic
C728	A701534P7	10 uF Capacitor Tantalum
C729	A700233P5	470 pF Capacitor Ceramic
C730	A701534P6	4.7 uF Capacitor Tantalum
C731	A700233P2	150 pF Capacitor Ceramic
C732	A700235P7	3.3 pF Capacitor Ceramic
C733	A700013P8	0.39 pF Capacitor Phenolic
C734	A700233P5	470 pF Capacitor Ceramic
C735	A700233P7	1 nF Capacitor Ceramic
C737	J706003P1	1.8-10 pF Capacitor Variable
C738	A700235P13	10 pF Capacitor Ceramic
C739	A701534P4	1 uF Capacitor Tantalum
C740	A700235P23	68 pF Capacitor Ceramic
C741	A701534P7	10 uF Capacitor Tantalum
C742	A700235P7	3.3 pF Capacitor Ceramic
C743	A700233P5	470 pF Capacitor Ceramic
C744	A700235P5	2.2 pF Capacitor Ceramic

NO	CODE	DATA
C745	J706003P2	2-18 pF Capacitor Variable
C746	A700235P13	10 pF Capacitor Ceramic
C747	A701534P4	1 uF Capacitor Tantalum
C748	A700233P7	1 nF Capacitor Ceramic
C749	A700235P8	3.9 pF Capacitor Ceramic
C750	A700233P1	100 pF Capacitor Ceramic
C751	A701534P5	2.2 uF Capacitor Tantalum
C752	A700233P7	1 nF Capacitor Ceramic
C753	A700233P2	150 pF Capacitor Ceramic
C754	A700235P18	27 pF Capacitor Ceramic
C755	A701534P4	1 uF Capacitor Tantalum
C756	A701534P7	10 uF Capacitor Tantalum
C757	A700233P7	1 nF Capacitor Ceramic
C758	A700233P8	1.5 nF Capacitor Ceramic
C759	A701534P1	0.1 uF Capacitor Tantalum
C760	A701534P3	0.47 uF Capacitor Tantalum
C761	A700233P7	1 nF Capacitor Ceramic
C762	A700233P2	150 pF Capacitor Ceramic
C763	A700233P7	1 nF Capacitor Ceramic
C764	A700235P6	2.7 pF Capacitor Ceramic
C765	A700233P2	150 pF Capacitor Ceramic
C766	A700233P2	150 pF Capacitor Ceramic
C767	A700233P2	150 pF Capacitor Ceramic
C768	A700233P2	150 pF Capacitor Ceramic
C769	A700235P16	18 pF Capacitor Ceramic
C770	A700233P2	150 pF Capacitor Ceramic
C771	A700233P5	470 pF Capacitor Ceramic
C772	A700233P5	470 pF Capacitor Ceramic
C773	A700233P2	150 pF Capacitor Ceramic
C774	A700233P2	150 pF Capacitor Ceramic
C776	A700235P13	10 pF Capacitor Ceramic
C777	A700233P5	470 pF Capacitor Ceramic
C780	A700233P7	1 nF Capacitor Ceramic
C781	J706005P10	220 uF Capacitor Electrolytic
C782	A700233P7	1 nF Capacitor Ceramic
C783	A700235P19	33 pF Capacitor Ceramic
C784	A700233P7	1 nF Capacitor Ceramic
C785	A700233P7	1 nF Capacitor Ceramic
C791	J706261P1	22 nF Capacitor Polyester
C792	A700233P1	100 pF Capacitor Ceramic
C793	A700233P1	100 pF Capacitor Ceramic
D721	A700028P1	114148 Diode Silicon

FREQUENCY SYNTHESIZER FS5111

X402.895/2

NO	CODE	DATA
D722	A700028P1	1114148 Diode Silicon
D723	A706262P1	Variable Cap. Diode
D724	J706262P1	Variable Cap. Diode
D725	A700073P1	BB409 Variable Cap. Diode
D726	A700073P1	BB409 Variable Cap. Diode
D727	A700073P1	BB409 Variable Cap. Diode
D733	J706006P2	BA282 Diode
D734	J706006P2	BA282 Diode
D741	J706026P1	1115401 Diode Silicon
D742	J706026P1	1115401 Diode Silicon
J730	J706215P108	Male Connector
J732	J706215P114	Male Connector
J901	J706214P4	Male Connector
J902	J706214P4	Male Connector
J903	J706214P7	Male Connector
J904	A700072P28	Male Connector
J905	A700072P9	Male Connector
J906	A700072P11	Male Connector
J907	A700102P10	Female Connector
J910	J706223P11	Male Connector
J911	J706223P8	Male Connector
J921	J706219P1	Male Connector
J961	J706219P1	Male Connector
L701	J706029P4	Variable Coil
L702	J708091P1	1.5 uH Coil
L703	A708091P1	1.5 uH Coil
L704	J706083P1	Variable Coil
L705	A700024P19	3.3 uH Coil
L706	A700024P19	3.3 uH Coil
L707	J706083P1	Variable Coil
L708	A700024P15	1.5 uH Coil
L711	J706029P4	Variable Coil
L712	A700024P19	3.3 uH Coil
L713	A700024P19	3.3 uH Coil
L714	J706258P1	Coil
L715	A700024P19	3.3 uH Coil
L716	A700024P19	3.3 uH Coil
L717	J706258P1	Coil
L718	A700024P19	3.3 uH Coil
L721	A700024P23	6.8 uH Coil
L722	A700024P3	0.15 uH Coil
L723	A700024P3	0.15 uH Coil

NO	CODE	DATA
Q702	A700020P1	BC558 Transistor
Q703	A700020P1	BC558 Transistor
Q704	A700020P1	BC558 Transistor
Q711	A707834P1	1N0610L Transistor
Q713	J706283P1	BFR54 Transistor
Q714	J706283P1	BFR54 Transistor
Q715	J706264P1	BF414 Transistor
Q716	J706038P1	2N5245 Transistor
Q717	J706038P1	2N5245 Transistor
Q722	J707515P1	BFX89 Transistor
Q723	J706264P1	BF414 Transistor
Q724	J707515P1	BFX89 Transistor
R704	A700019P34	560 ohm Resistor Depos.
R705	A700019P42	2.7 Kohm Resistor Depos.
R706	A700019P21	47 ohm Resistor Depos.
R707	A700019P49	10 Kohm Resistor Depos.
R708	A700019P49	10 Kohm Resistor Depos.
R709	A700019P42	2.7 Kohm Resistor Depos.
R711	A700019P42	2.7 Kohm Resistor Depos.
R712	A700019P49	10 Kohm Resistor Depos.
R713	A700019P17	22 ohm Resistor Depos.
R714	A700019P17	22 ohm Resistor Depos.
R720	A700019P49	10 Kohm Resistor Depos.
R721	A700019P45	4.7 Kohm Resistor Depos.
R722	A700019P60	82 Kohm Resistor Depos.
R723	A700019P60	82 Kohm Resistor Depos.
R724	A700019P61	100 Kohm Resistor Depos.
R725	A700019P57	47 Kohm Resistor Depos.
R726	A700019P49	10 Kohm Resistor Depos.
R727	A700019P30	270 ohm Resistor Depos.
R728	A700019P48	8.2 Kohm Resistor Depos.
R729	A700019P30	270 ohm Resistor Depos.
R730	A700019P45	4.7 Kohm Resistor Depos.
R731	A700019P30	270 ohm Resistor Depos.
R732	A700019P49	10 Kohm Resistor Depos.
R733	A700019P48	8.2 Kohm Resistor Depos.
R734	A700019P35	680 ohm Resistor Depos.
R735	A700029P57	47 Kohm Resistor Depos.
R736	A700029P31	330 ohm Resistor Depos.
R737	A700019P31	330 ohm Resistor Depos.
R738	A700019P25	100 ohm Resistor Depos.
R739	A700019P39	1.5 Kohm Resistor Depos.

FREQUENCY SYNTHESIZER FS5111

X402.895/2

Nº	CODE	DATA
R741	A700019P43	3.3 Kohm Resistor Depos.
R742	A700019P37	1 Kohm Resistor Depos.
R743	A700019P25	100 ohm Resistor Depos.
R748	A700019P27	150 ohm Resistor Depos.
R749	A700019P25	100 ohm Resistor Depos.
R750	A700019P57	47 Kohm Resistor Depos.
R752	A700016P3	4.7 Kohm Resistor Variable
R753	A700019P37	1 Kohm Resistor Depos.
R754	A700019P25	100 ohm Resistor Depos.
R761	A700019P13	10 ohm Resistor Depos.
R763	A700019P51	15 Kohm Resistor Depos.
R765	A700019P26	120 ohm Resistor Depos.
R769	A700019P36	820 ohm Resistor Depos.
R770	A700019P42	2.7 Kohm Resistor Depos.
R771	A700019P15	15 ohm Resistor Depos.
R772	A700019P57	47 Kohm Resistor Depos.
R773	A700019P55	33 Kohm Resistor Depos.
R774	A700019P50	12 Kohm Resistor Depos.
R775	A700019P33	470 ohm Resistor Depos.
R776	A700010P37	1 Kohm Resistor Depos.
R777	A700019P21	47 ohm Resistor Depos.
R778	A700019P25	100 ohm Resistor Depos.
R779	A700019P34	560 ohm Resistor Depos.
R780	A700019P23	68 ohm Resistor Depos.
R781	A700019P19	33 ohm Resistor Depos.
R782	A700019P44	3.9 Kohm Resistor Depos.
R783	A700019P27	150 ohm Resistor Depos.
R784	A700019P25	100 ohm Resistor Depos.
R785	A700019P39	1.5 Kohm Resistor Depos.
R786	A700019P31	330 ohm Resistor Depos.
R787	A700019P43	3.3 Kohm Resistor Depos.
R788	A700019P26	120 ohm Resistor Depos.
R789	A700019P34	560 ohm Resistor Depos.
R791	A700019P30	270 ohm Resistor Depos.
R792	A700019P38	1.2 Kohm Resistor Depos.
R793	A700019P17	22 ohm Resistor Depos.
R794	A700019P17	22 ohm Resistor Depos.
R798	A700019P37	1 Kohm Resistor Depos.
R799	A700019P54	27 Kohm Resistor Depos.
T701	J70628#G1	Transformer
U701	J706263P1	MC145106
U702	J706238P1	TDA10625 IC

Nº	CODE	DATA
U703	A700029P44	4066B IC
W1	A7000184P1	Jumper
W2	A7000184P1	Jumper

Nº	CODE	DATA
C701	A700233P5	470 pF Capacitor Ceramic
C702	J706005P3	47 uF Capacitor Electrolytic
C703	A700233P5	470 pF Capacitor Ceramic
C704	A700233P5	470 pF Capacitor Ceramic
C705	A700233P7	1 nF Capacitor Ceramic
C706	A701534P7	10 uF Capacitor Tantalum
C707	A700233P5	470 pF Capacitor Ceramic
C708	A700233P5	470 pF Capacitor Ceramic
C710	A701534P1	0.1 uF Capacitor tantal
C711	A700234P9	22 nF Capacitor Pol
C712	A701534P3	0.47 uF Capacitor Tantal
C713	A700233P28	180 pF Capacitor Ceramic
C714	J706256P202	18 pF N1500 Capacitor Ceramic
C715	J706256P205	68 pF N1500 Capacitor Ceramic
C716	A700233P5	470 pF Capacitor Ceramic
C717	A700235P19	33 pF Capacitor Ceramic
C718	A700235P7	3.3 pF Capacitor Ceramic
C719	A700235P16	18 pF Capacitor Ceramic
C720	A700233P7	1 nF Capacitor Ceramic
C721	A700235P7	3.3 pF Capacitor Ceramic
C722	A700235P19	33 pF Capacitor Ceramic
C723	A700235P18	27 pF Capacitor Ceramic
C724	A700233P5	470 pF Capacitor Ceramic
C725	J706256P202	18 pF N1500 Capacitor Ceramic
C726	J706256P205	68 pF N1500 Capacitor Ceramic
C727	A700235P28	180 pF Capacitor Ceramic
C728	A701534P7	10 uF Capacitor Tantalum
C729	A700233P5	470 pF Capacitor Ceramic
C730	A701534P6	4.7 uF Capacitor Tantalum
C731	A700233P2	150 pF Capacitor Ceramic
C732	A700235P7	3.3 pF Capacitor Ceramic
C733	A700013P8	0.39 pF Capacitor Phenolic
C734	A700233P5	470 pF Capacitor Ceramic
C735	A700233P7	1 nF Capacitor Ceramic
C737	J706003P1	1.8-10 pF Capacitor Variable
C738	A700235P13	10 pF Capacitor Ceramic
C739	A701534P4	1 uF Capacitor Tantalum
C740	A700235P23	68 pF Capacitor Ceramic
C741	A701534P7	10 uF Capacitor Tantalum
C742	A700235P7	3.3 pF Capacitor Ceramic
C743	A700233P5	470 pF Capacitor Ceramic
C744	A700233P5	2.2 pF Capacitor Ceramic

Nº	CODE	DATA
C745	J706003P2	2-18 pF Capacitor Variable
C746	A700235P13	10 pF Capacitor Ceramic
C747	A701534P4	1 uF Capacitor Tantalum
C748	A700233P7	1 nF Capacitor Ceramic
C749	A700235P8	3.9 pF Capacitor Ceramic
C750	A700233P1	100 pF Capacitor Ceramic
C751	A701534P5	2.2 uF Capacitor Tantalum
C752	A700233P7	1 nF Capacitor Ceramic
C753	A700233P2	150 pF Capacitor Ceramic
C754	A700235P18	27 pF Capacitor Ceramic
C755	A701534P4	1 uF Capacitor Tantalum
C756	A701534P7	10 uF Capacitor Tantalum
C757	A700233P7	1 nF Capacitor Ceramic
C758	A700233P8	1.5 nF Capacitor Ceramic
C759	A701534P1	0.1 uF Capacitor Tantalum
C760	A701534P3	0.47 uF Capacitor Tantalum
C761	A700233P7	1 nF Capacitor Ceramic
C762	A700233P2	150 pF Capacitor Ceramic
C763	A700233P7	1 nF Capacitor Ceramic
C764	A700235P6	2.7 pF Capacitor Ceramic
C765	A700233P2	150 pF Capacitor Ceramic
C766	A700233P2	150 pF Capacitor Ceramic
C767	A700233P2	150 pF Capacitor Ceramic
C768	A700233P2	150 pF Capacitor Ceramic
C769	A700235P16	18 pF Capacitor Ceramic
C770	A700233P2	150 pF Capacitor Ceramic
C771	A700233P5	470 pF Capacitor Ceramic
C772	A700233P5	470 pF Capacitor Ceramic
C773	A700233P2	150 pF Capacitor Ceramic
C774	A700233P2	150 pF Capacitor Ceramic
C776	A700235P13	10 pF Capacitor Ceramic
C777	A700233P5	470 pF Capacitor Ceramic
C780	A700233P7	1 nF Capacitor Ceramic
C781	J706005P10	220 uF Capacitor Electrolytic
C782	A700233P7	1 nF Capacitor Ceramic
C783	A700235P19	33 pF Capacitor Ceramic
C784	A700233P7	1 nF Capacitor Ceramic
C785	A700233P7	1 nF Capacitor Ceramic
C791	J706261P1	22 nF Capacitor Polyester
C792	A700233P1	100 pF Capacitor Ceramic
C793	A700233P1	100 pF Capacitor Ceramic
D701	A700028P1	1N4148 Diode Silicon

FREQUENCY SYNTHESIZER FS5112

X402.896/2

N _o	CODE	DATA
D702	A700028P1	1N4148 Diode Silicon
D703	A700028P1	1N4148 Diode Silicon
D704	A700028P1	1N4148 Diode Silicon
D705	A700028P1	1N4148 Diode Silicon
D706	A700028P1	1N4148 Diode Silicon
D707	A700028P1	1N4148 Diode Silicon
D708	A700028P1	1N4148 Diode Silicon
D709	A700028P1	1N4148 Diode Silicon
D710	A700028P1	1N4148 Diode Silicon
D711	A700028P1	1N4148 Diode Silicon
D712	A700028P1	1N4148 Diode Silicon
D713	A700028P1	1N4148 Diode Silicon
D714	A700028P1	1N4148 Diode Silicon
D721	A700028P1	1N4148 Diode Silicon
D722	A700028P1	1N4148 Diode Silicon
D723	A706262P1	Variable Cap. Diode
D724	A706262P1	Variable Cap. Diode
D725	A700073P1	BB409 Variable Cap. Diode
D726	A700073P1	BB409 Variable Cap. Diode
D727	A700073P1	BB409 Variable Cap. Diode
D733	J706006P2	BA282 Diode
D734	J706006P2	BA282 Diode
D741	J706026P1	1N5401 Diode Silicon
D742	J706026P1	1N5401 Diode Silicon
J730	J706215P108	Male Connector
J732	J706215P114	Male Connector
J901	J706214P4	Male Connector
J902	J706214P4	Male Connector
J903	J706214P7	Male Connector
J904	A700072P28	Male Connector
J905	A700072P9	Male Connector
J906	A700072P11	Male Connector
J907	A700102P10	Female Connector
J910	J706223P11	Male Connector
J911	J706223P8	Male Connector
J921	J706219P1	Variable Coil
J961	J706219P1	1.5 uH Coil
L701	J706029P4	Variable Coil
L702	J708091P1	1.5 uH Coil
L703	A708091P1	Variable Coil
L704	J706083P1	3.3 uH Coil
L705	A700024P19	

N _o	CODE	DATA
L706	A700024P19	3.3 uH Coil
L707	J706083P1	Variable Coil
L708	A700024P15	1.5 uH Coil
L711	J706029P4	Variable Coil
L712	A700024P19	3.3 uH Coil
L713	A700024P19	3.3 uH Coil
L714	J706258P1	Coil
L715	A700024P19	3.3 uH Coil
L716	A700024P19	3.3 uH Coil
L717	J706258P1	Coil
L718	A700024P19	3.3 uH Coil
L721	A700024P23	6.8 uH Coil
L722	A700024P3	0.15 uH Coil
L723	A700024P3	0.15 uH Coil
Q701	A700017P1	BC548 Transistor
Q702	A700020P1	BC558 Transistor
Q703	A700020P1	BC558 Transistor
Q704	A700020P1	BC558 Transistor
Q711	A707834P1	VI0610L Transistor
Q713	J706283P1	BFR54 Transistor
Q714	J706283P1	BFR54 Transistor
Q715	J706264P1	BF414 Transistor
Q716	J706038P1	2N5245 Transistor
Q717	J706038P1	2N5245 Transistor
Q722	J707515P1	BFX89 Transistor
Q723	J706264P1	BF414 Transistor
Q724	J707515P1	BFX89 Transistor
R701	A700019P21	47 ohm Resistor Depos.
R702	A700019P39	1.5 Kohm Resistor Depos.
R703	A700019P53	22 Kohm Resistor Depos.
R704	A700019P34	560 ohm Resistor Depos.
R705	A700019P42	2.7 Kohm Resistor Depos.
R706	A700019P21	47 ohm Resistor Depos.
R707	A700019P49	10 Kohm Resistor Depos.
R708	A700019P49	10 Kohm Resistor Depos.
R709	A700019P42	2.7 Kohm Resistor Depos.
R711	A700019P42	2.7 Kohm Resistor Depos.
R712	A700019P47	10 Kohm Resistor Depos.
R713	A700019P17	22 ohm Resistor Depos.
R714	A700019P17	22 ohm Resistor Depos.
R720	A700019P49	10 Kohm Resistor Depos.
R721	A700019P45	4.7 Kohm Resistor Depos.

FREQUENCY SYNTHESIZER FS5112

X402..896/2

Nº	CODE	DATA
R722	A700019P60	82 Kohm Resistor Depos.
R723	A700019P60	82 Kohm Resistor Depos.
R724	A700019P61	100 Kohm Resistor Depos.
R725	A700019P57	47 Kohm Resistor Depos.
R726	A700019P49	10 Kohm Resistor Depos.
R727	A700019P30	270 ohm Resistor Depos.
R728	A700019P48	8.2 Kohm Resistor Depos.
R729	A700019P30	270 ohm Resistor Depos.
R730	A700019P45	4.7 Kohm Resistor Depos.
R731	A700019P30	270 ohm Resistor Depos.
R732	A700019P48	10 Kohm Resistor Depos.
R733	A700019P35	8.2 Kohm Resistor Depos.
R734	A700029P57	680 ohm Resistor Depos.
R735	A700029P57	47 Kohm Resistor Depos.
R736	A700029P31	330 ohm Resistor Depos.
R737	A700019P31	330 ohm Resistor Depos.
R738	A700019P25	100 ohm Resistor Depos.
R739	A700019P39	1.5 Kohm Resistor Depos.
R741	A700019P43	3.3 Kohm Resistor Depos.
R742	A700019P37	1 Kohm Resistor Depos.
R743	A700019P25	100 ohm Resistor Depos.
R748	A700019P27	150 ohm Resistor Depos.
R749	A700019P25	100 ohm Resistor Depos.
R750	A700019P57	47 Kohm Resistor Depos.
R752	A700016P3	4.7 Kohm Resistor Variable
R753	A700019P37	1 Kohm Resistor Depos.
R754	A700019P25	100 ohm Resistor Depos.
R761	A700019P13	10 ohm Resistor Depos.
R763	A700019P51	15 Kohm Resistor Depos.
R765	A700019P26	120 ohm Resistor Depos.
R769	A700019P36	820 ohm Resistor Depos.
R770	A700019P42	2.7 Kohm Resistor Depos.
R771	A700019P15	15 ohm Resistor Depos.
R772	A700019P57	47 Kohm Resistor Depos.
R773	A700019P55	33 Kohm Resistor Depos.
R774	A700019P50	12 Kohm Resistor Depos.
R775	A700019P33	470 ohm Resistor Depos.
R776	A700010P37	1 Kohm Resistor Depos.
R777	A700019P21	47 ohm Resistor Depos.
R778	A700019P25	100 ohm Resistor Depos.
R779	A700019P34	560 ohm Resistor Depos.
R780	A700019P23	68 ohm Resistor Depos.

Nº	CODE	DATA
R781	A700019P19	33 ohm Resistor Depos.
R782	A700019P44	3.9 Kohm Resistor Depos.
R783	A700019P27	150 ohm Resistor Depos.
R784	A700019P25	100 ohm Resistor Depos.
R785	A700019P39	1.5 Kohm Resistor Depos.
R786	A700019P31	330 ohm Resistor Depos.
R787	A700019P43	3.3 Kohm Resistor Depos.
R788	A700019P26	120 ohm Resistor Depos.
R789	A700019P34	560 ohm Resistor Depos.
R791	A700019P30	270 ohm Resistor Depos.
R792	A700019P38	1.2 Kohm Resistor Depos.
R793	A700019P17	22 ohm Resistor Depos.
R794	A700019P37	22 ohm Resistor Depos.
R798	A700019P37	1 Kohm Resistor Depos.
R799	A700019P54	27 Kohm Resistor Depos.
S901	J706322G1	Channel Switch
T701	J706284G1	Transformer
U701	J706263P1	MC145106
U702	J706238P1	TDA1062S IC
U703	A700029P44	4066B IC
V901	K805090G1	LMP
W1	A700184P1	Jumper
W2	A700184P1	Jumper

TECHNICAL SPECIFICATION

CQM5330 S12

Guaranteed performance specifications unless otherwise noted.

Typical values are given in brackets.

GENERAL

Frequency Range

66 - 88 MHz

Channel Separation

CQM5332: 30/25 kHz

CQM5333: 20 kHz

CQM5334: 12.5 kHz

Maximum Frequency Deviation

CQM5332: ± 5 kHz

CQM5333: ± 4 kHz

CQM5334: ± 2.5 kHz

Modulation Frequency Range

CQM5332: 300 - 3000 Hz

CQM5333: 300 - 3000 Hz

CQM5334: 300 - 2550 Hz

Maximum RF Bandwidth

RX: 1.5 MHz

TX: 2.5 MHz

Antenna Impedance

50 ohm

Maximum number of channels

12

Supply Voltage

Minimum: 10.8 V

Nominal: 13.2 V

Maximum: 16.6 V

Temperature Range

-30°C to $+60^{\circ}\text{C}$

Dimensions

B x D x H: 180 x 190 x 60 mm

Weight

1.8 kg.

RECEIVER

Sensitivity

12 dB SINAD (EIA), $\frac{1}{2}$ e.m.f.:

0.3 μV (0.25 μV)

EIA measuring conditions:

$\Delta f = \pm 2/3 \Delta f_{\text{max}}$; $f_{\text{mod}} = 1$ kHz

20 dB SINAD (CEPT), e.m.f.:

CQM5332: 0.75 μV (0.55 μV)

CQM5333: 0.75 μV (0.55 μV)

CQM5334: 1.0 μV (0.75 μV)

CEPT measuring conditions:

$\Delta f = 60\% \Delta f_{\text{max}}$; $f_{\text{mod}} = 1$ kHz

Measured with psophometric filter

Crystal Frequency Range

36 - 48 MHz

Receiver VCO Frequency Range

77 - 99 MHz

Frequency Stability

Conforms with governments regulations

Modulation Acceptance Bandwidth

CQM5332: ± 7 kHz (± 7.5 kHz)

Adjacent Channel Selectivity

EIA

CQM5332: 75 dB (85 dB)

FTZ

CQM5333: 70 dB (85 dB)

CEPT

CQM5332: 75 dB (85 dB)

CQM5334: 65 dB (85 dB)

Spurious Rejection EIA

80 dB (85 dB)

Intermodulation Attenuation

EIA

CQM5332: 70 dB (72 dB)

FTZ

CQM5333: 70 dB (72 dB)

CEPT

CQM5332: 70 dB (75 dB)

CQM5333: 70 dB (75 dB)

CQM5334: 70 dB (73 dB)

Blocking

90 dB/uV (104 dB/uV)

Radiation

Conducted: max. 0.8 nW

Radiated: max. 0.8 nW

AF Load Impedance (Loudspeaker)

4 ohm

AF Power Output

3 W

AF Distortion

5% (1.5%)

60% Δf max., 1 kHz, 1 W, RF 1 mV

Audio Frequency Response CEPT/FTZ

fm: 300 - 3000 Hz

+1/-3 dB (+0/-1.5 dB)

fm: 400 - 2700 Hz

+1/-1.5 dB (+0/-1 dB)

fm: 300 - 2550 Hz

+1/-3 dB (+0/-1 dB)

Relative to 1000 Hz, -6 dB/octave

Hum and Noise

Squelched: 80 dB (better than 85 dB)

Unsquelled: 55 dB (57 dB)

Squelch Attack Time (EIA)

150 ms (110 ms)

Squelch Recovery Time

250 ms (200 ms)

Squelch Closing Time (EIA)

150 ms (50 ms)

Current Consumption

Squelched: 350 mA (330 mA)

Receive, AF 2 W: 750 mA (730 mA)

(1 channel without tone equipment, 13.2 V supply)

TRANSMITTER

RF Power Output

CQM5332-6: 6 W

CQM5332-25: 25 W

CQM5333-6: 6 W

CQM5333-25: 25 W

CQM5334-6: 6 W

CQM5334-25: 25 W

($R_L = 50$ ohm)

Crystal Frequency Range

15 - 21 MHz

Crystal Frequency Multiplication

x 4

Transmitter VCO Frequency Range

66 - 88 MHz

Frequency Stability

Conforms with government regulation

300 - 2550 Hz

+1/-3 dB (+0.5/-2 dB)

Relative to 1000 Hz, 6 dB/octave

Undesired Radiation

max. 0.2 μ W

Modulation Distortion (CEPT)

max. 3%

$f_{\text{mod}} = 1000 \text{ Hz}$, $\Delta f = 60\% \Delta f \text{ max.}$

max. 5%

$f_{\text{mod}} = 300 \text{ Hz}$, $\Delta f = 5.5\% \Delta f \text{ max.}$

measured with 750 μ sec. de-emphasis

Sideband Noise Power, CEPT

less than 70 dB

Modulation AF Input Impedance

560 ohm

FM Hum and Noise, CEPT

55 dB (57 dB)

measured with 750 μ sec. de-emphasis

Modulation Sensitivity

70 mV \pm 2 dB

(60% $\Delta f \text{ max.}$, 1 kHz)

Attack Time

50 ms

Modulation Response

300 - 3000 Hz

+1/-3 dB (+0.5/-2 dB)

relative to 1000 Hz, 6 dB/octave

Current Consumption

6 W: less than 3 A (2.5 A)

25 W: less than 5.9 A (5.0 A)

400 - 2700 Hz

+1/-1.5 dB (+0.5/-1 dB)

relative to 1000 Hz, 6 dB/octave

GENERAL DESCRIPTION

CQM5330 S12

The Stornophone 5000 is a mobile radiotelephone unit with self-contained controls and loudspeaker.

A comparison of the various models is presented in the table below.

Although compact in size, it contains a transmitter/receiver, optional 5-tone sequential encoder/decoder, or Channel Guard (Pilot tone), Group Call, All Call, and up to 12 transmit and receive channels.

Type	CQM5332		CQM5333		CQM5334	
SPEC	6	25	6	25	6/10	25
Frequency Range MHz	66 - 88		66 - 88		66 - 88	
RF Power W	6		25		6/10	25
Channel Spacing kHz	30/25		20		12.5	
Max. Number of Channels	12		12		12	

ACCESSORIES

Standard accessories include:

Mounting frame	HS5001	Retainer for MC5001
Power cable	HS5002	Retainer, with switches, for MC5001
Fist microphone with retainer or Fixed - mount microphone	MC5002	Cylindrical handmicrophone with build-in amplifier and press-to talk switch. Fitted with a coiled cord terminated into a connector which fits into the microphone retainer.
External loudspeaker		
External switches		
LS701 Loudspeaker enclosed in a plastic housing, complete with cable.	HS5003	Retainer for MC5002, without hook switch.
MC702b Dynamic fist microphone with adjustable output level.	HS5004	Retainer for MC5002, with hook switch.
JB701a Junction box for MC702b. Consists of a plastic housing provided with cable for soldering assembly. Junction box is to mounted behind the first microphone retainer.	MK5001	Installation kit containing connectors, power cable, fuses and fuseholders.
MC703a Desk microphone with PTT (Push -to - Talk) switch for fixed installations.	MN703	Desk stand for fixed installations.
MC704 Microphone with chockabsorbing mounting bracket for mobile installation.	MN704	Mounting bracket for the radio cabinet.
MK704 Mounting kit consisting of 2 flexible tubes, used for mounting the MC704 in close-talk position.	MN5001	Mounting frame for mobile installations allowing the radio to be fixed in 36 positions. Includes a base plate with locking screw.
MC5001 Fist microphone with retractable spiral cable for mobile installation.	MN5002	Mounting cassette for the radio cabinet (see mechanical layout).
	MT5001	Microphone with retainer. The retainer contains a microswitch which is used to switch off the internal loudspeaker, when the microphone is lifted.

- SU701 Transmitter keying switch for mounting on the steering column.
- SU702 Transmitter keying switch for mounting on the dashboard.
- SU704 Switch circuit for autoradio mounting.
- SU5003 External alarm with timer (Horn Alarm).

Power Supply Units:

Equipment

	220 V AC	+24 V DC
CQM5000, max. 6/10 W	PS703	PS704
CQM5000, max. 25 W	PS5001	PS702

MECHANICAL AND ELECTRICAL DESCRIPTION

The internal construction of CQM5000 is on an H-frame chassis with a shelf separating the receiver/transmitter (RF) printed circuit board and the various option printed boards. Front panel controls are an integral part of the printed board assemblies.

The chassis is a die cast aluminium frame comprising the left and right sides, the back, and a shelf located midway between the top and bottom. The chassis front is open and looks like an "H" viewed from the front.

Interconnection to the package exterior and to internal options are made via the Frequency Synthesizer Board located on the option side of the H-frame. A test connector is also located on the synthesizer board and is accessible from the rear of the radio.

The moulded plastic front is directly attached to the chassis and has the speaker mounted to it. A separate moulded speaker grill and aluminum nameplate are attached to the front.

The top and bottom covers slides under the edge of the front and are then secured by screws at the rear.

The tone signalling encoder/decoder board (TQ), the Frequency Synthesizer Board (FB) and the Frequency Control (FC) mount in the top section of the chassis.

Their switches and push buttons mount directly to the boards and protrude through the front.

Thin cast shields with adjustment holes are placed over the transmitter and receiver oscillators and parts of the transmitter in order to reduce spurious radiation.

CIRCUIT DESCRIPTION

RECEIVER

The receiver circuitry is placed on the main board and can be divided into:

- Receiver front end
- 1st IF section with first and second oscillator
- 455 kHz 2nd IF section with demodulator.

FRONT-END

The receiver front-end consists of a dual-resonator input filter, a transistor RF amplifier, Q401, a triple-resonator intermediate filter and a FET mixer, Q402. The drain of the FET is terminated in the first IF resonant circuit which adapts the output impedance to

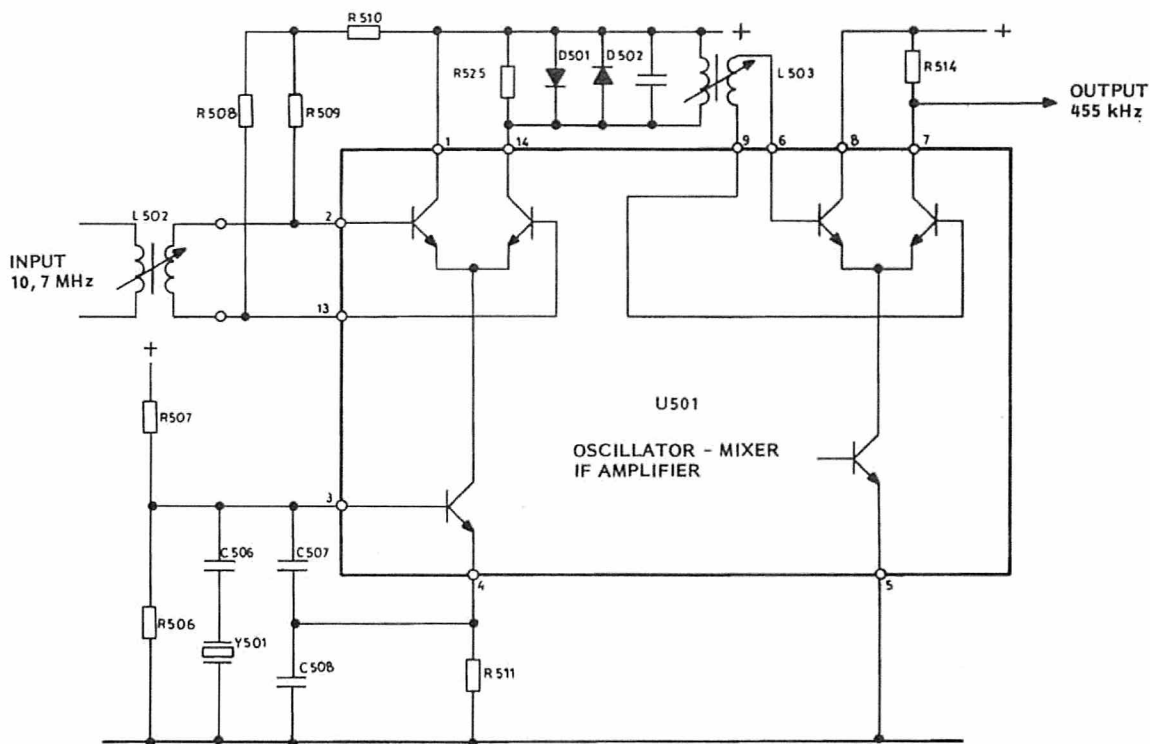

FIG. 1. SECOND OSCILLATOR , IF MIXER , AND IF AMPLIFIER

the crystal filter. The front-end, antenna relay, first mixer and part of the transmitter PA interconnections are designed in micro-stripline techniques on the mainboard.

1st IF

The first IF frequency is 10.7 MHz. The output from the crystal filter is fed to a dual-gate MOSFET amplifier, Q501, the output sig-

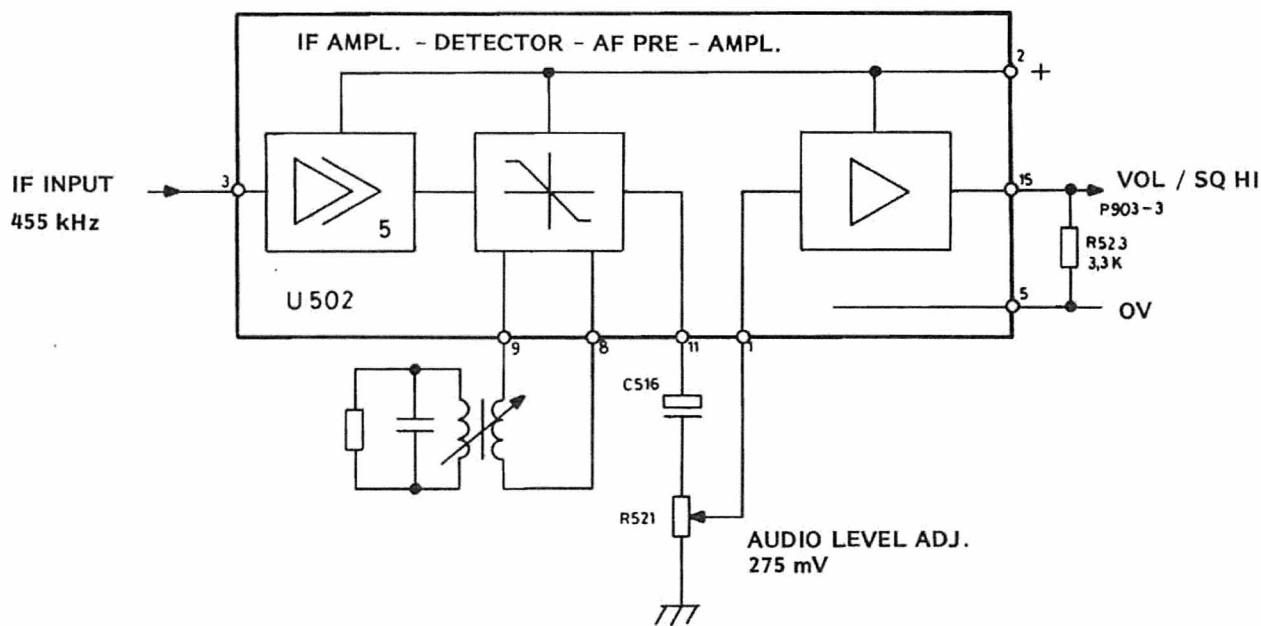

FIG. 2. IF AMPLIFIER , DETECTOR , AND AF PREAMPLIFIER

nal of which is fed to the second mixer, U501, a single balanced, self-oscillating, active mixer. Out of the second mixer comes the 455 kHz IF signal. Two diodes, D501-502, limit the output from the mixer.

455 Hz IF/DEMODULATOR

The selectivity of the 455 kHz IF amplifier is formed by a ceramic filter fed from a 455 kHz amplifier/impedance transforming stage. The final 455 kHz amplification and limiting is performed by an integrated circuit, U502, which also contains the quadrature FM detector and the AF amplifier/output emitter follower for the audio line signal.

SQUELCH AND AUDIO CIRCUITS

The audio line signal (Vol/Sq - HI) is fed to a selective amplifier stage, where noise (frequencies around 7 kHz) is extracted from the audio signal. Via the squelch potentiometer R607, this signal reaches an expander stage which improves the level discrimination characteristics of the circuit. A passive voltage doubler circuit (D603-D604) with high source impedance performs the action of an average value rectifier. A Schmitt Trigger gives the necessary hysteresis and a well-defined output from the following buffer stage, Q605. In the squelched condition and during transmissions this output is +1.5 V and mutes the audio power amplifier. The transmit indicator is part of the muting function.

A push button switch, S601, cancels the squelch function, when depressed, by grounding the base of Q601.

AUDIO

In sets with Pilot tone option, the audio line signal is fed to the Pilot tone board for filtering and back to the main board. In sets without Pilot tone this path is bypassed and the audio line signal is fed directly to the passive deemphasis network R629-C608 followed by the volume control. The volume control potentiometer R630 is mounted directly on the RF board and protrude through the front panel. The audio output amplifier U601 is a monolithic IC package capable of driving the loudspeaker at the desired power level. The output amplifier can be muted with a DC signal from the audio mute gate, which combines different logic signals to decide whether the amplifier should be active or not.

These inputs are:

- Regulated TX Voltage
- Squelch cancel
- Squelch signal

In sets equipped with Pilot tone and/or 5-tone sequential option, an RX mute function is routed from the option board to make the extra mute conditions possible. The value of C610 in the feed back loop is chosen as the best compromise between battery ripple rejection and receiver squelch attack time. The pilot lamp in the channel knob is supplied from A+, but controlled by the regulated 8.5 V via transistor Q968.

TRANSMITTER

The transmitter consists of a modulation processor, an exciter, and a power amplifier, all assembled on the main board along with the receiver.

The exciter contains an audio processor, all frequency multiplier functions, and includes those stages operating at low enough power levels to avoid heat sinks. The exciter out-

put is at the carrier frequency when applied to the power amplifier. The power amplifier boosts the signal to the proper level, and includes a low pass filter for suppressing harmonics and a circuitry which permits adjustment of the operating power level. The PA low pass filter connects to the antenna relay via a stripline on the board.

MODULATION PROCESSOR

The signal from the microphone load, R901 on the FS board, is applied to amplifier U101b.

The transmitter audio frequency response is shaped by the feedback network R104-R103-C104.

The modulation limiting is obtained in the feedback network formed by D101, D102, R105, R106 and R107. The maximum permissible frequency deviation is set by a DEV. MAX. potentiometer on the RF Board.

Amplifier U101A is operated as an active low-pass splatter filter feeding the modulating input of the FM oscillator.

EXCITER

The exciter takes the synthesized signal, filters it to reduce spurious signals and amplifies it. Three amplifier stages (Q201-2-3) and four filters (L201-2-4-5) are used in a narrow band design which limits the maximum frequency spread of the transmitter.

The exciter has two test points (TP201-2) for measurements and alignment.

POWER AMPLIFIER

The PA is constructed on the main board and employs two broadband untuned amplifier stages Q205, Q206. Two amplifier configurations are available providing options of power le-

vels of 6 (10) watts or 25 watts. A power control circuit is included to sense the output RF level and keep it constant with variations in temperature and supply voltage. This circuit also limits the peak power to less than maximum, as specified by the authorities, while still maintaining the output as near maximum as possible. The output power level can be set with a potentiometer, R221, over at least a 3:1 range. The transmitter delivers rated power into a 50-ohm load. A load SWR of 1.4:1 will result in more than 90% of the power being radiated. The transmitter will operate into a load with up to 3:1 SWR.

The power adjustment is achieved by controlling the supply voltage of power amplifier Q205 via transistor Q207. This series transistor is biased by a voltage generated by the feedback network C240, D201, Q201, Q209, and Q208.

FREQUENCY SYNTHESIZER

The frequency synthesizer provides up to 12 Channels and is built on a printed wiring board which mounts in the top section of the radio set. There are two versions of the board, a single channel board, FS5331, and a multi-channel board, FS5332.

The frequency of the single channel board is set by putting a binary code directly on the programmable divider input while the multi-channel board uses a channel selector and a Frequency Control unit, FC5001. The channel selector is mounted directly on the synthesizer board and protrudes through the front panel.

The Frequency Control unit FC5001 fits into a shield which is placed over the main section of the synthesizer board.

The Frequency Synthesizer board also carries all interconnections between the tone modules and the RF module, and it has two connectors at the rear for accessories and the power supply cable.

SUPPLY VOLTAGE DISTRIBUTION SYSTEM

The battery voltage (A + BATT) enters the radio via two pins of the rear system connector to the synthesizer board. Both inputs are connected to reverse polarity protection diodes D741, D742. The ground lead comes through the same connector and is connected to chassis ground through a fusible printed wiring path which will open in case of the ground wire being accidentally connected to A+.

One battery input goes directly from the synthesizer board via a feed-through capacitor and a connector P907 to the transmitter PA stages. The other input feeds through J903 to the main board for two functions. One branch for the audio amplifier passes through an RC-ripple filter R638 - C618 and one of the ON/OFF switch sections U602. The other section of the ON/OFF switch controls the V_B + to the voltage regulator U602 consisting of a monolithic regulator. The regulator output is fixed at 8.5 V by means of a factory adjusted resistor.

Regulated 8.5 V is switched to either the receiver or the transmitter by the antenna relay. The antenna relay is also supplied by the 8.5 V regulated.

The squelch circuit, the modulation processor, the Frequency Synthesizer and parts of the IF amplifier, U502, are supplied directly from the continuous 8.5 V.

The receiver front-end, the 10.7 MHz IF stages and the second oscillator are supplied from 8.5 V RX. The transmitter exciter is supplied from 8.5 V TX.

In sets with 5-tone sequential option or Pilot tone, the PTT (Push to talk) lead runs through the option board to provide for correct tone keying function.

WARNING

The transmitter PA transistors contain Beryllia which is poisonous when absorbed by the human body. Dissection, filing, or grinding of these transistor may be hazardous.

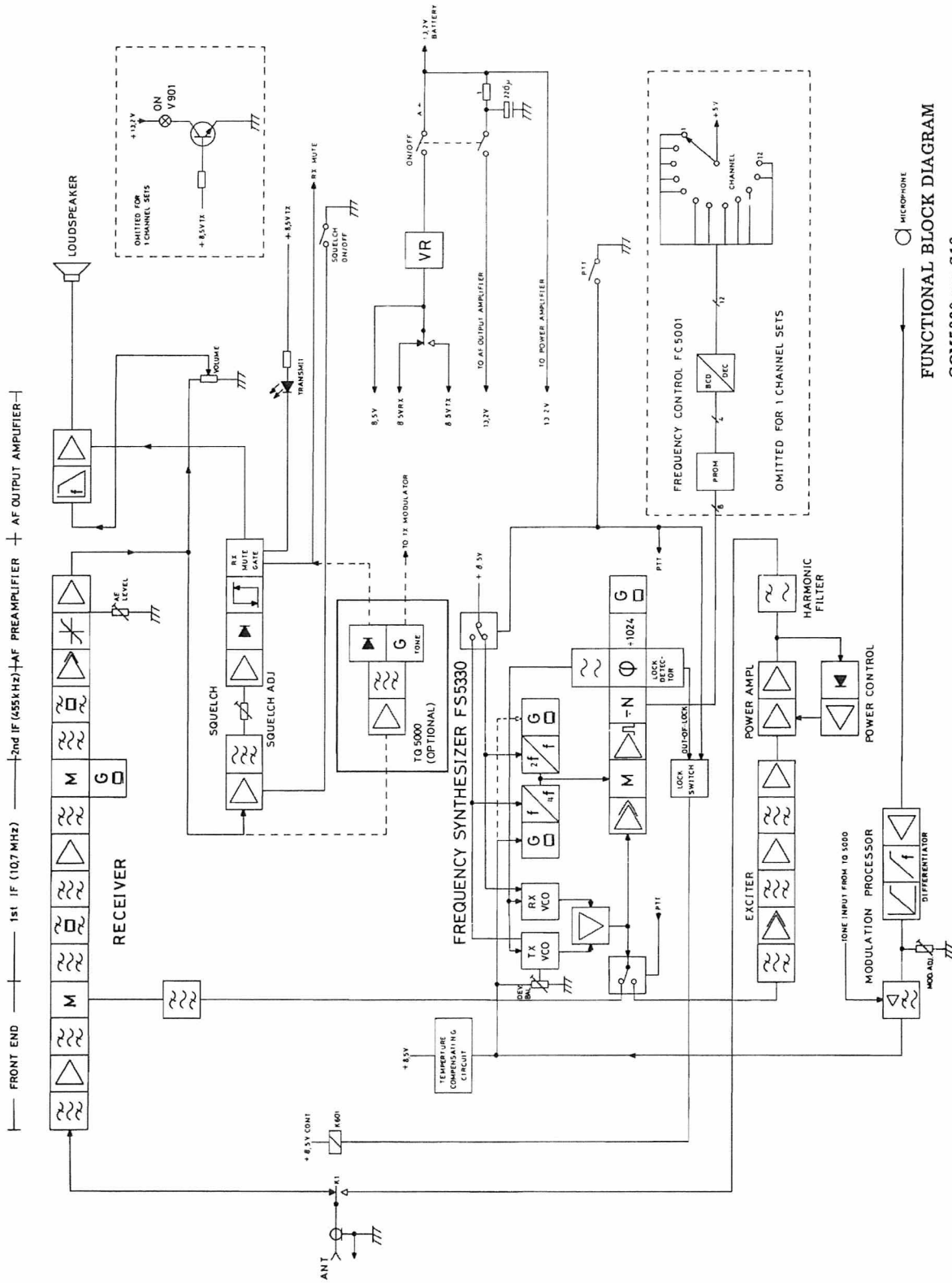

ADJUSTMENT PROCEDURE

CQM5330 S12

This adjustment procedure applies to the following radiotelephone types:

- CQM5332 S12 30/25 kHz Channel spacing
- CQM5333 S12 20 kHz Channel spacing
- CQM5334 S12 12.5 kHz Channel spacing

Before making adjustments to the radiotelephone transmitter/receiver, read the type label and note the channel frequencies.

Check all straps according to the notes on the diagrams. Also check the selective calling tone equipment, if any, against the coding instructions; refer to description of tone equipment.

All screens must be in place and properly secured during the adjustments.

- Frequency counter with attenuator $Z_{in} = 50 \text{ ohm}$; sensitivity 100 mV at 88 MHz
- RF diode probe Storno 95.0089-00
- RF coaxial probe Storno 95.0179-00
- DC power supply 10.8 V - 16.6 V; 6A
- Oscilloscope 0 - 5 MHz min.

MISCELLANEOUS

- 4 ohm/3 W resistor 3 x Storno code 82.5026-00
- 22 μ F/40 V electrolytic capacitor Storno code 73.5107-00
- Connector, 11-pin house Storno code 41.5543-00
- Connector, 8-pin house Storno code 41.5542-00
- Pins for connectors Storno code 41.5551-00
- Trimming tools

MEASURING INSTRUMENTS

The following list contains instruments necessary for adjusting the radiotelephone and checking its performance characteristics:

- DC Voltmeter $R_{in} \geq 1 \text{ Mohm}$
- AC Voltmeter $Z_{in} > 1 \text{ Mohm}/50 \text{ pF}$
- Multimeter $R_i \geq 20 \text{ Kohm/Volt}$
- Distortion meter e.g. Storno E11c
- RF Watt meter 25 W/50 ohm/66-88 MHz
- Deviation meter 66-88 MHz
- RF generator $Z_{out} = 50 \text{ ohm}$; 66-88 MHz
- 10.7 MHz signal generator e.g. Storno TS-G21B

The following tables show the frequency ranges of the CQM5330 S12 radiotelephone signals:

SIGNAL	FREQUENCY MHz
TX VCO	66 - 88
TX crystal	15 - 21
TX crystal multiplication	x4
RX VCO	77 - 99
RX crystal	36 - 48
RX crystal multiplication	x2

Table 1.

Channel spacing kHz	Reference Crystal MHz	Min. Divider input frequency MHz	Max. Divider input frequency MHz	Reference frequency kHz
20	10.240	2.560	5.110	10
12.5 or 25 ¹⁾	12.800	3.200	6.3875	12.5
15.0 or 30 ¹⁾	15.360	3.840	7.665	15

Table 2 ¹⁾ Two steps per channel

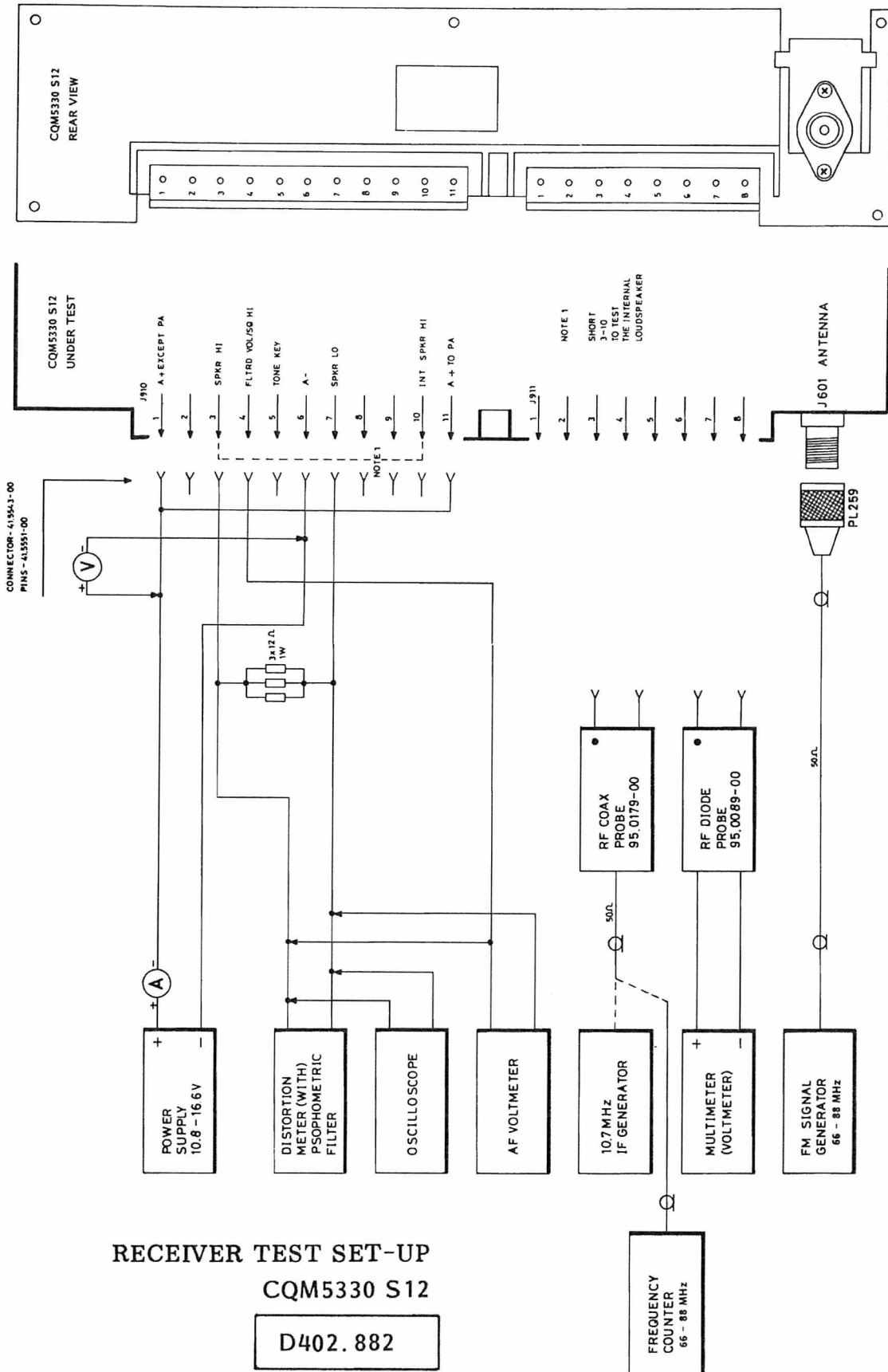

RECEIVER ADJUSTMENT

CHECKING 8.5 V REGULATED SUPPLY

Turn the power supply ON and set the voltage to 13.2 V. Set the power supply current limiter to 1 A.

Turn the radiotelephone ON by depressing the ON/OFF button. Note the light in the Channel selector, if any, is on.

Depress the Squelch button.

Set the volume control to minimum.

Connect the DC voltmeter to J901 pin 3 and read the Voltage.

Requirement: 8.5 V \pm 0.15 V

If the requirement is not fulfilled check resistor R636 against the colour code of U602.

U602 colour code	R636 Value
Brown	omit
Red	270
Orange	100
Yellow	47
Green	22
Blue	6.8

Adjust the power supply voltage to 16.6 V and read the 8.5 V regulated. Compare the change in the 8.5 Volt regulated to the value obtained at 13.2 V.

Requirement: \leq 50 mV

Repeat the procedure with the power supply adjusted for 10.8 V

FREQUENCY SYNTHESIZER ALIGNMENT

Check the PROM U801, the TX mixer crystal, the RX mixer crystal, and the reference crystal and verify the frequencies and prom codes.

Mixer crystal output

Connect RF diode probe 95.0089-00 with multimeter to test point TP701. (1 V range).

Adjust L711 for maximum deflection on the multimeter.

Adjust L707 for maximum deflection on the multimeter.

Requirement: 250 mV \pm 125 mV
(corresponding to -10 dBm to -4 dBm).

Note: Be careful not to resonate L707 to the false harmonics. If in doubt consult table 1 or check the crystal oscillator output with a spectrum analyzer.

Receiver VCO

Connect the oscilloscope to test point TP706.

The oscilloscope measures the synthesizer's lock signal which is +8 volts with very narrow negative going pulses when in locked position. Unlocked condition is indicated by a variable duty signal or logic "low".

Typical trace for locked condition

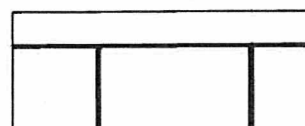

The pulse repetition rate is 10 or 12.5 kHz corresponding to the channel spacing respectively. Select the channel whose frequency is closest to the center frequency.

Adjust C745 for as narrow pulses as possible. Connect the multimeter to test point TP703. Adjust C745 for 4.0 volt on the multimeter.

If the radio has more than one channel adjust C745 so that the multimeter reading for all channels are evenly distributed around 4.0 volt. The high channel frequency shall give a voltage reading above 4.0 volt equal to the low channel reading below 4.0 volt.

Example:

High channel reading: 4.8 volt (4.0 + 0.8)

Center channel reading: 4.0 volts

Low channel reading: 3.2 volt (4.0 - 0.8)

The deviation of the voltage reading from 4.0 volts depends on the spread of the high and low channel.

Mixer Crystal Frequency

Connect coax probe 95.0179-00 to test point TP701.

Connect the frequency counter to the probe and read the frequency.

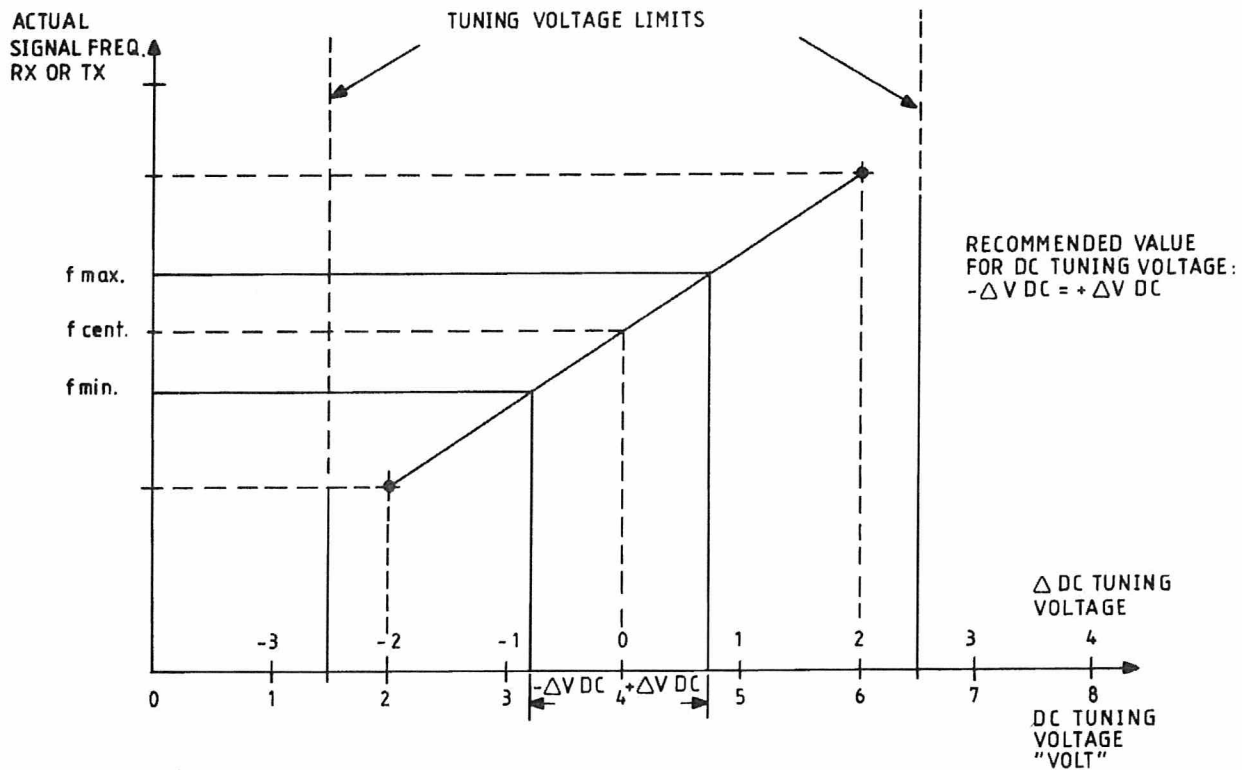

$$f = f_x \times 2 \quad (f_x = \text{crystal frequency})$$

Adjust L711 to the calculated frequency.

Requirement: $f \pm 0.3 \text{ ppm at } 25^\circ\text{C}$.

ppm = parts per million = 10^{-6}

Injection Frequency

Connect coax probe 95.0179-00 to test point TP401.

Connect the frequency counter to the probe.

Calculate the injection frequency for all channels.

$$f_{inj} = f_{ant} + 10.7 \text{ (MHz)}$$

Select, one by one, the channels and read the injection frequency.

Requirement: $F_{inj} \pm 0.4 \text{ ppm}$

IF AMPLIFIERS

Connect a 10.7 MHz signal generator to TP401 via coax probe 95.0179-00.

Connect RF diode probe 95.0089-00 with multimeter to test point TP501. (50 μA range).

During adjustment the RF generator output must be kept low enough to prevent limiting in the IF stages, i. e. a maximum reading of 50 μA on the multimeter.

Adjust coils L503, L502, L501, and L406, in that order, for maximum deflection on the multimeter.

FRONT-END

Connect the RF probe 95.0089-00 and the multimeter to test point TP501. (50 μA range).

Connect an unmodulated RF generator to the antenna connector, J601.

Set the generator frequency to the receiver frequency.

Adjust the generator output to produce a deflection on the multimeter, i. e. a maximum reading of 50 μA on the multimeter.

Adjust L401 and L402 for maximum deflection.

Detune L403 and 405 as much as possible.

Adjust L404 for maximum deflection on the multimeter. This is the only adjustment of L404 and it must not be touched during the rest of the procedure.

Adjust L403 and L405 for maximum deflection on the multimeter.

Readjust L401 and L402 for maximum deflection.

Remove the RF diode probe.

Standard Test condition:

Connect the RF generator to antenna connector and adjust the output to 1 mV e.m.f.

Modulate the RF generator with 1000 Hz to 60% of Δf max.

CQM5332 S12 ± 3 kHz

CQM5333 S12 ± 2.4 kHz

CQM5334 S12 ± 1.5 kHz

Connect a 4 ohm/3 W resistor load to connector J910/37 (SPKR HI-SPKR LO).

Connect an AF voltmeter to J910/4-7 (FLTD VOL SPKR LO).

IF DEMODULATOR

Turn R521 halfway up.

Adjust L504 for maximum reading on the AF voltmeter.

Connect a distortion meter and AF voltmeter across the 4 ohm resistor. (if Storno E11c distortion meter is used switch the function to AF voltmeter).

Adjust the volume control for approx. 2 V across the load.

Adjust L501 and L406 for minimum distortion. The demodulated signal may be monitored on an oscilloscope connected in parallel with the distortion meter.

Connect the AF voltmeter and distortion meter to J910/4-7 (FLTD VOL - SPKR LO).

Adjust R521 for a reading of 275 mV on the AF voltmeter.

Requirement: 275 mV ± 5 mV.

Read the distortion.

Typical Total Harmonic Distortion (THD) will be less than 5%.

RECEIVER SENSITIVITY

EIA or CEPT method may be used.

Method of measurement CEPT

The purpose of the measurement is to define the ratio of one condition to another.

The first condition is the one where a modulated RF-signal drives the receiver into full limiting. The audio output is measured with the distortion meter (in the CAL position) and, disregarding the amplitude of the audio, this is adjusted to read 100% on the meter scale; this is our reference condition consisting of signal +noise +distortion, where 'signal' is the modulation of the RF, 'noise' is the lowest possible amount achieved from that particular receiver, when receiving a strong carrier, and 'distortion' is the modulation being slightly distorted in passing through the receiver.

The second condition is the one where the signal (modulation) is removed with a notch filter and the RF-signal is lowered in amplitude until the remaining noise and distortion increases to 20 dB below the first condition, as read on the distortion meter scale. This corresponds to a reading of 10%, 10 being 20 dB below 100, which was our reference condition.

In practice our first condition is achieved by feeding a minimum of 1000 μ V of RF-signal modulated with 1000 Hz at 60% Δf max. to the receiver.

The audio output (which must be at least 100% of the receiver's audio rating) is measured through the psophometric filter, with the distortion meter in position CAL and adjusted with potentiometer ADJ. FSD. to a reading of 100.

The notch filter is then inserted in series with the audio by pressing one of the buttons marked in %. The meter needle immediately drops to indicate a low value, this being the receiver's inherent audio distortion.

By backing off the attenuator of the RF-generator thereby lowering the RF input to the receiver, the noise will eventually increase; the attenuator is now adjusted for a 10% reading on the distortion meter scale.

At this stage it must be ensured that the increased noise and the signal (with the notch filter switched out while checking) still equals 100 on the meter scale.

The RF-generator's calibrated attenuator now shows the value of RF-signal required to achieve a 20 dB ratio between signal + noise + distortion and noise + distortion, i. e. 20 dB SINAD sensitivity.

EIA Method

EIA (Electronic Industrie's Association) Standard, definition:

The SINAD sensitivity of a receiver is the minimum input signal that will provide at least 50% of the receiver's rated audio power with 12 dB signal + noise + distortion to noise + distortion.

The EIA method differs from CEPT by omitting the psophometric filter, adjusting the RF generator for $2/3 \times \Delta f_{max.}$, and measure the distortion at 50% of the receiver's rated AF power. The SINAD sensitivity is measured as a 12 dB ratio between signal + noise + distortion and noise + distortion, which corresponds to a reading of 25% noise + distortion.

ADJUSTING THE SENSITIVITY

Lower the RF generator output to obtain 20 dB SINAD (10% THD as measured with the distortion meter). Readjust L402 for the best SINAD value, e. i. lowest generator output for 10% THD.

MEASURING 20 dB SINAD (CEPT)

Adjust the volume control for 2.45 V (1.5 W/4 ohm) as measured with an AF voltmeter across the load.

Adjust the RF generator output to obtain 20 dB SINAD condition.

Read the 20 dB SINAD sensitivity (e. m. f.) Requirement: ≤ 0.75 uV.

The sensitivity should be measured on all channels, if more than one.

MEASURING 12 dB SINAD (EIA)

Adjust the volume control for 2.45 V as measured with an AF voltmeter across the load.

Adjust the RF generator to obtain 12 dB SINAD condition.

Read the 12 dB SINAD sensitivity. Requirement: ≤ 0.3 uV ($\frac{1}{2}$ e. m. f.)

The sensitivity should be measured on all channels, if more than one.

AUDIO FREQUENCY RESPONSE

Set the signal generator to Standard Test Condition.

Adjust the volume control for 0.82 V across the load. (4 ohm across (SPKR HI - LO)).

At 13.2 V supply, $\Delta F = 60\% \Delta F_{max}$ and 1000 Hz measure the output voltage according to the following table:

	Frequency	Level	Tol.
Type CQM5332 S12	300 Hz	+9 dB	+1 dB/-3 dB
	1000 Hz	0 dB	
	3000 Hz	-9.5 dB	+1 dB/-3 dB
Type CQM5333 S12	300 Hz	+10.5 dB	+1.5 dB/-3 dB
	400 Hz	+8 dB	+1.5 dB/-1.5 dB
	1000 Hz	0 dB	
	2700 Hz	-8.6 dB	+1.5 dB/-1.5 dB
	3000 Hz	-9.5 dB	+1.5 dB/-3 dB
	6000 Hz	<-20 dB	
Type CQM5334 S12	300 Hz	+9 dB	+1 dB/-3 dB
	1000 Hz	0 dB	
	2550 Hz	-8 dB	+1 dB/-3 dB

SELF QUIETING CHECK

Internal oscillators, dividers and the harmonic frequencies hereof, may cause self quieting of the receiver if a mixer product falls in the RF or IF pass band.

For proper operation of the squelch all channels must be checked for the self quieting phenomenon.

Connect the RF generator to the antenna connector. Reduce the RF output to 0. Set the frequency outside the 66 - 88 MHz band.

Alternatively, an attenuator (50 ohm) may be connected to the antenna connector.

Connect an AF voltmeter across the 4 ohm speaker load.

Adjust the volume control for 774 mV (0 dBm) as read on the AF voltmeter.

Select, in turn, all allocated channels.

The reading on the AF voltmeter shall not on any selected channel decline more than 6 dB.

Requirement: Quieting ≤ 6 dB.

AF POWER OUTPUT

Adjust the RF signal generator to Standard Test Condition.

Set the supply voltage to 13.2 V.

Adjust the volume control for 3 W output (3.46 V across the 4 ohm load).

Measure the distortion (THD).

Requirement: THD $\leq 5\%$.

SQUELCH

Release the squelch cancel button.

Adjust potentiometer R607 squelch adj. to open the receiver for an RF input signal corresponding to 8-10 dB SINAD.

The final squelch adjustment must not be set on a channel that has shown a minor degree of selfquieting.

CURRENT CONSUMPTION

Measure the current consumption at 13.2 V.

For sets with selective calling facilities add current consumption of the tone unit to the figures above.

Requirements

Condition	Current consumption
Standby	≤400 mA
Receive 2 W AF ~ 2.83 V r.m.s. across 4 ohm.	≤750 mA

TRANSMITTER ADJUSTMENT

Adjust the power supply voltage to 13.2 V and set current limiter as follows:

- 25 W transmitter: 6A
- 6 W transmitter: 4A

Refer to Receiver Alignment for measuring 8.5 V regulated supply.

Preset all transmitter tuning slugs, L151, L153, L201, L202, L204, and L205 to be flush with the coil form top.

Connect a multimeter (2.5 volt range) to test point TP201.

Turn the power control potentiometer, R221, to minimum, anticlockwise (CCW).

Connect a Wattmeter, (25 W) to the antenna connector, J601.

FREQUENCY SYNTHESIZER ALIGNMENT

Check the PROM U801, the TX mixer crystal, the RX mixer crystal, and the reference crystal and verify the frequencies and the prom codes.

Mixer crystal output

Connect RF probe 95.0089-00 with multimeter to test point TP701 (1 V range).

Key the transmitter.

Adjust L701 for maximum deflection on the multimeter.

Adjust L704 for maximum deflection on the multimeter.

Requirement:

250 mV ± 125 mV

(corresponding to -10 dBm to -4 dBm)

Note: Be careful not to resonate L704 to the false harmonics. If in doubt con-

sult table 1 or check the crystal oscillator output with a spectrum analyzer.

Transmitter VCO

Connect the oscilloscope to test point TP706.

The oscilloscope measures the synthesizer's lock signal which is +8 volts with very narrow negative going pulses when in locked position. Unlocked condition is indicated by a variable duty signal or logic "low".

Typical trace for locked condition

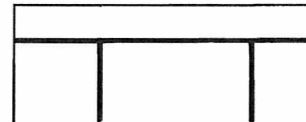

The pulse repetition rate is 10 or 12.5 kHz corresponding to the channel spacing respectively. Select the channel whose frequency is closest to the center frequency.

Adjust C745 for as narrow pulses as possible.

Connect the multimeter to test point TP703.

Adjust C745 for 4.0 volt on the multimeter.

If the radio has more than one channel adjust C745 so that the multimeter reading for all channels are evenly distributed around 4.0 volt. The high channel frequency shall give a voltage reading above 4.0 volt equal to the low channel reading below 4.0 volt.

Example:

High channel reading: 5.1 volt (4.0 + 1.1)

Center channel reading: 4.0 volts

Low channel reading: 2.9 volt (4.0 - 1.1)

The deviation of the voltage reading from 4.0 volts depends on the spread of the high and low channel.

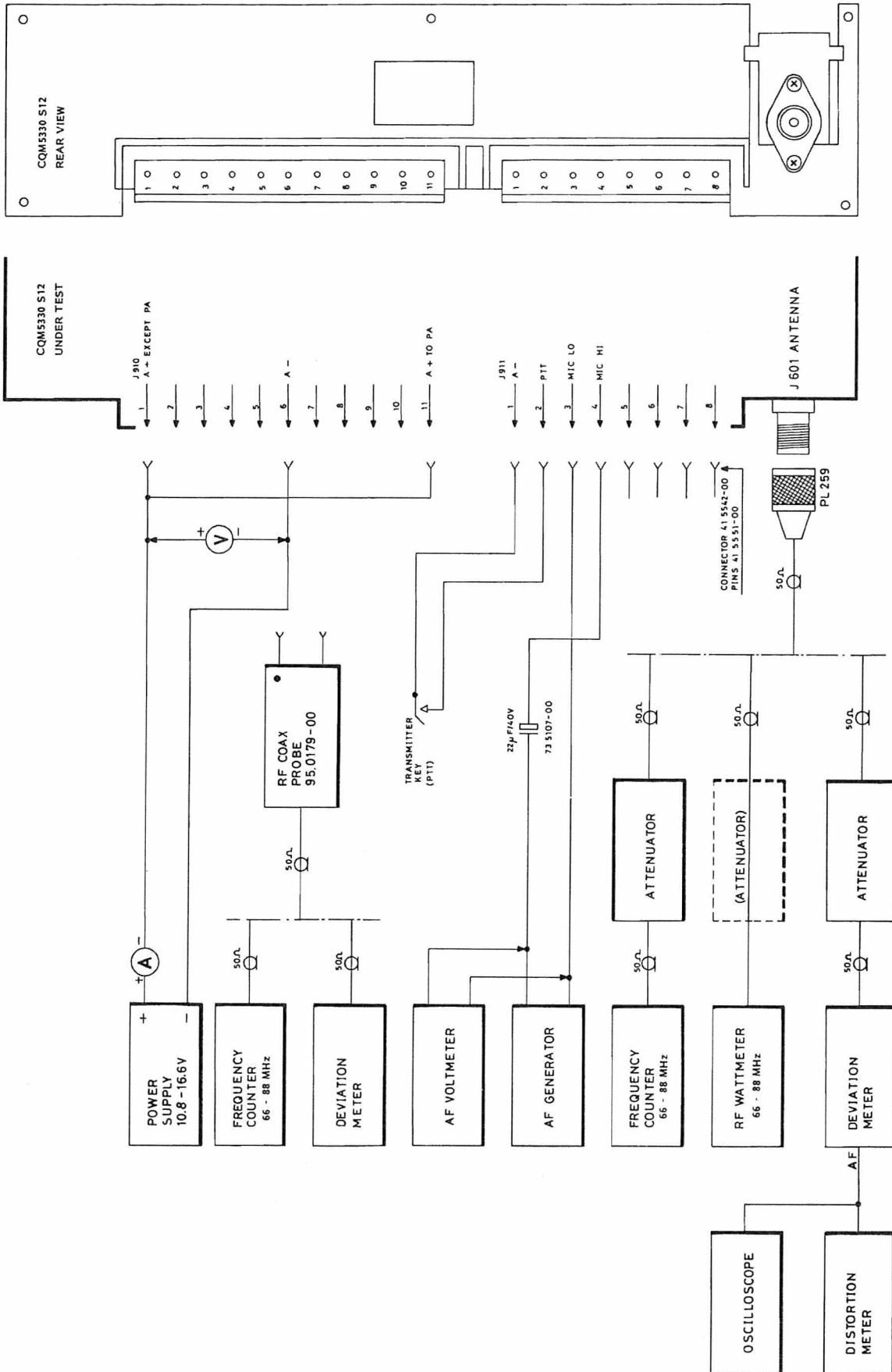

TRANSMITTER TEST SET-UP

CQM5330 S12

D402.883

Mixer Crystal Frequency

Connect coax probe 95.0179-00 to test point TP701.

Connect the frequency counter to the probe, key the transmitter and read the frequency.

$$f = f_x \times 4 \quad (f_x = \text{crystal frequency}).$$

Adjust L701 to the calculated frequency.

Requirement: $f \pm 0.3 \text{ ppm}$ at 25°C .

ppm = parts per million = 10^{-6} .

Synthesizer Output Level

Connect a multimeter, 2.5 V range, to test point TP201. Key the transmitter.

Adjust L153 for maximum deflection on the multimeter, typical more than 0.75 V.

EXCITER

Coarse adjustment

Connect a multimeter (2.5 V range) to test point TP201. Key the transmitter.

Adjust L153 for maximum deflection.

Adjust L201 for minimum deflection. The dip is small

Connect the multimeter (2.5 V range) to test point TP202.

Adjust L202 for maximum deflection on the multimeter, typical 1.0 V.

Adjust L204 for minimum reading. The dip is small.

Connect diode probe 95.0089-00 and the multimeter (25 V range) to test point TP203.

Adjust L204 and L205 for maximum reading on the multimeter, typical 15 V.

Adjust the PA power control, R221, for rated transmitter power, 6/10 W or 25 W.

Fine adjustment

Connect the multimeter to test point TP201. Key the transmitter.

Readjust L153 for maximum reading.

Connect the multimeter to test point TP202.

Peak L201 and L202 for maximum reading.

If the maximum is not well defined detune

L153 slightly, adjust L201 and L202, and repeat the adjustment of L153.

Connect the 95.0089-00 RF probe and multimeter to test point TP203.

Peak L204 and L205 for maximum reading.

TRANSMITTER FREQUENCY ADJUSTMENT

Connect a frequency counter through a suitable attenuator to the antenna connector J601.

Key the transmitter.

Select one by one, the channels and read their frequencies.

Adjust L701 for best frequency tracking on all channels.

Requirement: $F = F_{\text{ant}} \pm 0.4 \text{ ppm}$,

ppm = parts per million = 10^{-6}

RF POWER OUTPUT, CURRENT CONSUMPTION, AND POWER CONTROL

Connect the Watt meter to the antenna connector, J601.

Increase the supply voltage to 16 V. The voltage is measured directly at the input connector J910.

Readjust the PA power control, R221, for rated transmitter power (P), 6(10) or 25 W.

Requirement: $P_{\text{nom}} \pm 0.1 \text{ dB}$.

Measure the RF power output at 16 V, 13.2 V and 10.8 V.

Requirements (25 W):

Voltage	Power	Current
16.6 V	25 W (ref)	$\leq 5.8 \text{ A}$
13.2 V	$\geq 23.5 \text{ W}$	$\leq 5.8 \text{ A}$
10.8 V	$\geq 20 \text{ W}$	$\leq 5.8 \text{ A}$

Requirements (6 W):

Voltage	Power	Current
16 V	6 W (ref)	$\leq 2.6 \text{ A}$
13.2 V	$\geq 5.2 \text{ W}$	$\leq 2.6 \text{ A}$
10.8 V	$\geq 5.0 \text{ W}$	$\leq 2.6 \text{ A}$

MODULATION ADJUSTMENT

Set the power supply voltage to 13.2 V.
 Select the channel having the highest frequency. Set R116 to mid-position.
 Connect coax probe 95.0179-00 to test point TP701.

Connect a deviation meter to the coax probe.

Connect a distortion meter and oscilloscope to the deviation meter output.

Connect a AF generator and an AF Voltmeter to the microphone input via a 22 μ F capacitor; refer to test setup.

Set the AF generator to 1000 Hz.

Adjust the AF generator output to 1 V r. m. s. This voltage is approx. 20 dB above the nominal modulation input level (60% Δf max) to ensure full limiting in the modulation processor.

Note the deviation read at TP701.

Connect the deviation meter to test point TP702.

Adjust R752 (Dev. Bal.) for same deviation as measured at TP701.

Connect the deviation meter through an attenuator to the antenna connector, J601.

Connect a distortion meter and oscilloscope to the deviation meter output.

Connect an AF generator and an AF Voltmeter to the microphone input via a 22 μ F capacitor; refer to test setup.

Set the AF generator to 1000 Hz.

Adjust the AF generator output to 1 V r. m. s. This voltage is approx. 20 dB above the nominal modulation input level (60% Δf max) to ensure full limiting in the modulation processor.

Find the AF frequency between 200 Hz and 3000 Hz giving the greatest frequency deviation as read on the deviation meter with the transmitter keyed.

Check the maximum deviation for both positive and negative deviation polarity. At that audio frequency set the maximum frequency deviation Δf max with R116.

Type	Channel spacing	Δf max
CQM5332 S12	30/25 kHz	± 5 kHz
CQM5333 S12	20 kHz	± 4 kHz
CQM5334 S12	12.5 kHz	± 2.5 kHz

Requirement

Difference between + and - deviation: $\leq 10\%$

MODULATION SENSITIVITY AND MODULATION DISTORTION

Set the AF generator frequency to 1000 Hz
 Adjust the generator output until 60% of Δf max is obtained on the deviation meter.

CQM5332 S12 : ± 3.0 kHz

CQM5333 S12 : ± 2.4 kHz

CQM5334 S12 : ± 1.5 kHz

Read the AF generator output and measure the modulation distortion on the audio output of the deviation meter.

Requirements:

Modulating signal: 75 mV ± 3 dB

Distortion: $\leq 7\%$

(measured without deemphasis)

MODULATION FREQUENCY RESPONSE

Set the AF generator to 1000 Hz.

Reduce the AF generator output until a deviation of $0.2 \times \Delta f$ max is obtained on the deviation meter.

CQM5332 S12 : ± 1.0 kHz

CQM5333 S12 : ± 0.8 kHz

CQM5334 S12 : ± 0.5 kHz

Vary the frequency of the generator and note the deviation changes as referred to the 1000 Hz value.

Requirement :

Within the frequency range 400-2700 Hz the frequency characteristic shall lie within +1 dB/-1.5 dB related to a 6 dB/octave characteristic.

With 6 kHz modulation frequency the deviation shall be attenuated at least 6 dB below the 1 kHz value.

ADJUSTMENT OF TONE EQUIPMENT

Measuring equipment

Tone Test Generator Storno TS-G13
95B0251-00

Check the connections and the tone combination of the TQ5001/TQ5002/TQ5004/TQ5005 and SU/5002; refer to description and diagrams.

Adjustment of frequency deviation

Apply Standard test condition to the transmitter; refer to transmitter test setup. Establish a shortcircuit between emitter and collector of Q108, on the solderside

of the TQ unit, which will produce a continuous tone to the modulator.

Key the transmitter using the tone button.

Adjust R113, TQ5001/TQ5002/TQ5004/TQ5005 for 70% of maximum frequency deviation.

Remove the short circuit.

Connect the G13 Tone Test set to the AF output on the Deviation Meter.

Check that the tone call is properly received when the tone button is depressed.

Checking the Tone Receiver

Apply Standard test condition to the receiver; refer to receiver test setup.

Modulate the signal generator with the G13 Tone Test Set.

Set the G13 to the proper tone combination.

Check that the TQ unit responds to a released tone call.

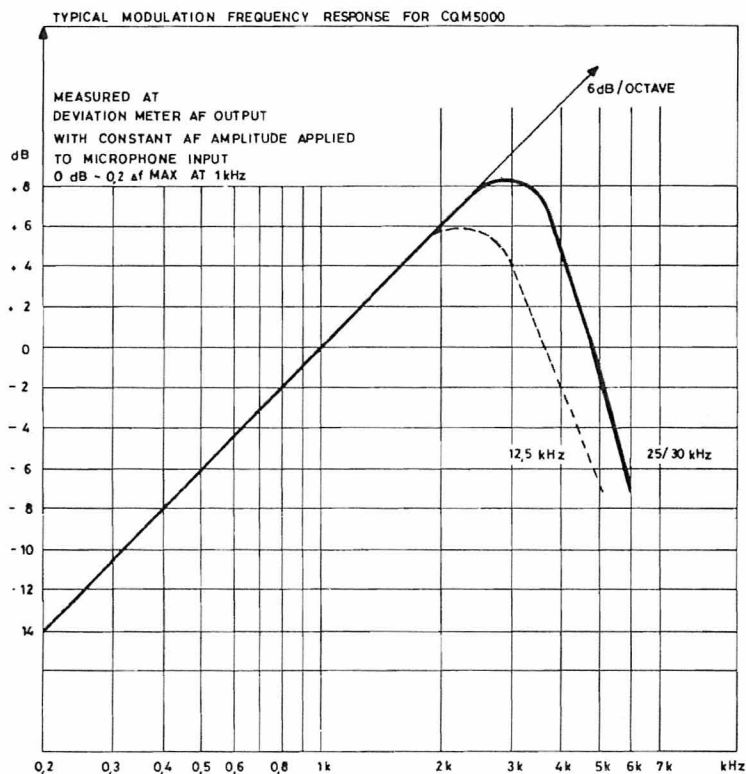

CHANNEL PROGRAMMING INSTRUCTIONS

CQM5330 S12

Programming of the PROM which contains the data for the channel frequencies will normally be part of the factory process, but it may also be field programmed.

The PROM programming unit must be approved by the PROM manufacturer, as for example (DATA I/O SYSTEM 17 or 19).

The programmer consists of the following items:

Programmer (DATA I/O SYSTEM 19)

Programming Pak, interchangeable

Socket adaptor

or universal programming pack.

DATA I/O UNIPAK (adaptable for more than 200 types of PROM devices).

To program a PROM the channel frequencies for all allocated channels and the channel spacing must be known.

It is recommended to complete a worksheet when calculating the prom data.

It is also possible to use a computer to calculate the prom data and Storno will be able to supply software programs for certain types of computers.

Operating instructions for the Programmer is supplied by the vendor.

WORKSHEET

For each PROM to be programmed a worksheet should be completed to calculate the input data for each channel.

The procedure for completing the worksheet is:

1. Complete list of receiver channel frequencies. (A).
2. Complete list of transmitter channel frequencies. (B).
3. Find highest (H) and lowest (L) receiving frequencies.
4. Find highest (H) and lowest (L) transmitting frequencies.
5. Select receiver mixer crystal frequency (C) from table 1. The highest and lowest receiver frequencies must be within the selected band.
6. Select transmitter mixer crystal frequency (D) from table 2. The highest and lowest transmitter frequencies must be within the selected band.
7. Note channel spacing and Reference frequency (F). See worksheet.
8. Use receiver formula to calculate " V_{DEC} " (divisor) for all receiver channels.
9. Use transmitter formula to calculate " V_{DEC} " (divisor) for all transmitter channels.
10. Check " V_{DEC} " for all channels to be between 256 and 511.
11. Use receiver crystal frequency and V_{DEC} to check for selfquieting frequencies, table 3.
12. In case of selfquieting select appropriate alternative and possibly recalculate "V".
13. Convert all " V_{DEC} " numbers to hexadecimal code. Refer to tabel 4.
14. Assign the hexadecimal codes to the corresponding channels and the PROM addresses.

After completing the worksheet the next steps are:

1. Enter correct Prom addresses and corresponding data (V_{HEX}) on the Programmer (DATA I/O), refer to Programmer Operating Instructions.
2. Insert the channel knob stop (if needed) if less than 9 channels, refer to fig. 1.
3. In case of more than 8, but less than 12 channels are used, transmission on unauthorized channels must be avoided. This is done by burning the unused channel locations in the PROM with the highest channel HEX CODE.

CHANNEL STOP

LOWEST CH.	INSERT PIN BETWEEN	HIGHEST CH.	INSERT PIN BETWEEN
1	10 and 11	1	3 and 4
2	11 and 12	2	4 and 5
3	12 and 1	3	5 and 6
4	1 and 2	4	6 and 7
5	2 and 3	5	7 and 8
6	3 and 4	6	8 and 9
7	4 and 5	7	9 and 10
8	5 and 6	8	10 and 11
9	6 and 7	9	11 and 12
10	7 and 8	10	12 and 1
11	8 and 9	11	1 and 2
12	9 and 10	12	2 and 3

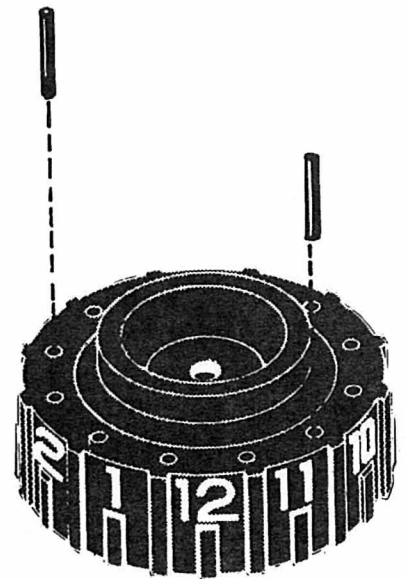

Note: If 8 channels are used insert only one PIN.
If more than 8 channels are used stop is not possible and no PINs are inserted.

Fig. 1. SETTING OF CHANNEL KNOB STOP.

RECOMMENDED CRYSTAL FREQUENCIES
CQM5330

CQM5332 - CQM5334 FREQUENCY RANGE	CQM5333 FREQUENCY RANGE	RX CRYSTAL
65.2 - 68.3875	64.56 - 67.11	36.35
66.2 - 69.3875	65.56 - 68.11	36.85
67.2 - 70.3875	66.56 - 69.11	37.35
68.2 - 71.3875	67.56 - 70.11	37.85
69.2 - 72.3875	68.56 - 71.11	38.35
70.2 - 73.3875	69.56 - 72.11	38.85
71.2 - 74.3875	70.56 - 73.11	39.35
72.2 - 75.3875	71.56 - 74.11	39.85
73.2 - 76.3875	72.56 - 75.11	40.35
74.2 - 77.3875	73.56 - 76.11	40.85
75.2 - 78.3875	74.56 - 77.11	41.35
76.2 - 79.3875	75.56 - 78.11	41.85
77.2 - 80.3875	76.56 - 79.11	42.35
78.2 - 81.3875	77.56 - 80.11	42.85
79.2 - 82.3875	78.56 - 81.11	43.35
80.2 - 83.3875	79.56 - 82.11	43.85
81.2 - 84.3875	80.56 - 83.11	44.35
82.2 - 85.3875	81.56 - 84.11	44.85
83.2 - 86.3875	82.56 - 85.11	45.35
84.2 - 87.3875	83.56 - 86.11	45.85
85.2 - 88.3875	84.56 - 87.11	46.35
86.2 - 89.3875	85.56 - 88.11	46.85
87.2 - 90.3875	86.56 - 89.11	47.35
88.2 - 91.3875	87.56 - 90.11	47.85

TABLE 1. RECEIVER MIXER CRYSTAL FREQUENCY

RECOMMENDED CRYSTAL FREQUENCIES

CQM5330

CQM5332 – CQM5334 FREQUENCY RANGE	CQM5333 FREQUENCY RANGE	TX CRYSTAL
65.2 – 68.3875	64.56 – 67.11	15.5
66.2 – 69.3875	65.56 – 68.11	15.75
67.2 – 70.3875	66.56 – 69.11	16.
68.2 – 71.3875	67.56 – 70.11	16.25
69.2 – 72.3875	68.56 – 71.11	16.5
70.2 – 73.3875	69.56 – 72.11	16.75
71.2 – 74.3875	70.56 – 73.11	17.
72.2 – 75.3875	71.56 – 74.11	17.25
73.2 – 76.3875	72.56 – 75.11	17.5
74.2 – 77.3875	73.56 – 76.11	17.75
75.2 – 78.3875	74.56 – 77.11	18.
76.2 – 79.3875	75.56 – 78.11	18.25
77.2 – 80.3875	76.56 – 79.11	18.5
78.2 – 81.3875	77.56 – 80.11	18.75
79.2 – 82.3875	78.56 – 81.11	19.
80.2 – 83.3875	79.56 – 82.11	19.25
81.2 – 84.3875	80.56 – 83.11	19.5
82.2 – 85.3875	81.56 – 84.11	19.75
83.2 – 86.3875	82.56 – 85.11	20.
84.2 – 87.3875	83.56 – 86.11	20.25
85.2 – 88.3875	84.56 – 87.11	20.5
86.2 – 89.3875	85.56 – 88.11	20.75
87.2 – 90.3875	86.56 – 89.11	21.
88.2 – 91.3875	87.56 – 90.11	21.25

TABLE 2. TRANSMITTER MIXER CRYSTAL FREQUENCY

SELFQUIETING FREQUENCIES

CQM5332

RECEIVER CRYSTAL FREQUENCY, MHz	V DEC	USE ALTERNATIVE ⁺
All crystal frequencies	428	1
38.35	457	2
38.85	377	2
39.35	297	2
40.85	464	3
41.35	384	3
41.85	304	3
43.35	474	2
43.85	397	2
44.35	314	2

TABLE 3A. SELFQUIETING FREQUENCIES

⁺refer to worksheet

SELFQUIETING FREQUENCIES

CQM5333

RECEIVER CRYSTAL FREQUENCY, MHz	V DEC	USE ALTERNATIVE ⁺
38.85	468	3
38.85	471	2
39.35	368	3
39.35	371	2
39.85	268	3
39.85	271	2
43.85	492	3
43.85	496	2
44.35	392	3
44.35	396	2
44.85	292	3
44.85	296	2

TABLE 3B. SELFQUIETING FREQUENCIES

⁺refer to worksheet

HEX CODE CONVERSION TABLE

		Least Significant Digit (LSD) of Hex Code															
		0	1	2	3	4	5	6	7	8	9	A	B	C	D	E	F
Most Significant Digit of Hex Code.	0	256	257	258	259	260	261	262	263	264	265	266	267	268	269	270	271
	1	272	273	274	275	276	277	278	279	280	281	282	283	284	285	286	287
	2	288	289	290	291	292	293	294	295	296	297	298	299	300	301	302	303
	3	304	305	306	307	308	309	310	311	312	313	314	315	316	317	318	319
	4	320	321	322	323	324	325	326	327	328	329	330	331	332	333	334	335
	5	336	337	338	339	340	341	342	343	344	345	346	347	348	349	350	351
	6	352	353	354	355	356	357	358	359	360	361	362	363	364	365	366	367
	7	368	369	370	371	372	373	374	375	376	377	378	379	380	381	382	383
	8	384	385	386	387	388	389	390	391	392	393	394	395	396	397	398	399
	9	400	401	402	403	404	405	406	407	408	409	410	411	412	413	414	415
	A	416	417	418	419	420	421	422	423	424	425	426	427	428	429	430	431
	B	432	433	434	435	436	437	438	439	440	441	442	443	444	445	446	447
	C	448	449	450	451	452	453	454	455	456	457	458	459	460	461	462	463
	D	464	465	466	467	468	469	470	471	472	473	474	475	476	477	478	479
	E	480	481	482	483	484	485	486	487	488	489	490	491	492	493	494	495
	F	496	497	498	499	500	501	502	503	504	505	506	507	508	509	510	511

"V_{DEC}" Numbers.

Example "V_{DEC}"= 345 equals to hex code 59. ↖ MSD
↘ LSD

"V_{DEC}"= 469 equals to hex code D5.

Table 4.
"V" Number to hex code conversion table.



PROGRAMMING WORKSHEET



FOR CQM5330 S12

RECEIVER						TRANSMITTER					
CHAN- NEL	A FREQUENCY MHz	L H	V DEC	V HEX	PROM ADDRESS, (HEX)	B FREQUENCY MHz	L H	V DEC	V HEX	PROM ADDRESS (HEX)	
1					00					10	
2					01					11	
3					02					12	
4					03					13	
5					04					14	
6					05					15	
7					06					16	
8					07					17	
9					08					18	
10					09					19	
11					0A					1A	
12					0B					1B	

RECEIVER MIXER CRYSTAL FREQ. (Y702): C= _____

TRANSMITTER MIXER CRYSTAL FREQ. (Y701) D= _____

FORMULA: $V_{DEC} = \frac{(A + 10.7) - (C \times 2)}{F}$

FORMULA: $V_{DEC} = \frac{B - (D \times 4)}{F}$

CHANNEL SPACING:	REFERENCE CRYSTAL (Y703):	REFERENCE FREQUENCY:
20 kHz	10.240000 MHz	F= 0.01
12.5/25 kHz	12.800000 MHz	F= 0.0125

LIST OF REFERENCE CRYSTALS (Y703)

ALTERNATIVE SOLUTIONS IF THE RECEIVER IS SELFQUIETING:

MODE	FREQUENCY, MHz	PART No.
Standard 5332/5334	12.800000	19J06361P1
Offset 5334	12.801000	19J06361P7
Offset 5332	12.802000	19J06361P8
Standard 5113	10.240000	19J06361P2
Offset 5333	10.241300	19J06361P10

1. SELECT ANOTHER RX MIXER CRYSTAL FREQUENCY
2. SELECT HIGH INJECTION FREQUENCY FOR 2nd OSCILLATOR
Y501= 11.15500 MHz INSTEAD OF 10.245000 MHz
3. USE SLIGHTLY OFFSET REFERENCE CRYSTAL
4. WEAK QUIETING; NO ALTERNATIVE REQUIRED

TECHNICAL SPECIFICATIONS

CQM5330 S99

Guaranteed performance specifications unless otherwise noted.

Typical values are given in brackets.

GENERAL

Frequency Range

66 - 88 MHz

Antenna Impedance

50 ohm

Channel Separation

CQM5332: 30/25 kHz

CQM5333: 20 kHz

CQM5334: 12.5 kHz

Maximum number of channels

99

Maximum Frequency Deviation

CQM5332: ± 5 kHz

CQM5333: ± 4 kHz

CQM5334: ± 2.5 kHz

Supply Voltage

Minimum: 10.8 V

Nominal: 13.2 V

Maximum: 16.6 V

Modulation Frequency Range

CQM5332: 300 - 3000 Hz

CQM5333: 300 - 3000 Hz

CQM5334: 300 - 2550 Hz

Temperature Range

-30°C to $+60^{\circ}\text{C}$

Dimensions

B x D x H: 180 x 190 x 60 mm

Maximum RF Bandwidth

RX: 1.5 MHz

TX: 2.5 MHz

Weight

1.8 kg.

RECEIVER

Sensitivity

12 dB SINAD (EIA), $\frac{1}{2}$ e. m. f. :

0.3 μV (0.25 μV)

EIA measuring conditions:

$\Delta f = \pm 2/3 \Delta f$ max: $f_{\text{mod}} = 1$ kHz

20 dB SINAD (CEPT), e. m. f. :

CQM5332: 0.75 μV (0.55 μV)

CQM5333: 0.75 μV (0.55 μV)

CQM5334: 1.0 μV (0.75 μV)

CEPT measuring conditions:

$\Delta f = 60\% \Delta f$ max: $f_{\text{mod}} = 1$ kHz

Measured with psophometric filter

Crystal Frequency Range

38.35 - 49.35 MHz

Receiver VCO Frequency Range

77 - 99 MHz

Frequency Stability

Conforms with governments regulations

Modulation Acceptance BandwidthCQM5332: ± 5 kHz (± 5.8 kHz)Adjacent Channel Selectivity

EIA

CQM5332: 75 dB (85 dB)

FTZ

CQM5333: 70 dB (85 dB)

CEPT

CQM5332: 75 dB (85 dB)

CQM5334: 65 dB (85 dB)

Spurious Rejection EIA

80 dB (85 dB)

Intermodulation Attenuation

EIA

CQM5332: 70 dB (72 dB)

FTZ

CQM5333: 70 dB (72 dB)

CEPT

CQM5332: 70 dB (75 dB)

CQM5333: 70 dB (75 dB)

CQM5334: 70 dB (73 dB)

Radiation

Conducted: max. 0.8 nW

Radiated: max. 0.8 nW

Blocking

90 dB/uV (104 dB/uV)

AF Load Impedance (Loudspeaker)

4 ohm

AF Power Output

3 W (3.6 W)

AF Distortion

5% (1.5%)

60% Δf max., 1 kHz, 1 W, RF 1 mVAudio Frequency Response CEPT/FTZfm: 300 - 3000 Hz (CEPT)
+1/-3 dB (+0/-1.5 dB)fm: 400 - 2700 Hz (FTZ)
+1/-1.5 dB (+0/-1 dB)fm: 300 - 2550 Hz
+1/-3 dB (+0/-1 dB)

Relative to 1000 Hz, -6 dB/octave

Hum and Noise

Squelched: 80 dB (better than 85 dB)

Unsquelched: 55 dB (57 dB)

Squelch Attack Time (EIA)

150 ms (110 ms)

Squelch Recovery Time

250 ms (200 ms)

Squelch Closing Time (EIA)

150 ms (50 ms)

Current Consumption

Squelched: 1000 mA (750 mA)

Receive, AF 2 W: 1450 mA (1150 mA)
(13.2 V supply)

TRANSMITTER

RF Power Output

CQM5332-6: 6 W

CQM5332-25: 25 W

CQM5333-6: 6 W

CQM5333-25: 25 W

CQM5334-6: 6 W

CQM5334-25: 25 W

(R_L = 50 ohm)

Crystal Frequency Range

15.5 - 21.25 MHz

Crystal Frequency Multiplication

x 4

Transmitter VCO Frequency Range

66 - 88 MHz

Frequency Stability

Conforms with government regulation

Undesired Radiation

max. 0.2 uW

Sideband Noise Power, CEPT

less than 70 dB

Modulation AF Input Impedance

560 ohm

Modulation Sensitivity70 mV \pm 2 dB(60% Δf max., 1 kHz)Modulation Response

300 - 3000 Hz (CEPT)

+1/-3 dB (+0.5/-2 dB)

relative to 1000 Hz, 6 dB/octave

400 - 2700 Hz (FTZ)

+1/-1.5 dB (+0.5/-1 dB)

relative to 1000 Hz, 6 dB/octave

300 - 2550 Hz

+1/-3 dB (+0.5/-2 dB)

Relative to 1000 Hz, 6 dB/octave

Modulation Distortion (CEPT)

max. 3%

 $f_{mod} = 1000$ Hz, $\Delta f = 60\% \Delta f$ max.

max. 5%

 $f_{mod} = 300$ Hz, $\Delta f = 5.5\% \Delta f$ max.

measured with 750 usec. de-emphasis

FM Hum and Noise, CEPT

55 dB (57 dB)

measured with 750 usec. de-emphasis

Attack Time

50 ms

Current Consumption

6 W: less than 3.7 A (3 A)

25 W: less than 6.6 A (5.5 A)

GENERAL DESCRIPTION

CQM5330 S99

The Stornophone 5000 is a mobile radiotelephone unit with self-contained controls keyboard and display.

A comparison of the various models are presented in the table below.

Although compact in size, it contains a transmitter/receiver, a microcomputer controlled synthesizer and tone equipment, optional 5-tone sequential encoder/decoder or Channel Guard, and up to 99 transmit and receive channels.

Type	CQM5332 S99		CQM5333 S99		CQM5334 S99	
SPEC	6/10	25	6/10	25	6/10	25
Frequency Range MHz	6 - 88		6 - 88		6 - 88	
RF Power W	6/10	25	6/10	25	6/10	25
Channel Spacing kHz	30/25		20		12.5	
Max. Number of Channels	99		99		99	

ACCESSORIES

Standard accessories include:

Mounting frame

Power cable

Fist microphone with retainer or

Fixed - mount microphone

External loudspeaker

External switches

MN5001 Mounting frame for mobile installations allowing the radio to be fixed in 36 positions. Includes a base plate with locking screw.

MN703 Desk stand for fixed installations.

MN704a Mounting frame for mobile installations and direct attachment to the vehicle.

MC5001 Fist microphone with retractable spiral cable for mobile installation.

HS5001 Retainer for MC5001.

HS5002 Retainer, with switches, for MC5001

MC704 Microphone with chockabsorbing mounting bracket for mobile installation.

MC703 Desk microphone with PTT switch for fixed installations.

MK5001 Installation kit containing connectors, power cable, fuses and fuseholders.

LS701 Loudspeaker enclosed in a plastic housing, complete with cable.

SU701 Transmitter keying switch for mounting on the steering column.

SU702 Transmitter keying switch for mounting on the dashboard.

PS702 Power supply regulator for 24 V car battery installations.

PS5001 Power supply for 220 V AC mains.

MECHANICAL AND ELECTRICAL DESCRIPTION

The internal construction of CQM5000 is on an H-frame chassis with a shelf separating the receiver/transmitter (RF) printed circuit board and the various option printed boards. Front panel controls, display and keyboard are an integral part of the Control Panel.

The chassis is a die cast aluminium frame comprising the left and right sides, the back, and a shelf located midway between the top and bottom. The chassis front is open and looks like an "H" viewed from the front.

Interconnection to the package exterior and to internal options are made via the Frequency Synthesizer Board located on the option side of the H-frame. A test connector is also located on the synthesizer board and is accessible from the rear of the radio.

The moulded plastic front is directly attached to the chassis and has the speaker mounted to it. A separate moulded control panel and aluminum nameplate are attached to the front.

The top and bottom covers slides under the edge of the front and are then secured by screws at the rear.

The tone signalling encoder/decoder board (TQ), the Frequency Synthesizer Board (FB), and the Control Logic (CL) mount in the top section of the chassis.

Thin casted shields with adjustment holes are placed over the RF board and the synthesizer board in order to reduce spurious radiation.

RECEIVER DESCRIPTION

The receiver circuitry is placed on the RF board and can be divided into:

Receiver front end

1st IF section with first and second oscillator
455 kHz 2nd IF portion with demodulator,
Squelch
Audio Amplifier

(refer to functional block diagram)

FONT-END

The receiver front-end consists of a dual-resonator input filter, a transistor RF amplifier, Q401, a triple-resonator intermediate filter and a FET mixer, Q402. The drain of the FET

is terminated in the first IF resonant circuit which adapts the output impedance to the crystal filter. The front-end, antenna relay, first mixer and part of the transmitter PA interconnections are designed in micro-stripline techniques on the mainboard.

1st IF

The first IF frequency is 10.7 MHz. The output from the crystal filter is fed to a dual-gate MOSFET amplifier, Q501, the output signal of which is fed to the second mixer, U501, a single balanced, self-oscillating, active mixer. Out of the second mixer comes the 455 kHz IF signal. Two diodes, D501-502, limit the output from the mixer.

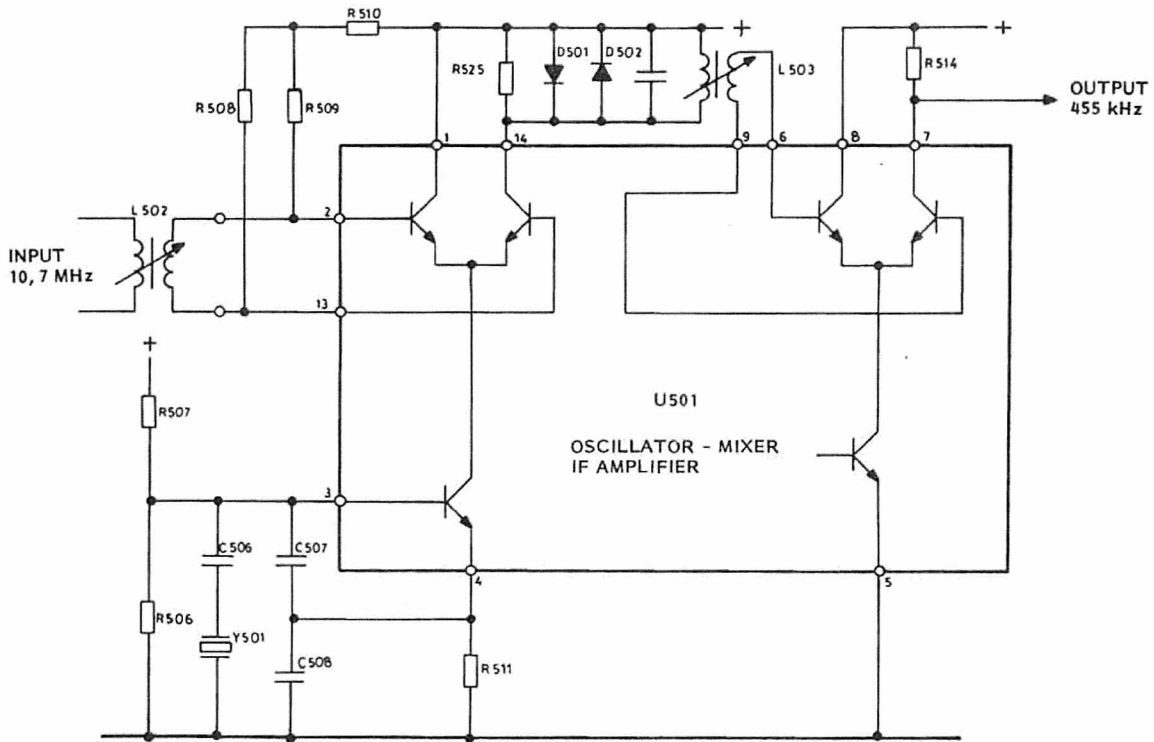

FIG. 1. SECOND OSCILLATOR , IF MIXER , AND IF AMPLIFIER

455 kHz IF/DEMODULATOR

The selectivity of the 455 kHz IF amplifier is formed by a ceramic filter fed from a 455 kHz amplifier/impedance transforming stage. The

final 455 kHz amplification and limiting is performed by an integrated circuit , U502, which also contains the quadrature FM detector and the AF amplifier/output emitter follower for the audio line signal.

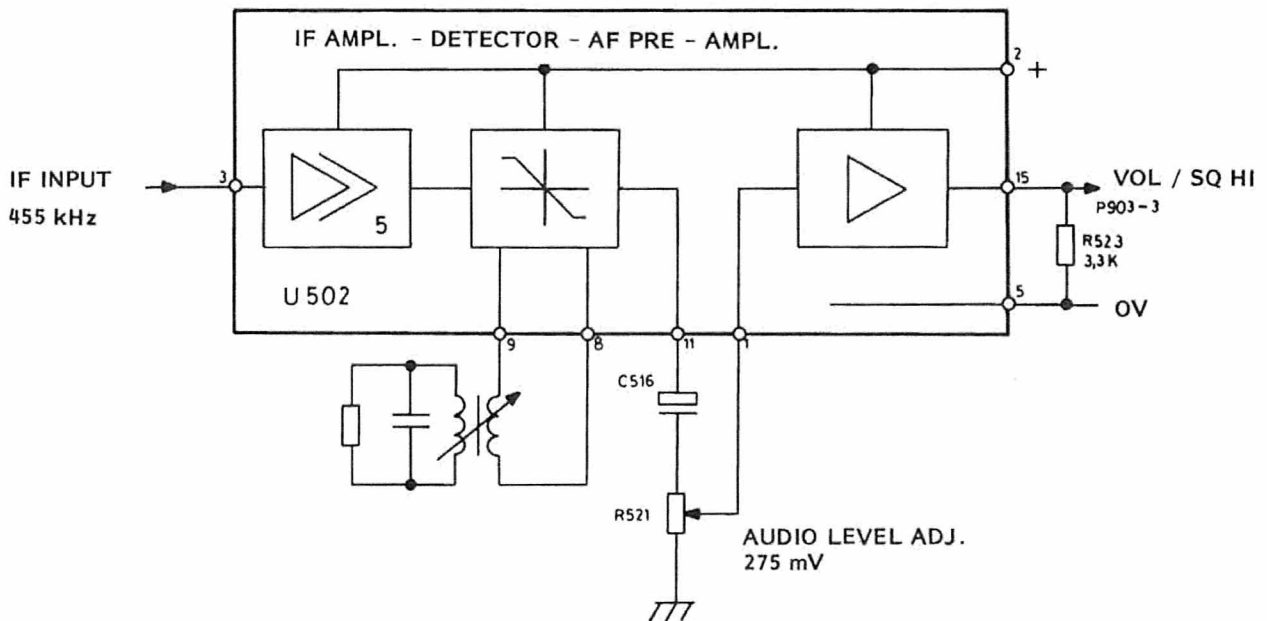

FIG. 2. IF AMPLIFIER , DETECTOR , AND AF PREAMPLIFIER

SQUELCH AND AUDIO CIRCUITS

The audio line signal (Vol/Sq - HI) is fed to a selective amplifier stage, where noise (frequencies around 8 kHz) is extracted from the audio signal. Via the squelch potentiometer R607, this signal reaches an expander stage which improves the level discrimination characteristics of the circuit. A passive voltage doubler circuit (D603-D604) with high source impedance performs the action of an average value rectifier. A Schmitt Trigger gives the necessary hysteresis and a well-defined output from the following buffer stage, Q605. In the squelched condition and during transmissions this output is +1.5 V and mutes the audio power amplifier. The transmit indicator is part of the muting function.

A push button switch, S601, cancels the squelch function, when depressed, by grounding the base of Q601.

AUDIO

In sets with Pilot tone option (CG), the audio line signal is fed to the Pilot tone board for filtering and back to the main board. In sets

without CG this path is bypassed and the audio line signal is fed directly to the passive deemphasis network R629-C608 followed by the volume control. The volume control potentiometer R630 is mounted directly on the RF board and protrude through the front panel. The audio output amplifier U601 is a monolithic IC package capable of driving the loudspeaker at the desired power level. The output amplifier can be muted with a DC signal from the audio mute gate, which combines different logic signals to decide whether the amplifier should be active or not. These inputs are:

- Regulated TX Voltage
- Squelch cancel
- Squelch signal

In sets equipped with Pilot tone and/or 5-tone sequential option, an RX mute function is routed from the option board to make the extra mute conditions possible. The value of C610 in the feed back loop is chosen as the best compromise between battery ripple rejection and receiver squelch attack time.

The pilot lamp in the channel knob is supplied from A+, but controlled by the regulated 8.5 V via transistor Q968.

TRANSMITTER

The transmitter consists of a modulation processor, an exciter, and a power amplifier, all assembled on the RF board along with the receiver.

The exciter contains, an audio processor, all frequency multiplier functions, and includes those stages operating at low enough power levels to avoid heat sinks. The exciter output is at the carrier frequency when applied to the power amplifier. The power amplifier boosts the signal to the proper level, and includes a low pass filter for suppressing harmonics and a circuitry which permits adjust-

ment of the operating power level. The PA low pass filter connects to the antenna relay via a stripline on the board.

MODULATION PROCESSOR

The signal from the microphone load R901 on the FS board is applied to amplifier U101b. The transmitter audio frequency response is shaped by the feedback network R104-R103-C104.

The modulation limiting is obtained in the feedback network formed by D101, D102, R105,

R106 and R107. The maximum permissible frequency deviation is set by a DEV. BAL. potentiometer on the FS board.

Amplifier U101A is operated as an active low-pass splatter filter feeding the modulating input of the VCO on the Frequency Synthesizer board.

EXCITER

The exciter takes the synthesized signal, filters it to reduce spurious signals and amplifies it. Four amplifier stages (Q201-2-3-4) and four filters (L204-5-8-9) are used in a narrow band design which limits the maximum frequency spread of the transmitter. The exciter has three test points (TP201-2-3) for measurements and alignment.

POWER AMPLIFIER

The PA is constructed on the main board and employs two broadband untuned amplifier stages Q205, Q206. Two amplifier configurations are available providing options of power levels of 10 watts or 25 watts. A power control circuit is included to sense the output RF level and keep it constant with variations in temperature and supply voltage. This circuit also limits the peak power to less than maximum, as specified by the authorities, while still maintaining the output as near maximum as possible. The output power level can be set with a potentiometer, R215, over at least a 3:1 range. The transmitter delivers rated power into a 50-ohm load. A load SWR of 1.4:1 will result in more than 90% of the power being radiated. The transmitter will operate into a load with up to 3:1 SWR.

The power adjustment is achieved by controlling the supply voltage of power amplifier Q205 via transistor Q207. This series transistor is biased by a voltage generated by the feedback network C255, D201, Q210, Q209, Q208.

FREQUENCY SYNTHESIZER AND CONTROL LOGIC

The frequency synthesizer FS5331 provides up to 99 channels and is built on a printed wiring board which mounts in the top section of the radioset.

The frequency of the synthesizer board is set by a binary code from the control logic board CL5001 which is placed over the main section of the synthesizer board.

The Frequency Synthesizer board also carries all interconnections between the tone modules and the RF module, and it has two connectors at the rear for accessories and the power supply cable.

SUPPLY VOLTAGE DISTRIBUTION SYSTEM

The battery voltage (A + BATT) enters the radio via two pins of the rear system connector to the synthesizer board. Both inputs are connected to reverse polarity protection diodes D741, D742. The ground lead comes through the same connector and is connected to chassis ground through a fusible printed wiring path which will open in case of the ground wire being accidentally connected to A +.

One battery input goes directly from the synthesizer board via a feed-through capacitor and a connector P907 to the transmitter PA stages. The other input feeds through P903 - J903 to the RF board for two functions. One branch for the audio amplifier passes through an RC-ripple filter R638 - C618 and one of the ON/OFF switch sections S602. The other section of the ON/OFF switch controls the $V_B +$ to the voltage regulator U602 consisting of a monolithic regulator. The regulator output is fixed at 8.5 V by means of a factory adjusted resistor.

Regulated 8.5 V is switched to either the receiver or the transmitter by the antenna relay. The antenna relay is also supplied by the 8.5 V regulated.

The squelch circuit, the modulation processor, parts of the IF amplifier U502, and the Frequency Synthesizer is supplied directly from the continuous 8.5 V.

The receiver front-end, the 10.7 MHz IF stages and the second oscillator are supplied from 8.5 V RX. The transmitter exciter is supplied from 8.5 V TX.

In sets with 5-tone sequential option or Pilot tone, the PTT (Push to talk) lead runs through

the option board to provide for correct tone keying function.

WARNING

The transmitter PA transistors contain Beryllia which is poisonous when absorbed by the human body. Dissection, filing, or grinding of these transistor may be hazardous.

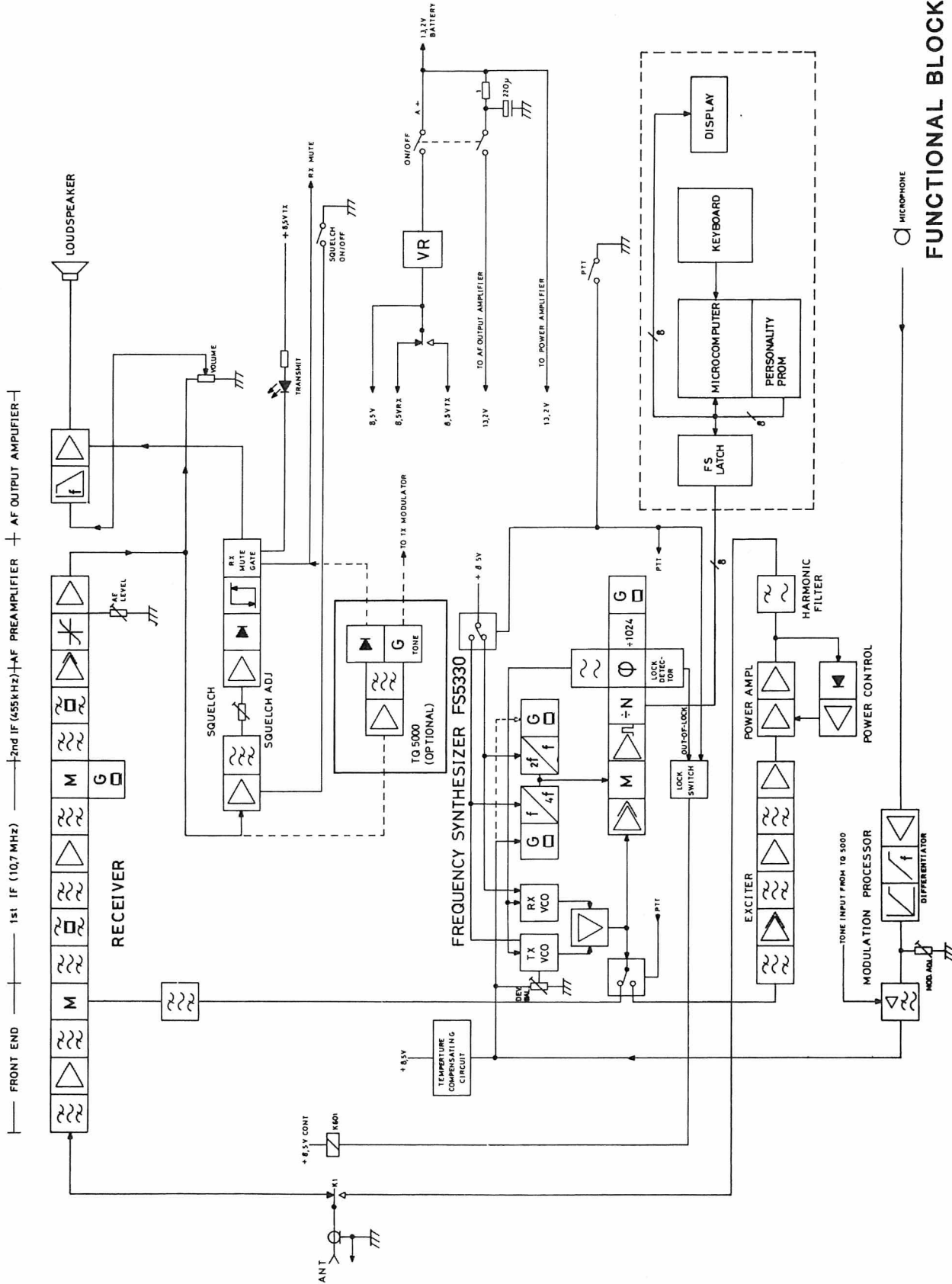

FUNCTIONAL BLOCK DIAGRAM
CQM5330 S99
D403.180

CHANNEL PROGRAMMING INSTRUCTIONS

CQM5330 S99

Programming of the PROM which contains the personality data will normally be part of the factory process, but it may also be field programmed.

The PROM programming unit must be approved by the PROM manufacturer, as for example (DATA I/O SYSTEM 19).

The programmer consists of the following items:

Programmer (DATA I/O SYSTEM 19)

Programming Pak, interchangeable

Socket adaptor

or universal programming pack.

DATA I/O UNIPAK (adaptable for more than 200 types of PROM devices).

To program a PROM the channel frequencies for all allocated channels and the channel spacing must be known.

It is recommended to complete a worksheet when calculating the prom data.

It is also possible to use a computer to calculate the prom data and Storno will be able to supply software programs for certain types of computers.

Operating instructions for the Programmer is supplied by the vendor.

WORKSHEET

For each PROM to be programmed a worksheet should be completed to calculate the input data for each channel.

The procedure for completing the worksheet is:

1. Complete list of receiver channel frequencies. (A).
2. Complete list of transmitter channel frequencies. (B).
3. Find highest (H) and lowest (L) receiving frequencies.
4. Find highest (H) and lowest (L) transmitting frequencies.
5. Select receiver mixer crystal frequency (C) from table 1. The highest and lowest receiver frequencies must be within the selected band.
6. Select transmitter mixer crystal frequency (D) from table 2. The highest and lowest transmitter frequencies must be within the selected band.
7. Note channel spacing and Reference frequency (F). See worksheet.
8. Use receiver formula to calculate " V_{DEC} " (divisor) for all receiver channels.
9. Use transmitter formula to calculate " V_{DEC} " (divisor) for all transmitter channels.
10. Check " V_{DEC} " for all channels to be between 256 and 511.
11. Use receiver crystal frequency and V_{DEC} to check for selfquieting frequencies, table 3.
12. In case of selfquieting select appropriate alternative and possibly recalculate "V".
13. Convert all " V_{DEC} " numbers to hexadecimal code. Refer to tabel 4.
14. Assign the hexadecimal codes to the corresponding channels and the PROM addresses.

After completing the worksheet enter correct Prom addresses and corresponding data (V_{HEX}) on the Programmer (DATA I/O), refer to Programmer Operating Instructions.

RECOMMENDED CRYSTAL FREQUENCIES

CQM5330 S99

CQM5332 - CQM5334 FREQUENCY RANGE	CQM5333 FREQUENCY RANGE	RX CRYSTAL
65.2 - 68.3875	64.56 - 67.11	36.35
66.2 - 69.3875	65.56 - 68.11	36.85
67.2 - 70.3875	66.56 - 69.11	37.35
68.2 - 71.3875	67.56 - 70.11	37.85
69.2 - 72.3875	68.56 - 71.11	38.35
70.2 - 73.3875	69.56 - 72.11	38.85
71.2 - 74.3875	70.56 - 73.11	39.35
72.2 - 75.3875	71.56 - 74.11	39.85
73.2 - 76.3875	72.56 - 75.11	40.35
74.2 - 77.3875	73.56 - 76.11	40.85
75.2 - 78.3875	74.56 - 77.11	41.35
76.2 - 79.3875	75.56 - 78.11	41.85
77.2 - 80.3875	76.56 - 79.11	42.35
78.2 - 81.3875	77.56 - 80.11	42.85
79.2 - 82.3875	78.56 - 81.11	43.35
80.2 - 83.3875	79.56 - 82.11	43.85
81.2 - 84.3875	80.56 - 83.11	44.35
82.2 - 85.3875	81.56 - 84.11	44.85
83.2 - 86.3875	82.56 - 85.11	45.35
84.2 - 87.3875	83.56 - 86.11	45.85
85.2 - 88.3875	84.56 - 87.11	46.35
86.2 - 89.3875	85.56 - 88.11	46.85
87.2 - 90.3875	86.56 - 89.11	47.35
88.2 - 91.3875	87.56 - 90.11	47.85

TABLE 1. RECEIVER MIXER CRYSTAL FREQUENCY

RECOMMENDED CRYSTAL FREQUENCIES

CQM5330 S99

CQM5332 - CQM5334 FREQUENCY RANGE	CQM5333 FREQUENCY RANGE	TX CRYSTAL
65.2 - 68.3875	64.56 - 67.11	15.5
66.2 - 69.3875	65.56 - 68.11	15.75
67.2 - 70.3875	66.56 - 69.11	16.
68.2 - 71.3875	67.56 - 70.11	16.25
69.2 - 72.3875	68.56 - 71.11	16.5
70.2 - 73.3875	69.56 - 72.11	16.75
71.2 - 74.3875	70.56 - 73.11	17.
72.2 - 75.3875	71.56 - 74.11	17.25
73.2 - 76.3875	72.56 - 75.11	17.5
74.2 - 77.3875	73.56 - 76.11	17.75
75.2 - 78.3875	74.56 - 77.11	18.
76.2 - 79.3875	75.56 - 78.11	18.25
77.2 - 80.3875	76.56 - 79.11	18.5
78.2 - 81.3875	77.56 - 80.11	18.75
79.2 - 82.3875	78.56 - 81.11	19.
80.2 - 83.3875	79.56 - 82.11	19.25
81.2 - 84.3875	80.56 - 83.11	19.5
82.2 - 85.3875	81.56 - 84.11	19.75
83.2 - 86.3875	82.56 - 85.11	20.
84.2 - 87.3875	83.56 - 86.11	20.25
85.2 - 88.3875	84.56 - 87.11	20.5
86.2 - 89.3875	85.56 - 88.11	20.75
87.2 - 90.3875	86.56 - 89.11	21.
88.2 - 91.3875	87.56 - 90.11	21.25

TABLE 2. TRANSMITTER MIXER CRYSTAL FREQUENCY

SELFQUIETING FREQUENCIES
CQM5332 S99

RECEIVER CRYSTAL FREQUENCY, MHz	V DEC	USE ALTERNATIVE ⁺
All crystal frequencies	428	1
38.35	457	2
38.85	377	2
39.35	297	2
40.85	464	3
41.35	384	3
41.85	304	3
43.35	474	2
43.85	397	2
44.35	314	2

TABLE 3A. SELFQUIETING FREQUENCIES ⁺refer to worksheet

SELFQUIETING FREQUENCIES
CQM5333 S99

RECEIVER CRYSTAL FREQUENCY, MHz	V DEC	USE ALTERNATIVE ⁺
38.85	468	3
38.85	471	2
39.35	368	3
39.35	371	2
39.85	268	3
39.85	271	2
43.85	492	3
43.85	496	2
44.35	392	3
44.35	396	2
44.85	292	3
44.85	296	2

TABLE 3B. SELFQUIETING FREQUENCIES ⁺refer to worksheet

HEX CODE CONVERSION TABLE

		Least Significant Digit (LSD) of Hex Code															
		0	1	2	3	4	5	6	7	8	9	A	B	C	D	E	F
Most Significant Digit of Hex Code.	0	256	257	258	259	260	261	262	263	264	265	266	267	268	269	270	271
	1	272	273	274	275	276	277	278	279	280	281	282	283	284	285	286	287
	2	288	289	290	291	292	293	294	295	296	297	298	299	300	301	302	303
	3	304	305	306	307	308	309	310	311	312	313	314	315	316	317	318	319
	4	320	321	322	323	324	325	326	327	328	329	330	331	332	333	334	335
	5	336	337	338	339	340	341	342	343	344	345	346	347	348	349	350	351
	6	352	353	354	355	356	357	358	359	360	361	362	363	364	365	366	367
	7	368	369	370	371	372	373	374	375	376	377	378	379	380	381	382	383
	8	384	385	386	387	388	389	390	391	392	393	394	395	396	397	398	399
	9	400	401	402	403	404	405	406	407	408	409	410	411	412	413	414	415
	A	416	417	418	419	420	421	422	423	424	425	426	427	428	429	430	431
	B	432	433	434	435	436	437	438	439	440	441	442	443	444	445	446	447
	C	448	449	450	451	452	453	454	455	456	457	458	459	460	461	462	463
	D	464	465	466	467	468	469	470	471	472	473	474	475	476	477	478	479
	E	480	481	482	483	484	485	486	487	488	489	490	491	492	493	494	495
	F	496	497	498	499	500	501	502	503	504	505	506	507	508	509	510	511

"V_{DEC}" Numbers.

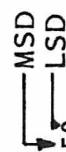

Example "V_{DEC}" = 345 equals to hex code 59.
 "V_{DEC}" = 469 equals to hex code D5.

Table 4.
 "V" Number to hex code conversion table.

PROGRAMMING WORKSHEET

FOR CQM5330 S99

Customer: _____

RECEIVER						TRANSMITTER					
CHAN- NEL	A FREQUENCY MHZ	L H	V DEC	V HEX	PROM ADDRESS (HEX)	B FREQUENCY MHZ	L H	V DEC	V HEX	PROM ADDRESS (HEX)	
1											
2											
3											
4											
5											
6											
7											
8											
9											
10											
11											
12											

RECEIVER MIXER CRYSTAL FREQ. (Y702): C= _____ FORMULA: $V_{DEC} = \frac{(A + 10.7) - (C \times 2)}{F}$	TRANSMITTER MIXER CRYSTAL FREQ. (Y701) D= _____ FORMULA: $V_{DEC} = \frac{B - (D \times 4)}{F}$
---	--

CHANNEL SPACING:	REFERENCE CRYSTAL (Y703):	REFERENCE FREQUENCY:
20 kHz	10.240000 MHz	F= 0.01
12.5/25 kHz	12.800000 MHz	F= 0.0125

LIST OF REFERENCE CRYSTALS (Y703)			
MODE	FREQUENCY, MHz	PART No.	ALTERNATIVE SOLUTIONS IF THE RECEIVER IS SELFQUIETING:
Standard 5332/5334	12.800000	19J06361P1	1. SELECT ANOTHER RX MIXER CRYSTAL FREQUENCY
Offset 5334	12.801000	19J06361P7	2. SELECT HIGH INJECTION FREQUENCY FOR 2nd OSCILLATOR Y501= 11.15500 MHz INSTEAD OF 10.245000 MHz
Offset 5332	12.802000	19J06361P8	3. USE SLIGHTLY OFFSET REFERENCE CRYSTAL
Standard 5113	10.240000	19J06361P2	4. WEAK QUIETING; NO ALTERNATIVE REQUIRED
Offset 5333	10.241300	19J06361P10	

ADJUSTMENT PROCEDURE

CQM5330 S99

This adjustment procedure applies to the following radiotelephone types:

CQM5332 : 30/25 kHz Channel spacing

CQM5333 : 20 kHz Channel spacing

CQM5334 : 12.5 kHz Channel spacing

Before making adjustments to the radiotelephone transmitter/receiver, read the type label and note the channel frequencies.

Check all straps according to the notes on the diagrams. Also check the selective calling tone equipment, if any, against the coding instructions; refer to description of tone equipment.

All screens must be in place and properly secured during the adjustments.

MEASURING INSTRUMENTS

The following list contains instruments necessary for adjusting the radiotelephone and checking its performance characteristics:

DC Voltmeter	$R_{in} \geq 1$ Mohm
AC Voltmeter	$Z_{in} > 1$ Mohm//50 pF
Multimeter	$R_i \geq 20$ Kohm/Volt
Distortion meter	e.g. Storno E11c
RF Watt meter	25 W/50 ohm/66-88 MHz
Deviation meter	66-88 MHz
RF generator	$Z_{out} = 50$ ohm; 66-88 MHz
10.7 MHz signal generator	e.g. Storno TS-G21B

Frequency counter with attenuator	$Z_{in} = 50$ ohm; sensitivity 100 mV at 88 MHz
RF diode probe	Storno 95.0089-00
RF coaxial probe	Storno 95.0179-00
DC power supply	10.8 V - 16.6 V; 6A
Oscilloscope	0 - 5 MHz min.

MISCELLANEOUS

4 ohm/3 W resistor	3 x Storno code 82.5026-00
22 uF/40 V electrolytic capacitor	Storno code 73.5107-00
Connector, 11-pin house	Storno code 41.5543-00
Connector, 8-pin house	Storno code 41.5542-00
Pins for connectors	Storno code 41.5551-00
Trimming tools	

The following tables show the frequency ranges of the CQM5330 S12 radiotelephone signals:

SIGNAL	FREQUENCY MHz
TX VCO	66 - 88
TX crystal	15 - 21
TX crystal multiplication	x4
RX VCO	77 - 99
RX crystal	38 - 49
RX crystal multiplication	x2

Table 1.

Channel spacing kHz	Reference Crystal MHz	Min. Divider input frequency MHz	Max. Divider input frequency MHz	Reference frequency kHz
20	10.240	2.560	5.110	10
12.5 or 25 ¹⁾	12.800	3.200	6.3875	12.5
15.0 or 30 ¹⁾	15.360	3.840	7.665	15

Table 2 ¹⁾ Two steps per channel

RECEIVER TEST SET-UP

CQM5330 S99

D402.882/2

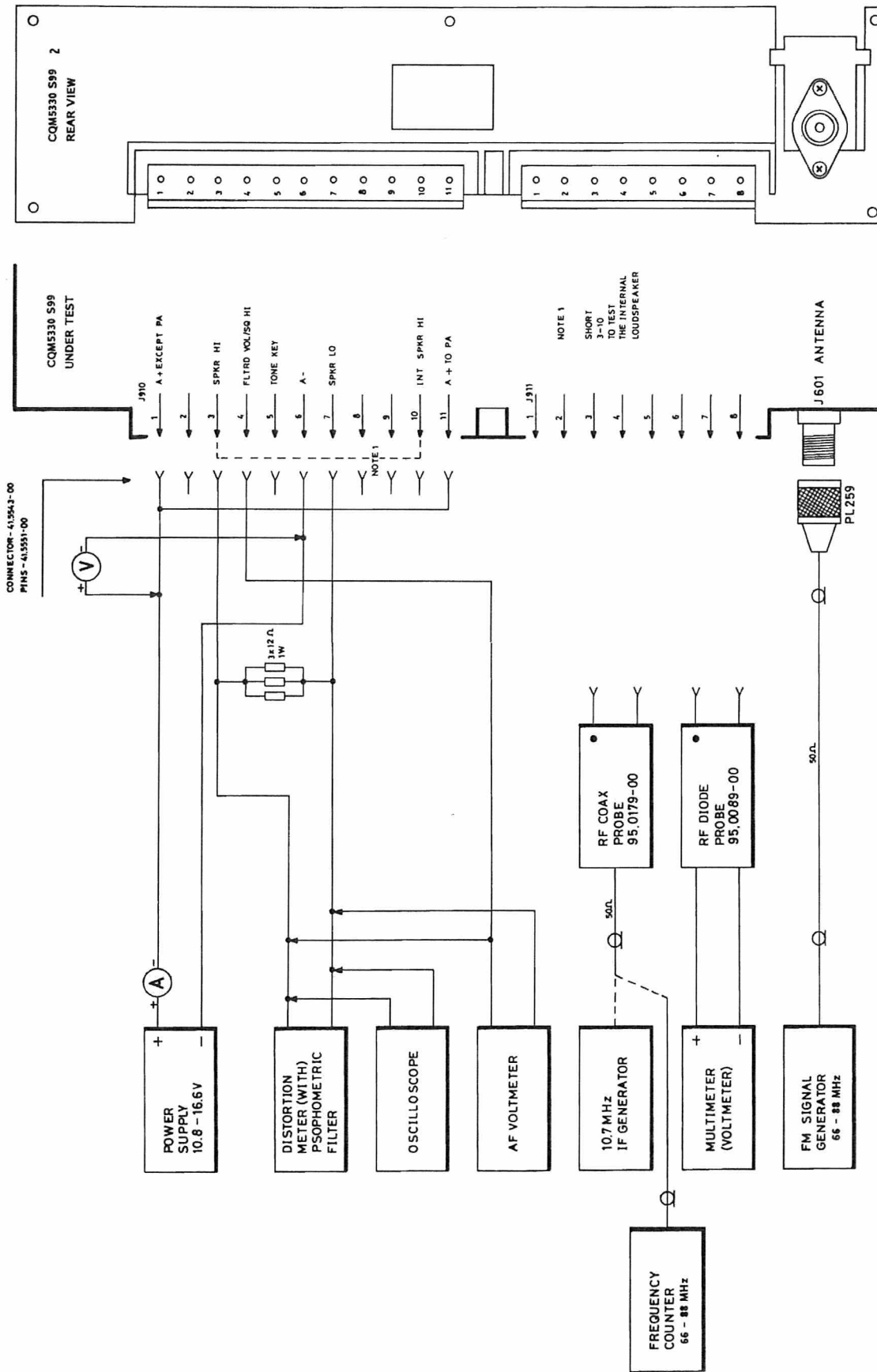

RECEIVER ADJUSTMENT

CHECKING 8.5 V REGULATED SUPPLY

Turn the power supply ON and set the voltage to 13.2 V. Set the power supply current limiter to 1 A.

Turn the radiotelephone ON by depressing the ON/OFF button. Note the light in the Channel selector, if any, is on.

Depress the Squelch button.

Set the volume control to minimum.

Connect the DC voltmeter to J901 pin 3 and read the Voltage.

Requirement: $8.5\text{ V} \pm 0.15\text{ V}$

If the requirement is not fulfilled check resistor R636 against the colour code of U602.

U602 colour code R636 Value

Brown	omit
Red	270
Orange	100
Yellow	47
Green	22
Blue	6.8

Adjust the power supply voltage to 16.6 V and read the 8.5 V regulated. Compare the change in the 8.5 Volt regulated to the value obtained at 13.2 V.

Requirement: $\leq 50\text{ mV}$

Repeat the procedure with the power supply adjusted for 10.8 V

FREQUENCY SYNTHESIZER ALIGNMENT

Check the PROM U801, the TX mixer crystal, the RX mixer crystal, and the reference crystal and verify the frequencies and prom codes.

Mixer crystal output

Connect RF diode probe 95.0089-00 with multimeter to test point TP701. (1 V range).

Adjust L711 for maximum deflection on the multimeter.

Adjust L707 for maximum deflection on the multimeter.

Requirement: $250\text{ mV} \pm 125\text{ mV}$
(corresponding to -10 dBm to -4 dBm).

Note: Be careful not to resonate L707 to the false harmonics. If in doubt consult table 1 or check the crystal oscillator output with a spectrum analyzer.

Receiver VCO

Connect the multimeter, 10 V range, to test point TP706. The synthesizer's lock signal is accessible at TP706. +8 V DC with very narrow pulses (0.1 μ sec) indicates normal locked condition. Unlocked condition is indicated by a variable duty signal or logic "Low". Select the channel whose frequency is closest to the center frequency.

Await locked condition, constant voltage.

Adjust C745 for 8 Volts on the multimeter.

Connect the multimeter to test point TP703.

Adjust C745 for a voltage corresponding to the variable divider ratio (V) as indicated by the graph fig. 1.

Requirement: The voltage shall be in the range 1.5 V to 6.5 V and not deviate from the graph by more than 20%.

Mixer Crystal Frequency

Connect coax probe 95.0179-00 to test point TP701.

Connect the frequency counter to the probe and read the frequency.

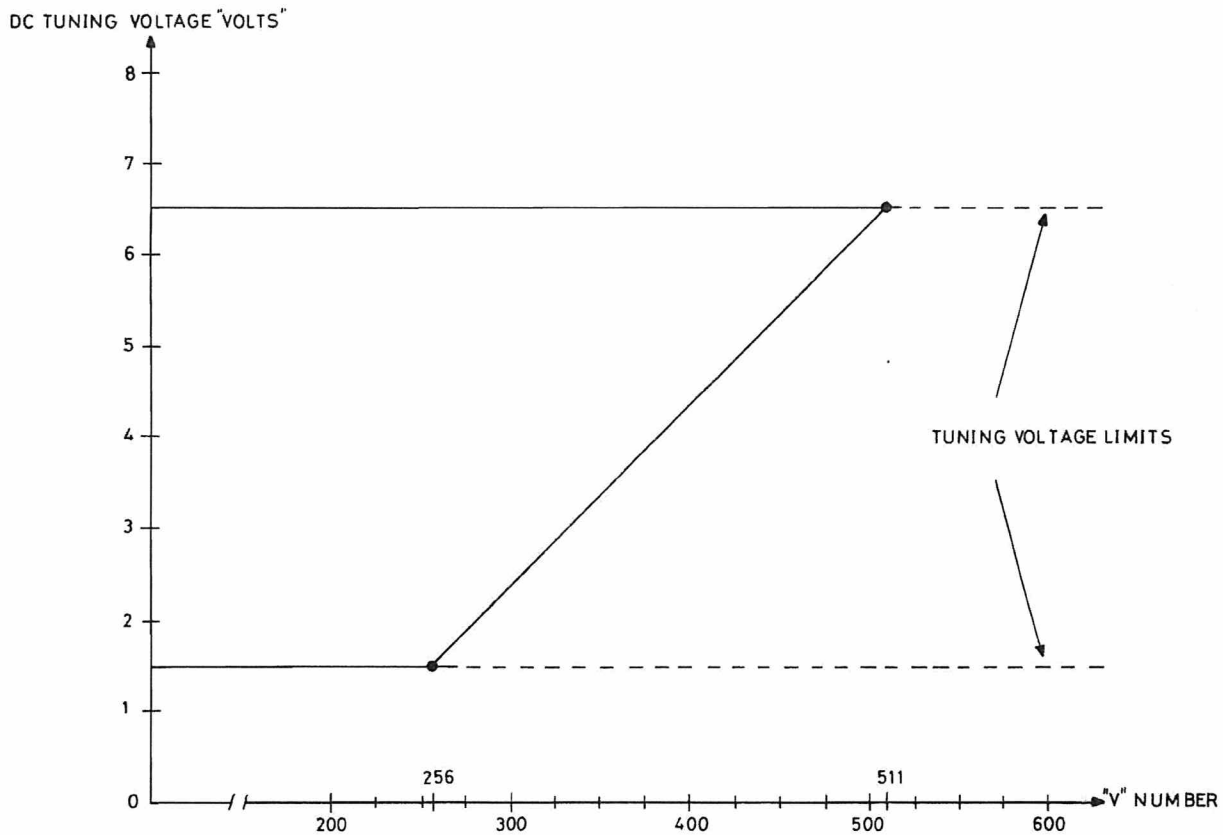

Fig. 1. Tuning voltage vs. V. number.

$f = f_x \times 2$ (f_x = crystal frequency)
 Adjust L711 to the calculated frequency.
 Requirement: $f \pm 0.3$ ppm at 25°C .
 ppm = parts per million = 10^{-6}

Injection Frequency

Connect coax probe 95.0179-00 to test point TP401.
 Connect the frequency counter to the probe.
 Calculate the injection frequency for all channels.

$$f_{inj} = f_{ant} + 10.7 \text{ (MHz)}$$

Select, one by one, the channels and read the injection frequency.

Requirement: $F_{inj} \pm 0.4$ ppm

IF AMPLIFIERS

Connect a 10.7 MHz signal generator to TP401 via coax probe 95.0179-00.

Connect RF diode probe 95.0089-00 with multimeter to test point TP501. (50 μA range). During adjustment the RF generator output must be kept low enough to prevent limiting in the IF stages, i. e. a maximum reading of 50 μA on the multimeter.

Adjust coils L503, L502, L501, and L406; in that order, for maximum deflection on the multimeter.

FRONT-END

Connect the RF probe 95.0089-00 and the multimeter to test point TP501. (50 μA range). Connect an unmodulated RF generator to the antenna connector, J601.

Set the generator frequency to the receiver frequency.

Adjust the generator output to produce a deflection on the multimeter, i. e. a maximum reading of 50 μA on the multimeter.

Adjust L401 and L402 for maximum deflection.
Detune L403 and 405 as much as possible.

Adjust L404 for maximum deflection on the multimeter. This is the only adjustment of L404 and it must not be touched during the rest of the procedure.

Adjust L403 and L405 for maximum deflection on the multimeter.

Readjust L401 and L402 for maximum deflection.

Remove the RF diode probe.

Standard Test condition:

Connect the RF generator to antenna connector and adjust the output to 1 mV e. m. f. Modulate the RF generator with 1000 Hz to 60% of Δf max.

CQM5332 S12/S99 ± 3 kHz
CQM5333 S12/S99 ± 2.4 kHz
CQM5334 S12/S99 ± 1.5 kHz

Connect a 4 ohm/3 W resistor load to connector J910/37 (SPKR HI-SPKR LO).
Connect an AF voltmeter to J910/4-7 (FLTD VOL SPKR LO).

IF DEMODULATOR

Turn R521 halfway up.
Adjust L504 for maximum reading on the AF voltmeter.

Connect a distortion meter and AF voltmeter across the 4 ohm resistor. (if Storno E11c distortion meter is used switch the function to AF voltmeter).

Adjust the volume control for approx. 2 V across the load.

Adjust L501 and L406 for minimum distortion. The demodulated signal may be monitored on an oscilloscope connected in parallel with the distortion meter.

Connect the AF voltmeter and distortion meter to J910/4-7 (FLTD VOL - SPKR LO).

Adjust R521 for a reading of 275 mV on the AF voltmeter.

Requirement: 275 mV ± 5 mV.

Read the distortion.

Typical Total Harmonic Distortion (THD) will be less than 5%.

RECEIVER SENSITIVITY

EIA or CEPT method may be used.

Method of measurement CEPT

The purpose of the measurement is to define the ratio of one condition to another.

The first condition is the one where a modulated RF-signal drives the receiver into full limiting. The audio output is measured with the distortion meter (in the CAL position) and, disregarding the amplitude of the audio, this is adjusted to read 100% on the meter scale; this is our reference condition consisting of signal +noise +distortion, where 'signal' is the modulation of the RF, 'noise' is the lowest possible amount achieved from that particular receiver, when receiving a strong carrier, and 'distortion' is the modulation being slightly distorted in passing through the receiver.

The second condition is the one where the signal (modulation) is removed with a notch filter and the RF-signal is lowered in amplitude until the remaining noise and distortion increases to 20 dB below the first condition, as read on the distortion meter scale. This corresponds to a reading of 10%, 10 being 20 dB below 100, which was our reference condition.

In practice our first condition is achieved by feeding a minimum of 1000 uV of RF-signal modulated with 1000 Hz at 60% Δf max. to the receiver.

The audio output (which must be at least 100% of the receiver's audio rating) is mea-

sured through the psophometric filter, with the distortion meter in position CAL and adjusted with potentiometer ADJ. FSD. to a reading of 100.

The notch filter is then inserted in series with the audio by pressing one of the buttons marked in %. The meter needle immediately drops to indicate a low value, this being the receiver's inherent audio distortion.

By backing off the attenuator of the RF-generator thereby lowering the RF input to the receiver, the noise will eventually increase; the attenuator is now adjusted for a 10% reading on the distortion meter scale.

At this stage it must be ensured that the increased noise and the signal (with the notch filter switched out while checking) still equals 100 on the meter scale.

The RF-generator's calibrated attenuator now shows the value of RF-signal required to achieve a 20 dB ratio between signal + noise + distortion and noise + distortion, i. e. 20 dB SINAD sensitivity.

EIA Method

EIA (Electronic Industrie's Association) Standard, definition:

The SINAD sensitivity of a receiver is the minimum input signal that will provide at least 50% of the receivers's rated audio power with 12 dB signal + noise + distortion to noise + distortion.

The EIA method differs from CEPT by omitting the psophometric filter, adjusting the RF generator for $2/3 \times \Delta f_{max.}$, and measure the distortion at 50% of the receiver's rated AF power. The SINAD sensitivity is measured as a 12 dB ratio between signal + noise + distortion and noise + distortion, which corresponds to a reading of 25% noise + distortion.

ADJUSTING THE SENSITIVITY

Lower the RF generator output to obtain 20 dB SINAD (10% THD as measured with the distortion meter). Readjust L402 for the best SINAD value, e. i. lowest generator output for 10% THD.

MEASURING 20 dB SINAD (CEPT)

Adjust the volume control for 2.45 V (1.5 W/4 ohm) as measured with an AF voltmeter across the load.

Adjust the RF generator output to obtain 20 dB SINAD condition.

Read the 20 dB SINAD sensitivity (e. m. f.)

Requirement: $\leq 0.75 \mu V$.

The sensitivity should be measured on all channels, if more than one.

MEASURING 12 dB SINAD (EIA)

Adjust the volume control for 2.45 V as measured with an AF voltmeter across the load.

Adjust the RF generator to obtain 12 dB SINAD condition.

Read the 12 dB SINAD sensitivity.

Requirement: $\leq 0.3 \mu V$ ($\frac{1}{2}$ e. m. f.)

The sensitivity should be measured on all channels, if more than one.

AUDIO FREQUENCY RESPONSE

Set the signal generator to Standard Test Condition.

Adjust the volume control for 0.82 V across the load. (4 ohm across (SPKR HI - LO)).

At 13.2 V supply, $\Delta F = 60\% \Delta F_{max}$ and 1000 Hz measure the output voltage according to the following table:

	Frequency	Level	Tol.
CQM5332 S12/S99	300 Hz	+9 dB	+1 dB/-3 dB
	1000 Hz	0 dB	
	3000 Hz	-9.5 dB	+1 dB/-3 dB
CQM5333 S12/S99	300 Hz	+10.5 dB	+1.5 dB/-3 dB
	400 Hz	+8 dB	+1.5 dB/-1.5 dB
	1000 Hz	0 dB	
	2700 Hz	-8.6 dB	+1.5 dB/-1.5 dB
	3000 Hz	-9.5 dB	+1.5 dB/-3 dB
	6000 Hz	<-20 dB	
CQM5334 S12/S99	300 Hz	+9 dB	+1 dB/-3 dB
	1000 Hz	0 dB	
	2550 Hz	-8 dB	+1 dB/-3 dB

SELF QUIETING CHECK

Internal oscillators, dividers and the harmonic frequencies hereof, may cause self quieting of the receiver if a mixer product falls in the RF or IF pass band.

For proper operation of the squelch all channels must be checked for the self quieting phenomenon.

Connect the RF generator to the antenna connector. Reduce the RF output to 0.

Set the frequency outside the 66 - 88 MHz band.

Alternatively, an attenuator (50 ohm) may be connected to the antenna connector.

Connect an AF voltmeter across the 4 ohm speaker load.

Adjust the volume control for 774 mV (0 dBm) as read on the AF voltmeter.

Select, in turn, all allocated channels.

The reading on the AF voltmeter shall not on any selected channel decline more than 6 dB.

Requirement: Quieting ≤ 6 dB.

AF POWER OUTPUT

Adjust the RF signal generator to Standard Test Condition.

Set the supply voltage to 13.2 V.

Adjust the volume control for 3 W output (3.46 V across the 4 ohm load).

Measure the distortion (THD).

Requirement: THD $\leq 5\%$.

SQUELCH

Release the squelch cancel button.

Adjust potentiometer R607 squelch adj. to open the receiver for an RF input signal corresponding to 8-10 dB SINAD.

The final squelch adjustment must not be set on a channel that has shown a minor degree of selfquieting.

CURRENT CONSUMPTION

Measure the current consumption at 13.2 V.

Requirements

CURRENT CONSUMPTION

CONDITION	S12	S99
Standby	≤ 350 mA	≤ 1000 mA
Receive 2 W AF ~ 2.83 V r. m. s. across 4 ohm.	≤ 750 mA	≤ 1450 mA

For sets with selective calling facilities add current consumption of the tone unit to the figures above.

TRANSMITTER ADJUSTMENT

Adjust the power supply voltage to 13.2 V and set current limiter as follows:

25 W transmitter:	6A
6 W transmitter:	4A

Refer to Receiver Alignment for measuring 8.5 V regulated supply.

Preset all transmitter tuning slugs, L151, L153, L201, L202, L204, and L205 to be flush with the coil form top.

Connect a multimeter (2.5 volt range) to test point TP201.

Turn the power control potentiometer, R221, to minimum, anticlockwise (CCW).

Connect a Wattmeter, (25 W) to the antenna connector, J601.

FREQUENCY SYNTHESIZER ALIGNMENT

Check the PROM U801, the TX mixer crystal, the RX mixer crystal, and the reference crystal and verify the frequencies and the prom codes.

Mixer crystal output

Connect RF probe 95.0089-00 with multimeter to test point TP701 (1 V range).

Key the transmitter.

Adjust L701 for maximum deflection on the multimeter.

Adjust L704 for maximum deflection on the multimeter.

Requirement:

250 mV \pm 125 mV

(corresponding to -10 dBm to -4 dBm)

Note: Be careful not to resonate L704 to the false harmonics. If in doubt consult table 1 or check the crystal oscillator output with a spectrum analyzer.

Transmitter VCO

Connect the multimeter, 10 V range, to test point TP706.

The synthesizer's lock signal is accessible at TP706 and +8 V DC with very narrow pulses (0.1 μ sec.) indicate normal locked condition. Unlocked condition is indicated by a variable duty signal or logic "LOW".

Select the channel whose frequency is closest to the center frequency. Key the transmitter. Await locked condition.

Adjust C737 for 8 Volts on the multimeter.

Connect the voltmeter to test point TP703.

Adjust C737 for a voltage corresponding to the variable divider ratio (V) as indicated by the graph fig. 1.

Requirement: The voltage shall be in the range 1.5 V to 6.5 V and not deviate from the graph by more than 20%.

Mixer Crystal Frequency

Connect coax probe 95.0179-00 to test point TP702.

Connect the frequency counter to the probe, key the transmitter and read the frequency.

$f = f_x \times 4$ (f_x = crystal frequency).

Adjust L701 to the calculated frequency.

Requirement: $f \pm 0.3$ ppm at 25°C.

ppm = parts per million = 10^{-6} .

Synthesizer Output Level

Connect a multimeter, 2.5 V range, to test point TP201. Key the transmitter.

Adjust L153 for maximum deflection on the multimeter, typical more than 0.75 V.

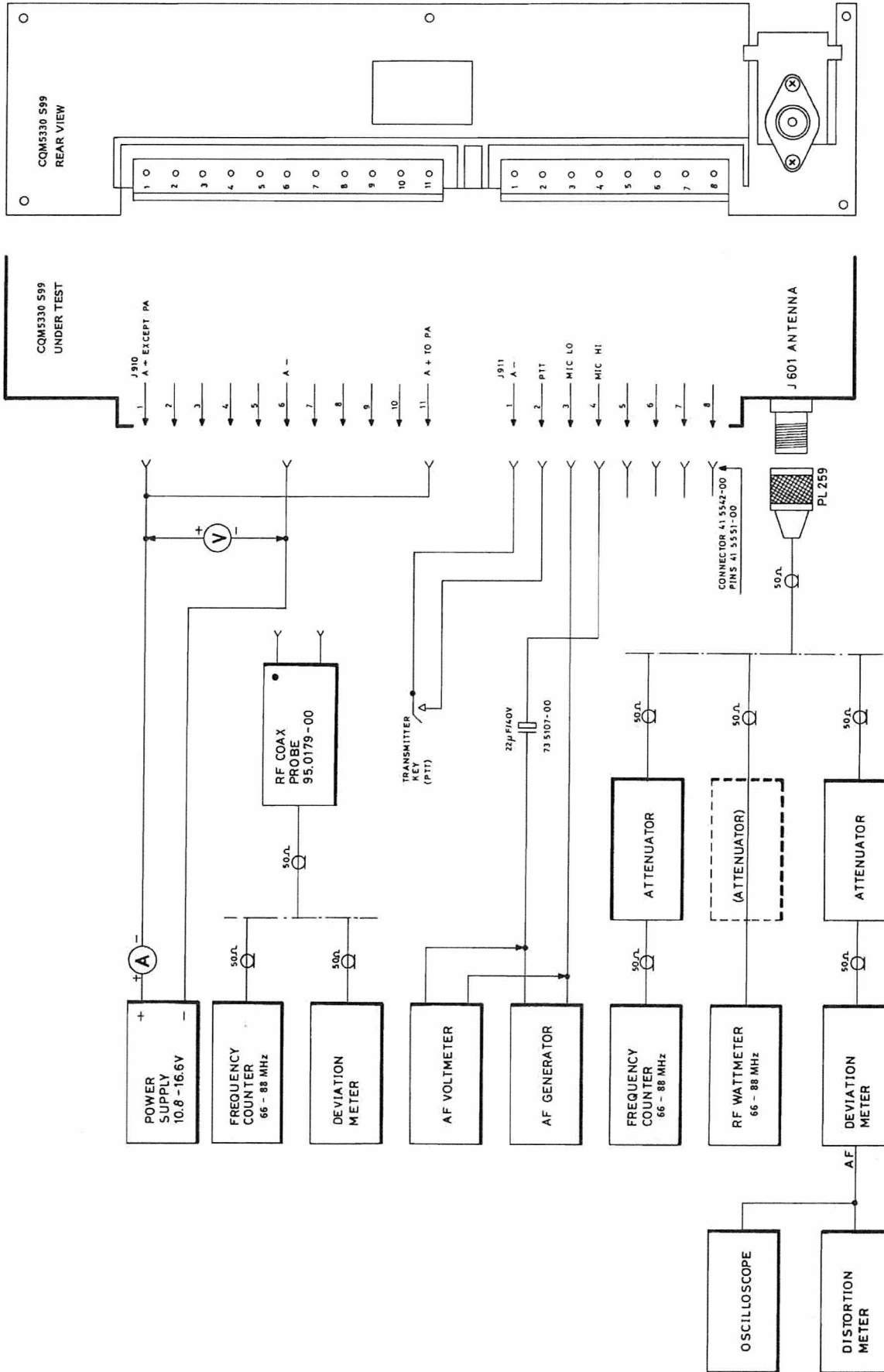

TRANSMITTER TEST SET-UP
 CQM5330 S99

D402.883/2

EXCITER

Coarse adjustment

Connect a multimeter (2.5 V range) to test point TP201. Key the transmitter.

Adjust L153 for maximum deflection.

Adjust L201 for minimum deflection. The dip is small

Connect the multimeter (2.5 V range) to test point TP202.

Adjust L202 for maximum deflection on the multimeter, typical 1.0 V.

Adjust L204 for minimum reading. The dip is small.

Connect diode probe 95.0089-00 and the multimeter (25 V range) to test point TP203.

Adjust L204 and L205 for maximum reading on the multimeter, typical 15 V.

Adjust the PA power control, R221, for rated transmitter power, 6/10 W or 25 W.

Fine adjustment

Connect the multimeter to test point TP201. Key the transmitter.

Readjust L153 for maximum reading.

Connect the multimeter to test point TP202.

Peak L201 and L202 for maximum reading.

If the maximum is not well defined detune L153 slightly, adjust L201 and L202, and repeat the adjustment of L153.

Connect the 95.0089-00 RF probe and multimeter to test point TP203.

Peak L204 and L205 for maximum reading.

TRANSMITTER FREQUENCY ADJUSTMENT

Connect a frequency counter through a suitable attenuator to the antenna connector J601.

Key the transmitter.

Select one by one, the channels and read their frequencies.

Adjust L701 for best frequency tracking on all channels.

Requirement: $F = F_{ant} \pm 0.4 \text{ ppm}$,
ppm = parts per million = 10^{-6}

RF POWER OUTPUT, CURRENT CONSUMPTION, AND POWER CONTROL

Connect the Watt meter to the antenna connector, J601.

Increase the supply voltage to 16 V. The voltage is measured directly at the input connector J910.

Readjust the PA power control, R221, for rated transmitter power (P), 6 (10) or 25 W.

Requirement: $P_{nom} \pm 0.1 \text{ dB}$.

Measure the RF power output at 16 V, 13.2 V and 10.8 V.

Requirements (25 W):

Voltage	Power	S12	S99
		Current	Current
16.6 V	25 W (ref)	$\leq 5.8 \text{ A}$	$\leq 6.5 \text{ A}$
13.2 V	$\geq 23.5 \text{ W}$	$\leq 5.8 \text{ A}$	$\leq 6.5 \text{ A}$
10.8 V	$\geq 20 \text{ W}$	$\leq 5.8 \text{ A}$	$\leq 6.5 \text{ A}$

Requirements (6 W):

Voltage	Power	S12	S99
		Current	Current
16 V	6 W (ref)	$\leq 2.9 \text{ A}$	$\leq 3.6 \text{ A}$
13.2 V	$\geq 5.2 \text{ W}$	$\leq 2.9 \text{ A}$	$\leq 3.6 \text{ A}$
10.8 V	$\geq 5.0 \text{ W}$	$\leq 2.9 \text{ A}$	$\leq 3.6 \text{ A}$

MODULATION ADJUSTMENT

Set the power supply voltage to 13.2 V.

Select the channel having the highest frequency. Set R116 to mid-position.

Connect coax probe 95.0179-00 to test point

TP701.

Connect a deviation meter to the coax probe.

Connect a distortion meter and oscilloscope to the deviation meter output.

Connect a AF generator and an AF Voltmeter to the microphone input via a 22 uF capacitor; refer to test setup.

Set the AF generator to 1000 Hz.

Adjust the AF generator output to 1 V r. m. s.

This voltage is approx. 20 dB above the nominal modulation input level (60% Δf max) to ensure full limiting in the modulation processor.

Note the deviation read at TP701.

Connect the deviation meter to test point TP702.

Adjust R752 (Dev. Bal.) for same deviation as measured at TP701.

Disconnect the deviation meter from the coax-probe and connect it through an attenuator to the antenna connector, J601.

Find the AF frequency between 200 Hz and 3000 Hz giving the greatest frequency deviation as read on the deviation meter with the transmitter keyed.

Check the maximum deviation for both positive and negative deviation polarity. At that audio frequency set the maximum frequency deviation Δf max with R116.

Type	Channel spacing	Δf max
CQM5332	30/25 kHz	±5 kHz
CQM5333	20 kHz	±4 kHz
CQM5334	12.5 kHz	±2.5 kHz

Requirement

Difference between + and - deviation: ≤10%

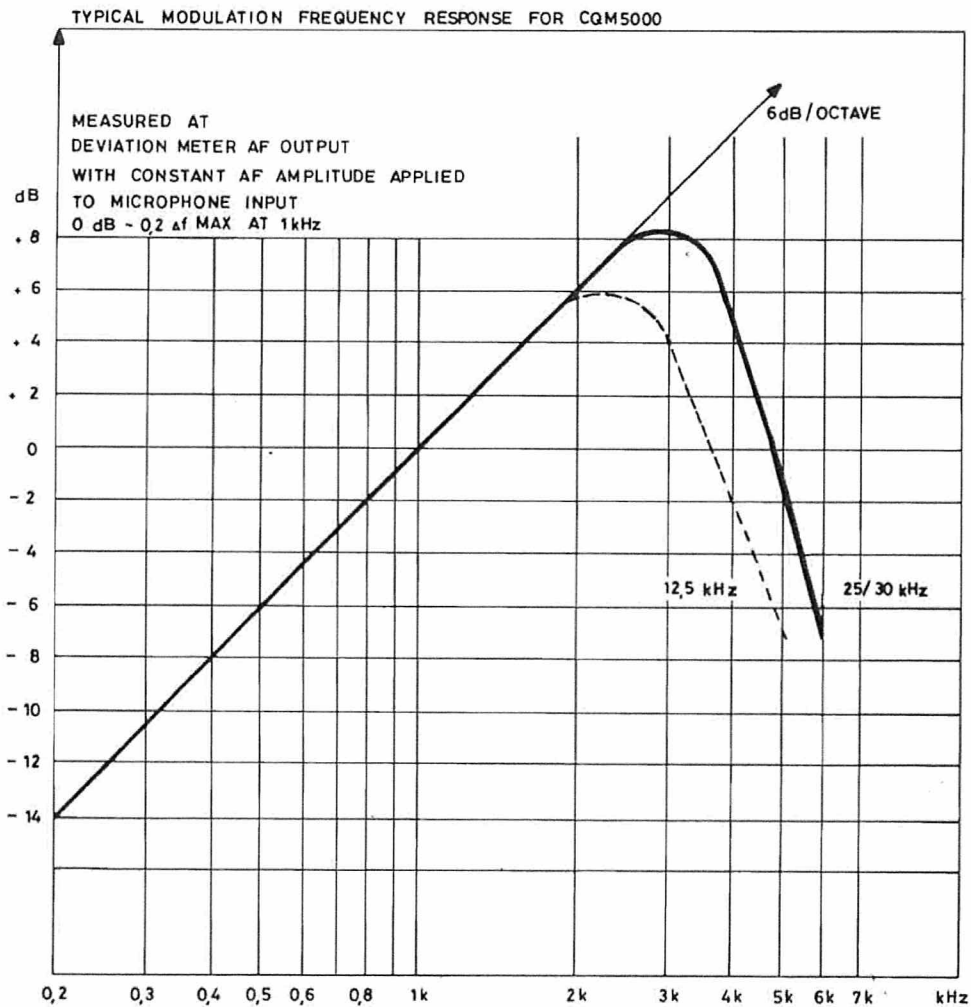

MODULATION SENSITIVITY AND MODULATION DISTORTION

Set the AF generator frequency to 1000 Hz
Adjust the generator output until 60% of Δf max is obtained on the deviation meter.

CQM5332 : ± 3.0 kHz

CQM5333 : ± 2.4 kHz

CQM5334 : ± 1.5 kHz

Read the AF generator output and measure the modulation distortion on the audio output of the deviation meter.

Requirements:

Modulating signal: 75 mV ± 3 dB

Distortion: $\leq 7\%$

(measured without deemphasis)

MODULATION FREQUENCY RESPONSE

Set the AF generator to 1000 Hz.

Reduce the AF generator output until a deviation of $0.2 \times \Delta f$ max is obtained on the deviation meter.

CQM5332 : ± 1.0 kHz

CQM5333 : ± 0.8 kHz

CQM5334 : ± 0.5 kHz

Vary the frequency of the generator and note the deviation changes as referred to the 1000 Hz value.

Requirement :

Within the frequency range 400–2700 Hz the frequency characteristic shall lie within +1 dB/-1.5 dB related to a 6 dB/octave characteristic.

With 6 kHz modulation frequency the deviation shall be attenuated at least 6 dB below the 1 kHz value.

CHANNEL FREQUENCY SYNTHESIZER

FS5331 and FS5332

The frequency synthesizer generates up to 12 channel frequencies for a STORNOPHONE 5000 operating in the 66 - 88 MHz band. It is built on a printed circuit board which mounts in the top section of the radio set. There are two versions of the board, a single channel board, FS5331 and a multichannel board FS5332. The frequency of the single channel board is set by putting a binary code directly on the programmable divider input while the multichannel board channels are selected with a channel selector and a Frequency Control unit, FC5001. The channel selector is mounted directly on the board and protrudes through the front panel, and the Frequency Control module FC5001, fits into the cast shield which is placed over the main section of the synthesizer board. A metal shield is placed underneath the oscillator and mixer sections of the board.

All circuitry can be accessed and operated for repair and maintenance without the shields and with the FC5001 in its socket.

The Frequency Synthesizer board also carries all interconnections between the tone modules and the RF module and has two connectors at the rear for accessories and power supply cables.

The channel programming is contained in a 256 bit PROM placed in a socket on the Frequency Control module. The PROM can be field programmed if the necessary programming equipment is available. Programming equipment and procedures must be approved by STORNO and the PROM manufacturer, refer to the Channeling Instruction.

CIRCUIT DESCRIPTION

The Frequency Synthesizer generates the local oscillator injection for the receiver and a modulated exciter signal for the transmitter. The circuit is a single-loop phase-locked frequency generator.

The synthesizer frequency is controlled by three crystals, one reference crystal and two mixer crystals, and by a PROM. The synthesizer can be reprogrammed for new frequencies if these are within the maximum frequency spread of the STORNOPHONE 5000.

Two voltage controlled oscillators (VCO) are generating the signals which are used as injection for the receiver mixer and excitation signal for the transmitter. The frequency of each VCO can be preset to any frequency

within the band by a variable capacitor, and the fine adjustment is controlled by a variable capacitance diode, varicap, and the phase detector output. The control voltage for the varicaps is filtered in a loop integrating filter. The TX VCO has an additional varicap which is used to modulate the transmitter.

The Push-to-talk switch controls a transistor switch, which switches the supply voltage between the RX VCO and the TX VCO.

The output signal from the VCO's are fed into a buffer amplifier which protects the VCO from load changes.

The buffer amplifier's output is applied to an isolation amplifier and a diode switch before entering the RF board.

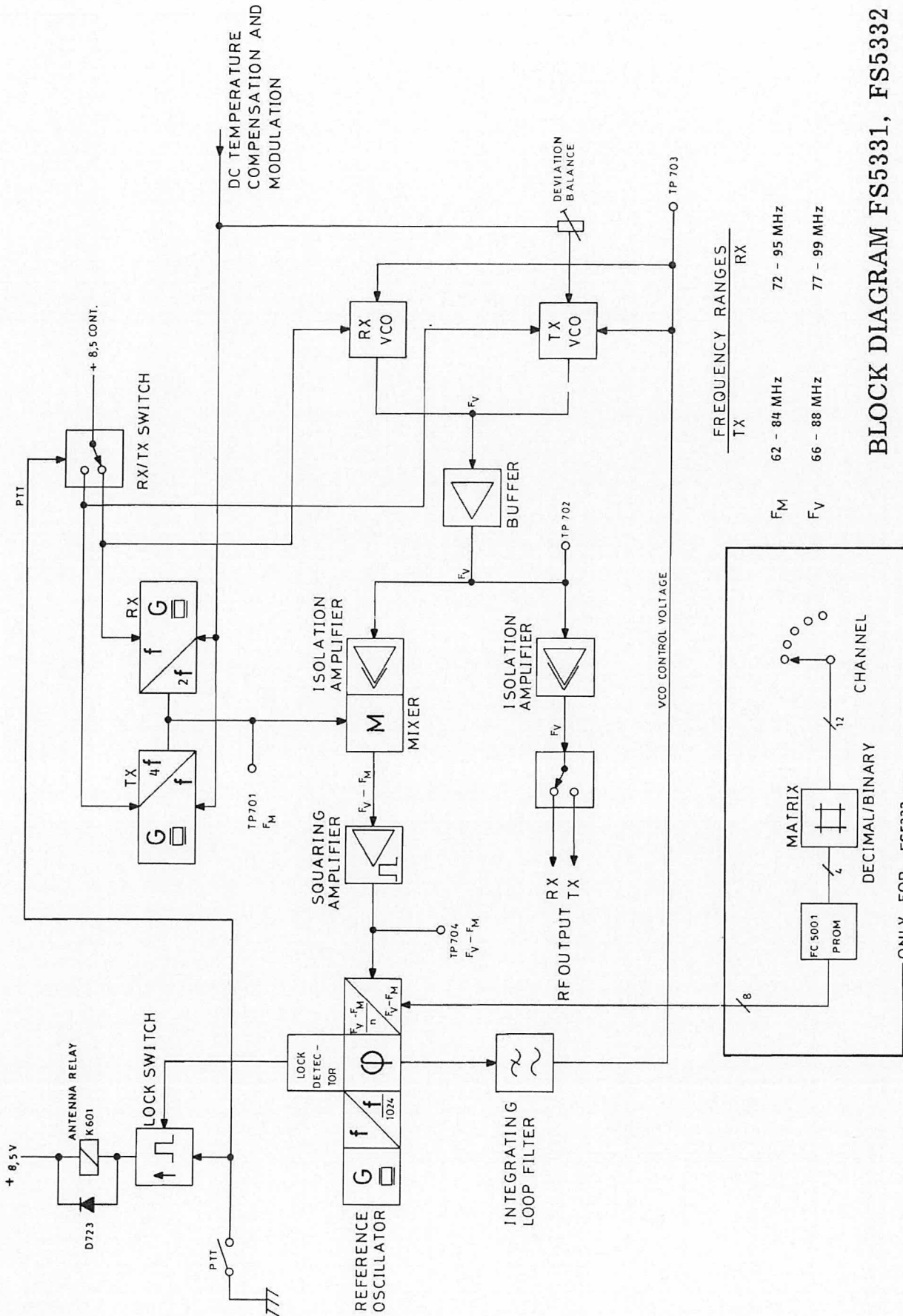

FREQUENCY RANGES	
TX	RX
F_M	62 - 84 MHz
F_V	66 - 88 MHz
	72 - 95 MHz
	77 - 99 MHz

BLOCK DIAGRAM FS5331, FS5332

D402.878

ONLY FOR FS5332

The buffer amplifier also connects to another isolation amplifier via a resistive attenuator and feeds the signal to the synthesizer mixer.

The synthesizer mixer mixes the VCO signal and the crystal oscillator signal to a frequency which is within the dividing capability of the programmable divider.

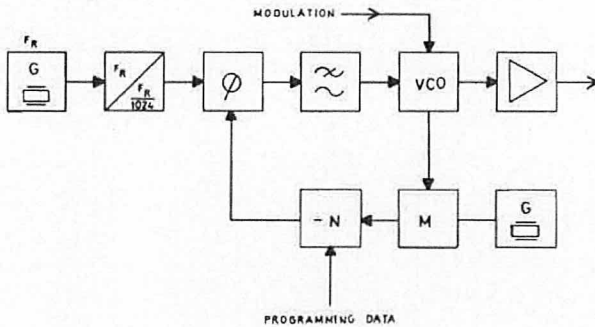

Fig. 2 Phase Locked loop Principle

A temperature compensating voltage is applied to the crystal oscillators only in the 5 p.p.m. version. This voltage is kept constant in the 10 p.p.m. version by cutting a diode on the RF board.

The output from the synthesizer mixer is fed to a squaring amplifier which drives the programmable divider and this divides the frequency by 256 to 511 depending on the logic levels on the 8-bit binary control input. The input frequency range for the divider differs according to the channel spacing and is shown in fig. 3.

The phase detector produces a waveform with variable duty cycle which depends on the phase and frequency difference between its two input signals. The operating frequency range of the phase detector is 4 kHz to 15 kHz and it depends on the channel spacing.

Separate crystal oscillators are used in the receive and transmit mode, respectively, and they are both third mode oscillators.

The reference frequency is generated in a crystal oscillator whose output is divided by 1024 and applied to the phase detector.

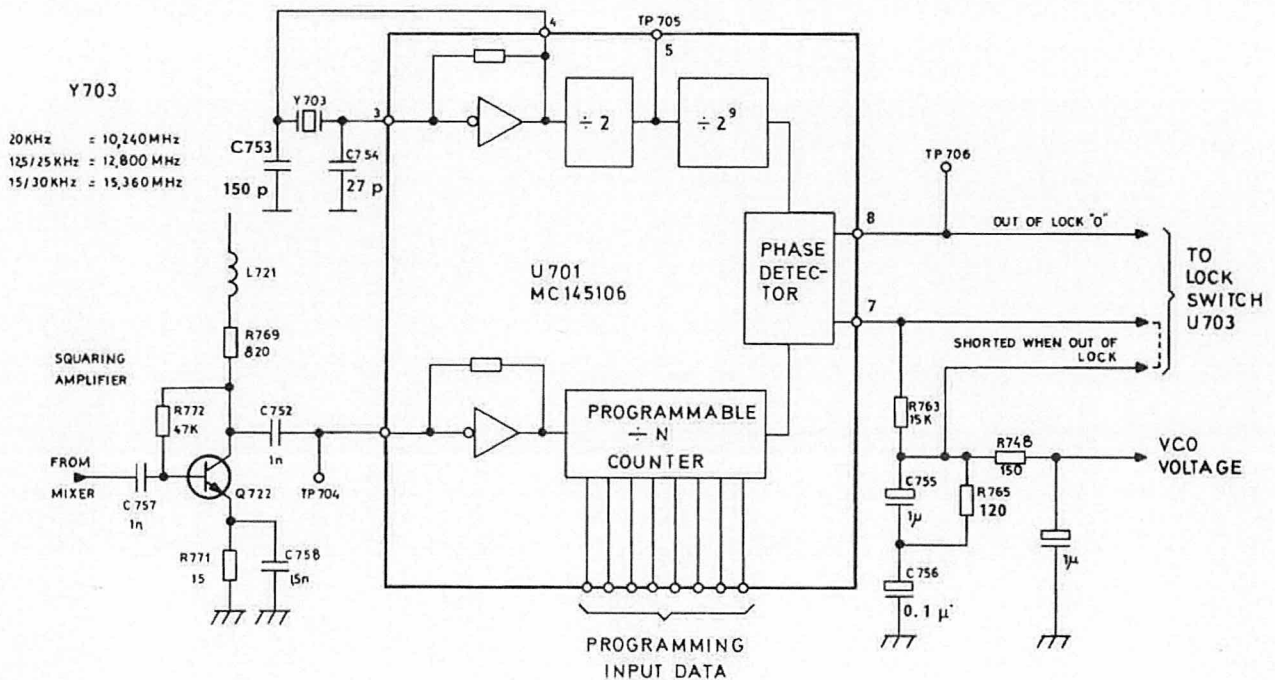

Fig. 3. REFERENCE OSCILLATOR, DIVIDER, AND PHASE DETECTOR

The output from the phase detector passes through a passive integrating filter which produces a DC voltage proportional to the duty cycle of the phase detector output. This voltage adjusts the frequency of the VCO.

An out-of-lock circuit inhibits the transmitter when the synthesizer loop is out of lock and hunting for the frequency.

The transmitter modulation is applied simultaneously to the transmitter mixer-oscillator and the VCO. The modulation bandwidth also covers sub-audio frequencies used for channel guard (pilot tones). The frequency deviation balance adjustment equalizes the deviation on both oscillators to ascertain low distortion and low noise reference side bands during modulation of the synthesizer because it is operating with a relatively large loop bandwidth.

The frequency control module, FC5001, is built on a separate wiring board which mount on top of the synthesizer shield. This module converts the BCD-code (4 bits) from the channel selector to an 8-bit binary code for the programmable divides in the synthesizer loop. These 8-bit codes are programmed into a PROM (Programmable Read Only Memory) and are dividing factors expressed in hexadecimal codes.

On the FC5001 is a 5-Volt regulator which supply the voltage for the PROM. When the PTT button is pushed the transistor Q801 converts the PTT voltage level to TTL level and puts a logic "0" on the MSB (Most Significant Bit) on the address input of the PROM. This selects the PROM code for the corresponding transmitter channel. The PROM outputs have open collectors with external pull-up resistors.

TECHNICAL SPECIFICATION

Supply Voltage

+8.5 Volts regulated
+13.2 Volts unregulated

Current Consumption

max. 80 mA (+8.5 V)
max. 200 mA (+13.2 V)

Channel Spacing

20 kHz
12.5/25 kHz
15/30 kHz

Modulation Input

0.75 V r.m.s. ± 2 dB
 $\Delta f = 60\% f_{\text{mod}} = 1$ kHz

Modulation Bandwidth

70 - 3000 Hz

Modulation Distortion

70 - 300 Hz: $< 5\%$
1 kHz: $< 4\%$

DC Temperature Stabilization Voltage

$25^{\circ}\text{C} = 6 \text{ V} \pm 10\%$ (reference)
 $-30^{\circ}\text{C} = +350 \text{ mV} \pm 10\%$
 $-10^{\circ}\text{C} = -50 \text{ mV} \pm 10\%$
 $+60^{\circ}\text{C} = +50 \text{ mV} \pm 10\%$

The voltage characteristic is approximately linear between these points.

RF Output Level

4 mW ± 1 mW
(open collector output connected to tuned circuit)

TX Output Frequency Range

66 - 88 MHz (VCO)

RX Output Frequency Range

77 - 99 MHz (VCO)

Frequency Stability

5 p.p.m. or 10 p.p.m.

Reference Crystal Frequency

20 kHz: 10.240 MHz

12.5/25 kHz: 12.800 MHz

Signal-to-Noise Ratio (S/N)

>100 dB

 $\Delta f = 25$ kHz, BW (Bandwidth) = 10 kHzSpurious Attenuation

>85 dB

Lock Time

<30 m sec.

for 1 MHz step

Logic Control Level

LOW= <2 V

HIGH= >6 V

8 bit binary positive logic with built-in pull down resistors, $I_{in} = 175$ uA per bit.Temperature range -30°C to $+60^{\circ}\text{C}$ Dimensions

135 x 190 x 45 mm (BxDxH)

Weight

PC board: 150 g

Shield: 75 g

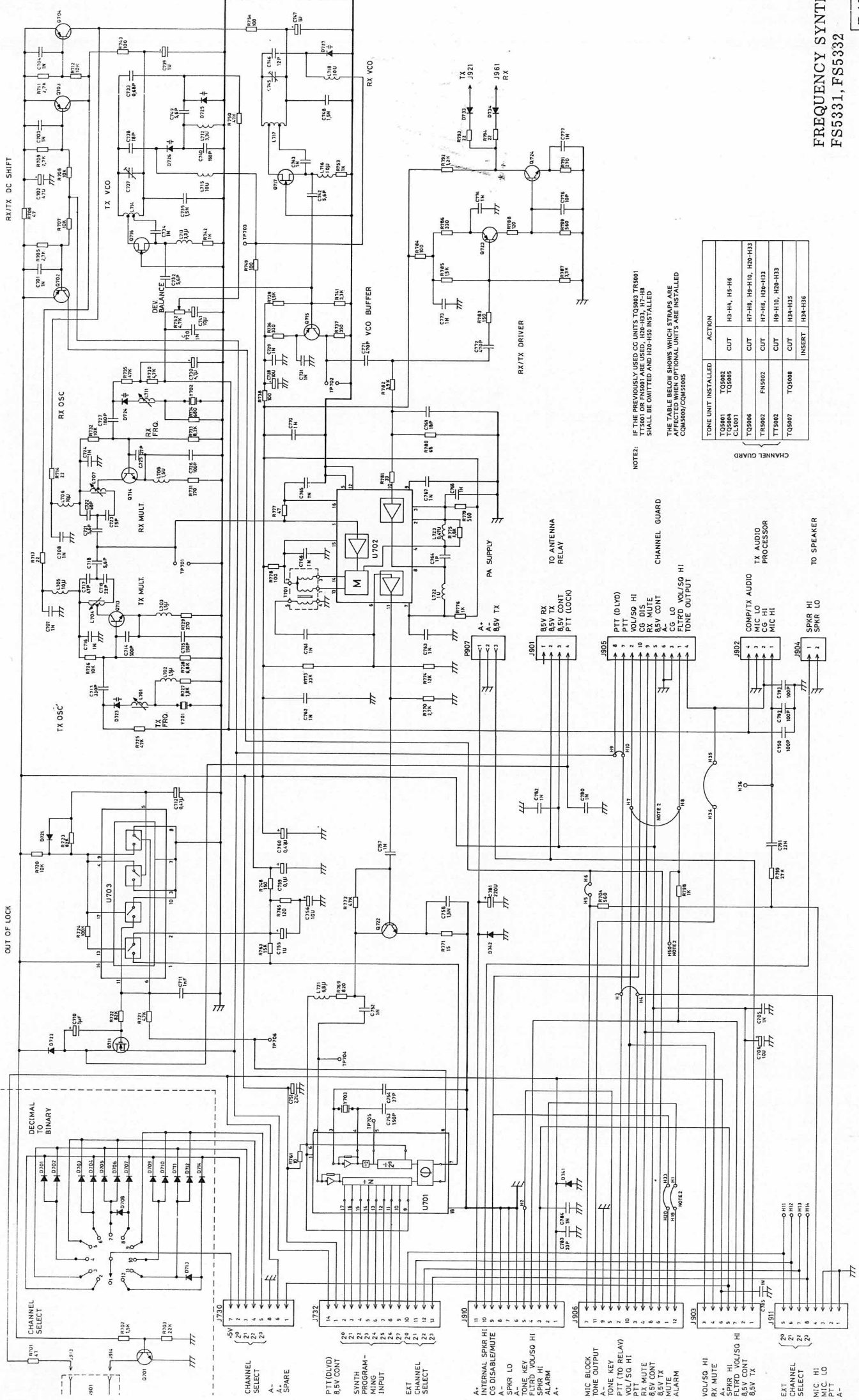

NOTES:
 IF THE PREVIOUSLY USED CG UNITS TQ5003 TO TQ5001
 TT5001 OR FN5001 ARE USED, H20-H13, H7-H8
 SHALL BE OMITTED AND H20-H10 INSTALLED

THE TABLE BELOW SHOWS WHICH STRAPS ARE
 COMPARISON/COMPARISON
 CHANNEL GUARD

TO NE UNIT INSTALLED	ACTION
TQ5001	CUT
TQ5002	CUT
TQ5003	CUT
TQ5004	CUT
TQ5005	CUT
TQ5006	CUT
TQ5007	CUT
TQ5008	INSERT
TQ5009	INSERT
TQ5010	INSERT
TQ5011	INSERT
TQ5012	INSERT
TQ5013	INSERT
TQ5014	INSERT
TQ5015	INSERT
TQ5016	INSERT
TQ5017	INSERT
TQ5018	INSERT
TQ5019	INSERT
TQ5020	INSERT
TQ5021	INSERT
TQ5022	INSERT
TQ5023	INSERT
TQ5024	INSERT
TQ5025	INSERT
TQ5026	INSERT
TQ5027	INSERT
TQ5028	INSERT
TQ5029	INSERT
TQ5030	INSERT
TQ5031	INSERT
TQ5032	INSERT
TQ5033	INSERT
TQ5034	INSERT
TQ5035	INSERT
TQ5036	INSERT
TQ5037	INSERT
TQ5038	INSERT
TQ5039	INSERT
TQ5040	INSERT
TQ5041	INSERT
TQ5042	INSERT
TQ5043	INSERT
TQ5044	INSERT
TQ5045	INSERT
TQ5046	INSERT
TQ5047	INSERT
TQ5048	INSERT
TQ5049	INSERT
TQ5050	INSERT

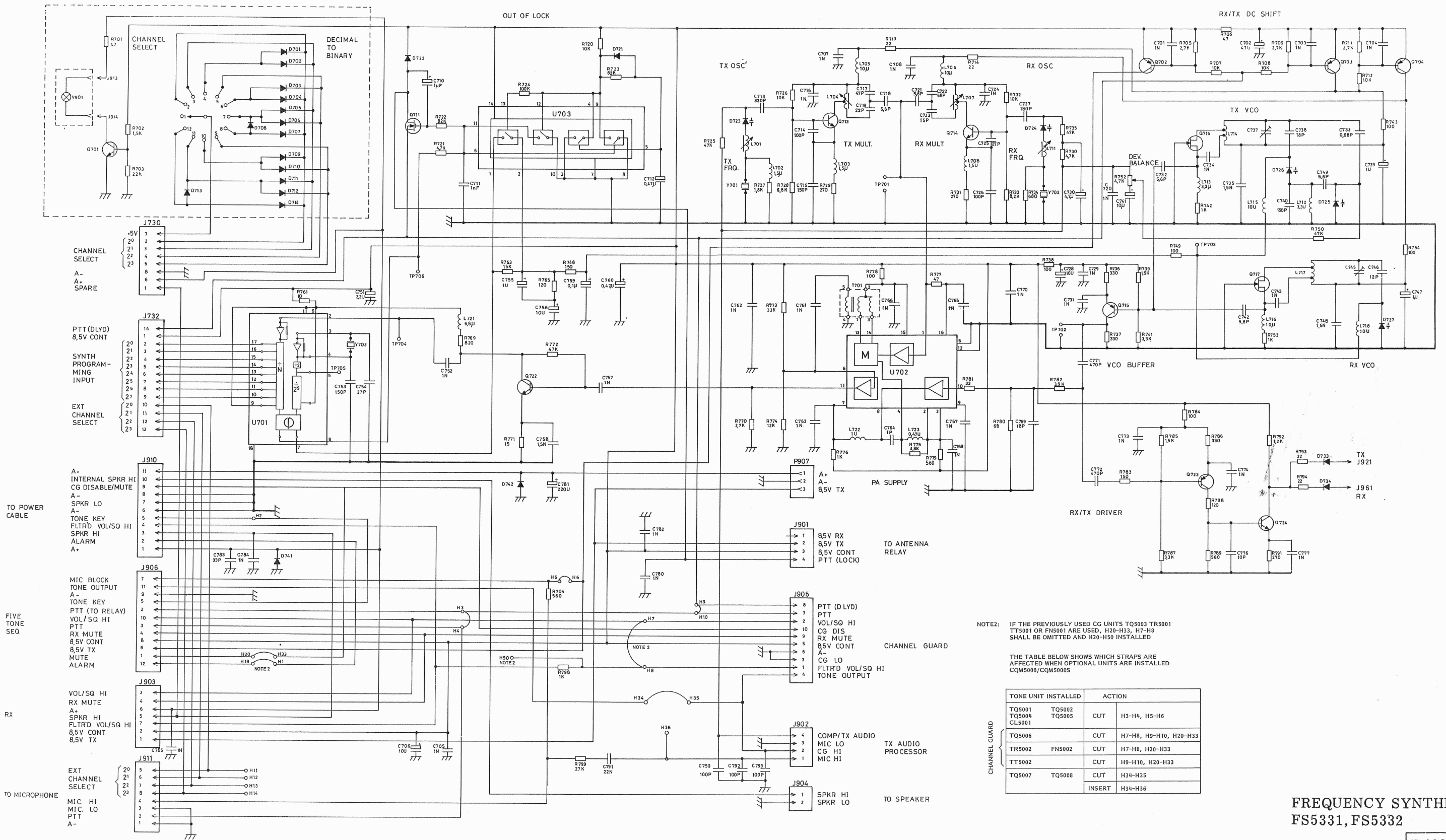

NOTE2: IF THE PREVIOUSLY USED CG UNITS TQ5003 TR5001 TT5001 OR FN5001 ARE USED, H20-H33, H7-H8 SHALL BE OMITTED AND H20-H50 INSTALLED

THE TABLE BELOW SHOWS WHICH STRAPS ARE AFFECTED WHEN OPTIONAL UNITS ARE INSTALLED CQM5000/CQM5005

TONE UNIT INSTALLED		ACTION	
TQ5001	TQ5002	CUT	H3-H4, H5-H6
TQ5004	TQ5005		
CL5001			
TQ5006		CUT	H7-H8, H9-H10, H20-H33
TR5002	FN5002	CUT	H7-H8, H20-H33
TT5002		CUT	H9-H10, H20-H33
TQ5007	TQ5008	CUT	H34-H35
		INSERT	H34-H36

FREQUENCY SYNTHESIZER
FS5331, FS5332

D402.925/4

Nº	CODE	DATA
C701	19A700233P7	1 nF Capacitor Ceramic
C702	19J706003P3	47 uF Capacitor Electrolytic
C703	19A700233P7	1 nF Capacitor Ceramic
C704	19A700233P7	1 nF Capacitor Ceramic
C705	19A700233P7	1 nF Capacitor Ceramic
C706	19A700003P7	10 uF Capacitor Tantalum
C707	19A700233P7	1 nF Capacitor Ceramic
C708	19A700233P7	1 nF Capacitor Ceramic
C711	19A700003P1	0.1 uF Capacitor Tantalum
C712	19A700003P5	2.2 uF Capacitor Tantalum
C713	19A700235P31	330 pF Capacitor Ceramic
C714	19J706256P101	100 pF N750 Capacitor Ceramic
C715	19A700235P27	150 pF Capacitor Ceramic
C716	19A700233P7	1 nF Capacitor Ceramic
C717	19A700235P21	47 pF Capacitor Ceramic
C718	19A700235P10	5.6 pF Capacitor Ceramic
C719	19A700235P17	22 pF Capacitor Ceramic
C720	19A700233P7	1 nF Capacitor Ceramic
C721	19A700235P10	5.6 pF Capacitor Ceramic
C722	19A700235P23	68 pF Capacitor Ceramic
C723	19A700235P15	15 pF Capacitor Ceramic
C724	19A700233P7	1 nF Capacitor Ceramic
C725	19J706256P203	27 pF N1500 Capacitor Ceramic
C726	19J706256P206	100 pF N1500 Capacitor Ceramic
C727	19A700235P28	180 pF Capacitor Ceramic
C728	19A700003P7	10 uF Capacitor Tantalum
C729	19A700233P7	1 nF Capacitor Ceramic
C730	19A700003P6	4.7 uF Capacitor Tantalum
C731	19A700233P7	1 nF Capacitor Ceramic
C732	19A700235P10	5.6 pF Capacitor Ceramic
C733	19A700013P11	0.68 pF Capacitor Phenolic
C734	19A700233P7	1 nF Capacitor Ceramic
C735	19A700233P8	1.5 nF Capacitor Ceramic
C737	19J706003P2	2-18 pF Capacitor Variable
C738	19A700235P16	18 pF Capacitor Ceramic
C739	19A700003P4	1 uF Capacitor Tantalum
C740	19A700235P27	150 pF Capacitor Ceramic
C741	19A700003P7	10 uF Capacitor Tantalum
C742	19A700235P10	5.6 pF Capacitor Ceramic
C743	19A700233P7	1 nF Capacitor Ceramic
C745	19J706003P2	2-18 pF Capacitor Variable
C746	19A700235P14	12 pF Capacitor Ceramic
C747	19A700003P4	1 uF Capacitor Tantalum
C748	19A700233P8	1.5 nF Capacitor Ceramic
C749	19A700235P10	5.6 pF Capacitor Ceramic
C750	19A700233P1	100 pF Capacitor Ceramic

Nº	CODE	DATA
C751	19A700003P5	2.2 uF Capacitor Tantalum
C752	19A700233P7	1 nF Capacitor Ceramic
C753	19A700233P2	150 pF Capacitor Ceramic
C754	19A700235P18	27 pF Capacitor Ceramic
C755	19A700003P4	1 uF Capacitor Tantalum
C756	19A700003P7	10 uF Capacitor Tantalum
C757	19A700233P7	1 nF Capacitor Ceramic
C758	19A700233P8	1.5 nF Capacitor Ceramic
C759	19A700003P4	1 uF Capacitor Tantalum
C760	19A700003P3	0.47 uF Capacitor Tantalum
C761	19A700233P7	1 nF Capacitor Ceramic
C762	19A700233P7	1 nF Capacitor Ceramic
C763	19A700233P7	1 nF Capacitor Ceramic
C764	19A700235P1	1 nF Capacitor Ceramic
C765	19A700233P7	1 nF Capacitor Ceramic
C766	19A700233P7	1 nF Capacitor Ceramic
C767	19A700233P7	1 nF Capacitor Ceramic
C768	19A700233P7	1 nF Capacitor Ceramic
C769	19A700235P16	18 pF Capacitor Ceramic
C770	19A700233P7	1 nF Capacitor Ceramic
C771	19A700233P5	470 pF Capacitor Ceramic
C772	19A700233P5	470 pF Capacitor Ceramic
C773	19A700233P7	1 nF Capacitor Ceramic
C774	19A700233P7	1 nF Capacitor Ceramic
C776	19A700235P13	10 pF Capacitor Ceramic
C777	19A700233P7	1 nF Capacitor Ceramic
C780	19J706005P5	220 uF Capacitor Electrolytic
C781	19A700233P7	1 nF Capacitor Ceramic
C782	19A700233P7	1 nF Capacitor Ceramic
C783	19A700235P19	33 pF Capacitor Ceramic
C784	19A700233P7	1 nF Capacitor Ceramic
C785	19A700233P7	1 nF Capacitor Ceramic
C791	19J706261P1	22 nF Capacitor Polyester
C792	19A700233P1	100 pF Capacitor Ceramic
C793	19A700233P1	100 pF Capacitor Ceramic
D721	19A700028P1	1N4148 Diode Silicon
D722	19A700028P1	1N4148 Diode Silicon
D723	19A700073P1	BB409 Variable Cap. Diode
D724	19J706262P1	Variable Cap. Diode
D725	19A700073P1	BB409 Variable Cap. Diode

NO	CODE	DATA
D726	19A700073P1	BB409 Variable Cap. Diode
D727	19A700073P1	BB409 Variable Cap. Diode
D733	19J706006P2	BA282 Diode
D734	19J706006P2	BA282 Diode
D741	19J706026P1	1N5401 Diode Silicon
D742	19J706026P1	1N5401 Diode Silicon
J730	19J706215P108	Male Connector
J732	19J706215P114	Male Connector
J901	19J706214P4	Male Connector
J902	19J706214P4	Male Connector
J903	19J706214P7	Male Connector
J904	19A700072P28	Male Connector
J905	19A700072P9	Male Connector
J906	19A700072P11	Male Connector
J907	19A700102P21	Female Connector
J910	19J706223P11	Male Connector
J911	19J706223P8	Male Connector
J921	19J706219P1	Male Connector
J961	19J706219P1	Male Connector
L701	19J706029P6	Variable Coil
L702	19A700184P1	Jumper Wire
L703	19A700184P1	Jumper Wire
L704	19J706083P6	Variable Coil
L705	19A700024P25	10 uH Coil
L706	19A700024P25	10 uH Coil
L707	19J706083P6	Variable Coil
L708	19A700024P15	1.5 uH Coil
L711	19J706029P3	Variable Coil
L712	19A700024P25	10 uH Coil
L713	19A700024P25	10 uH Coil
L714	19J706258P3	Coil
L715	19A700024P25	10 uH Coil
L716	19A700024P25	10 uH Coil
L717	19J706258P2	Coil
L718	19A700024P25	10 uH Coil
L721	19A700024P25	10 uH Coil
L722	19A700024P13	1 uH Coil
L723	19A700024P9	0.47 uH Coil
Q702	19A700020P1	BC558 Transistor
Q703	19A700020P1	BC558 Transistor
Q704	19A700020P1	BC558 Transistor
Q711	19A700017P2	BC548 Transistor
Q713	19J706283P1	BFR54 Transistor
Q714	19J706283P1	BFR54 Transistor
Q715	19J706264P1	BF414 Transistor
Q716	19J706038P1	2N5245 Transistor

NO	CODE	DATA
Q717	19J706038P1	2N5245 Transistor
Q722	19J706146P1	BF357S Transistor
Q723	19J706164P1	BF414 Transistor
Q724	19J706146P1	BF357S Transistor
R704	19A700019P34	560 ohm Resistor Depos.
R705	19A700019P42	2.7 Kohm Resistor Depos.
R706	19A700019P21	47 ohm Resistor Depos.
R707	19A700019P49	10 Kohm Resistor Depos.
R708	19A700019P49	10 Kohm Resistor Depos.
R709	19A700019P42	2.7 Kohm Resistor Depos.
R711	19A700019P42	2.7 Kohm Resistor Depos.
R712	19A700019P49	10 Kohm Resistor Depos.
R713	19A700019P17	22 ohm Resistor Depos.
R714	19A700019P17	22 ohm Resistor Depos.
R720	19A700019P37	1 Kohm Resistor Depos.
R721	19A700019P45	4.7 Kohm Resistor Depos.
R722	19A700019P60	82 Kohm Resistor Depos.
R723	19A700019P58	56 Kohm Resistor Depos.
R724	19A700019P49	10 Kohm Resistor Depos.
R725	19A700019P57	47 Kohm Resistor Depos.
R726	19A700019P49	10 Kohm Resistor Depos.
R727	19A700019P40	1.8 Kohm Resistor Depos.
R728	19A700019P47	6.8 Kohm Resistor Depos.
R729	19A700019P30	270 ohm Resistor Depos.
R730	19A700019P45	4.7 Kohm Resistor Depos.
R731	19A700019P30	270 ohm Resistor Depos.
R732	19A700019P49	10 Kohm Resistor Depos.
R733	19A700019P48	8.2 Kohm Resistor Depos.
R734	19A700019P35	680 ohm Resistor Depos.
R735	19A700029P57	47 Kohm Resistor Depos.
R736	19A700029P31	330 ohm Resistor Depos.
R737	19A700019P31	330 ohm Resistor Depos.
R738	19A700019P25	100 ohm Resistor Depos.
R739	19A700019P39	1.5 Kohm Resistor Depos.
R741	19A700019P43	3.3 Kohm Resistor Depos.
R742	19A700019P37	1 Kohm Resistor Depos.
R743	19A700019P25	100 ohm Resistor Depos.
R748	19A700019P27	150 ohm Resistor Depos.
R749	19A700019P25	100 ohm Resistor Depos.
R750	19A700019P57	47 Kohm Resistor Depos.

FREQUENCY SYNTHESIZER FS5331

X402.897/2

N ^o	CODE	DATA
R752	19A70001P3	4.7 Kohm Resistor Variable
R753	19A70001P37	1 Kohm Resistor Depos.
R754	19A70001P25	100 ohm Resistor Depos.
R761	19A70001P13	10 ohm Resistor Depos.
R763	19A70001P51	15 Kohm Resistor Depos.
R765	19A70001P26	120 ohm Resistor Depos.
R769	19A70001P35	820 ohm Resistor Depos.
R770	19A70001P42	2.7 Kohm Resistor Depos.
R771	19A70001P15	15 ohm Resistor Depos.
R772	19A70001P57	47 Kohm Resistor Depos.
R773	19A70001P55	33 Kohm Resistor Depos.
R774	19A70001P50	12 Kohm Resistor Depos.
R775	19A70001P40	1.8 Kohm Resistor Depos.
R776	19A70001P37	1 Kohm Resistor Depos.
R777	19A70001P21	47 ohm Resistor Depos.
R778	19A70001P25	100 ohm Resistor Depos.
R779	19A70001P34	560 ohm Resistor Depos.
R780	19A70001P23	68 ohm Resistor Depos.
R781	19A70001P19	33 ohm Resistor Depos.
R782	19A70001P44	3.9 Kohm Resistor Depos.
R783	19A70001P27	150 ohm Resistor Depos.
R784	19A70001P25	100 ohm Resistor Depos.
R785	19A70001P39	330 ohm Resistor Depos.
R786	19A70001P31	1.5 Kohm Resistor Depos.
R787	19A70001P43	3.3 Kohm Resistor Depos.
R788	19A70001P26	120 ohm Resistor Depos.
R789	19A70001P34	560 ohm Resistor Depos.
R791	19A70001P30	270 ohm Resistor Depos.
R792	19A70001P38	1.2 Kohm Resistor Depos.
R793	19A70001P17	22 ohm Resistor Depos.
R794	19A70001P17	22 ohm Resistor Depos.
R798	19A70001P37	1 Kohm Resistor Depos.
R799	19A70001P54	27 Kohm Resistor Depos.
T701	19J706284G1	Transformer
U701	19J706263P1	MC145106
U702	19J706238P1	INT CKT TDA 1062 S
U703	19A700029P44	4066B IC

N ^o	CODE	DATA

FREQUENCY SYNTHESIZER FS5331

X402.897/2

NO	CODE	DATA	
C701	19A700233P7	1 nF Capacitor Ceramic	50 V
C702	19J706005P3	47 uF Capacitor Electrolytic	16 V
C703	19A700233P7	1 nF Capacitor Ceramic	50 V
C704	19A700233P7	1 nF Capacitor Ceramic	50 V
C705	19A700233P7	1 nF Capacitor Ceramic	50 V
C706	19A700003P7	10 uF Capacitor Tantalum	16 V
C707	19A700233P7	1 nF Capacitor Ceramic	50 V
C708	19A700233P7	1 nF Capacitor Ceramic	50 V
C711	19A700003P1	0.1 uF Capacitor Tantalum	35 V
C712	19A700003P5	2.2 uF Capacitor Tantalum	35 V
C713	19A700235P31	330 pF Capacitor Ceramic	50 V
C714	19J706256P101	100 pF N750 Capacitor Ceramic	50 V
C715	19A700235P27	150 pF Capacitor Ceramic	50 V
C716	19A700233P7	1 nF Capacitor Ceramic	50 V
C717	19A700235P21	47 pF Capacitor Ceramic	50 V
C718	19A700235P10	5.6 pF Capacitor Ceramic	50 V
C719	19A700235P17	22 pF Capacitor Ceramic	50 V
C720	19A700233P7	1 nF Capacitor Ceramic	50 V
C721	19A700235P10	5.6 pF Capacitor Ceramic	50 V
C722	19A700235P23	68 pF Capacitor Ceramic	50 V
C723	19A700235P15	15 pF Capacitor Ceramic	50 V
C724	19A700233P7	1 nF Capacitor Ceramic	50 V
C725	19J706256P203	27 pF N1500 Capacitor Ceramic	50 V
C726	19J706256P206	100 pF N1500 Capacitor Ceramic	50 V
C727	19A700235P28	180 pF Capacitor Ceramic	50 V
C728	19A700003P7	10 uF Capacitor Tantalum	16 V
C729	19A700233P7	1 nF Capacitor Ceramic	50 V
C730	19A700003P6	4.7 uF Capacitor Tantalum	35 V
C731	19A700233P7	1 nF Capacitor Ceramic	50 V
C732	19A700235P10	5.6 pF Capacitor Ceramic	50 V
C733	19A700013P11	0.68 pF Capacitor Phenolic	500 V
C734	19A700233P7	1 nF Capacitor Ceramic	50 V
C735	19A700233P8	1.5 nF Capacitor Ceramic	50 V
C737	19J706003P2	2-18 pF Capacitor Variable	50 V
C738	19A700235P16	18 pF Capacitor Ceramic	50 V
C739	19A700003P4	1 uF Capacitor Tantalum	35 V
C740	19A700235P27	150 pF Capacitor Ceramic	50 V
C741	19A700003P7	10 uF Capacitor Tantalum	16 V
C742	19A700235P10	5.6 pF Capacitor Ceramic	50 V
C743	19A700233P7	1 nF Capacitor Ceramic	50 V
C745	19J706003P2	2-18 pF Capacitor Variable	50 V
C746	19A700235P14	12 pF Capacitor Ceramic	50 V
C747	19A700003P4	1 uF Capacitor Tantalum	35 V
C748	19A700233P8	1.5 nF Capacitor Ceramic	50 V
C749	19A700235P10	5.6 pF Capacitor Ceramic	50 V
C750	19A700233P1	100 pF Capacitor Ceramic	50 V
C751	19A700003P5	2.2 uF Capacitor Tantalum	35 V

NO	CODE	DATA	
C752	19A700233P7	1 nF Capacitor Ceramic	50 V
C753	19A700233P2	150 pF Capacitor Ceramic	50 V
C754	19A700235P18	27 pF Capacitor Ceramic	50 V
C755	19A700003P4	1 uF Capacitor Tantalum	35 V
C756	19A700003P7	10 uF Capacitor Tantalum	50 V
C757	19A700233P7	1 nF Capacitor Ceramic	50 V
C758	19A700233P8	1.5 nF Capacitor Ceramic	50 V
C759	19A700003P4	1 uF Capacitor Tantalum	35 V
C760	19A700003P3	0.47 uF Capacitor Tantalum	35 V
C761	19A700233P7	1 nF Capacitor Ceramic	50 V
C762	19A700233P7	1 nF Capacitor Ceramic	50 V
C763	19A700233P7	1 nF Capacitor Ceramic	50 V
C764	19A700235P1	1 pF Capacitor Ceramic	50 V
C765	19A700233P7	1 nF Capacitor Ceramic	50 V
C766	19A700233P7	1 nF Capacitor Ceramic	50 V
C767	19A700233P7	1 nF Capacitor Ceramic	50 V
C768	19A700233P7	1 nF Capacitor Ceramic	50 V
C769	19A700235P16	18 pF Capacitor Ceramic	50 V
C770	19A700233P7	1 nF Capacitor Ceramic	50 V
C771	19A700233P5	470 pF Capacitor Ceramic	50 V
C772	19A700233P5	470 pF Capacitor Ceramic	50 V
C773	19A700233P7	1 nF Capacitor Ceramic	50 V
C774	19A700233P7	1 nF Capacitor Ceramic	50 V
C776	19A700235P13	10 pF Capacitor Ceramic	50 V
C777	19A700233P7	1 nF Capacitor Ceramic	50 V
C780	19A700233P7	1 nF Capacitor Ceramic	50 V
C781	19J706005P5	220 uF Capacitor Electrolytic	16 V
C782	19A700233P7	1 nF Capacitor Ceramic	50 V
C783	19A700235P19	33 pF Capacitor Ceramic	50 V
C784	19A700233P7	1 nF Capacitor Ceramic	50 V
C785	19A700233P7	1 nF Capacitor Ceramic	50 V
C791	19J706261P1	22 nF Capacitor Polyester	100 V
C792	19A700233P1	100 pF Capacitor Ceramic	50 V
C793	19A700233P1	100 pF Capacitor Ceramic	50 V
D701	19A700028P1	1N4148 Diode Silicon	50 V
D702	19A700028P1	1N4148 Diode Silicon	50 V
D703	19A700028P1	1N4148 Diode Silicon	50 V
D704	19A700028P1	1N4148 Diode Silicon	50 V
D705	19A700028P1	1N4148 Diode Silicon	50 V
D706	19A700028P1	1N4148 Diode Silicon	50 V
D707	19A700028P1	1N4148 Diode Silicon	50 V

FREQUENCY SYNTHESIZER FS5332

X402. 898/2

N ^o	CODE	DATA
D708	19A700028P1	1N4148 Diode Silicon
D709	19A700028P1	1N4148 Diode Silicon
D710	19A700028P1	1N4148 Diode Silicon
D711	19A700028P1	1N4148 Diode Silicon
D712	19A700028P1	1N4148 Diode Silicon
D713	19A700028P1	1N4148 Diode Silicon
D714	19A700028P1	1N4148 Diode Silicon
D721	19A700028P1	1N4148 Diode Silicon
D722	19A700028P1	1N4148 Diode Silicon
D723	19A700073P1	BB409 Variable Cap. Diode
D724	19J706262P1	Variable Cap. Diode
D725	19A700073P1	BB409 Variable Cap. Diode
D726	19A700073P1	BB409 Variable Cap. Diode
D727	19A700073P1	BB409 Variable Cap. Diode
D733	19J706006P2	BA282 Diode
D734	19J706006P2	BA282 Diode
D741	19J706026P1	1N5401 Diode Silicon
D742	19J706026P1	1N5401 Diode Silicon
J730	19J706215P108	Male Connector
J732	19J706215P114	Male Connector
J901	19J706214P4	Male Connector
J902	19J706214P4	Male Connector
J903	19J706214P7	Male Connector
J904	19A700072P28	Male Connector
J905	19A700072P9	Male Connector
J906	19A700072P11	Male Connector
J907	19A700102P21	Female Connector
J910	19J706223P11	Male Connector
J911	19J706223P8	Male Connector
J921	19J706219P1	Male Connector
J961	19J706219P1	Male Connector
L701	19J706029P6	Variable Coil
L702	19A700184P1	Jumper Wire
L703	19A700184P1	Jumper Wire
L704	19J706083P6	Variable Coil
L705	19A700024P25	10 uH Coil
L706	19A700024P25	10 uH Coil
L707	19J706083P6	Variable Coil
L708	19A700024P15	1.5 uH Coil
L711	19J706029P3	Variable Coil
L712	19A700024P25	10 uH Coil
L713	19A700024P25	10 uH Coil
L714	19J706258P3	Coil
L715	19A700024P25	10 uH Coil
L716	19A700024P25	10 uH Coil
L717	19J706258P2	Coil
L718	19A700024P25	10 uH Coil

N ^o	CODE	DATA
L721	19A700024P23	6.8 uH Coil
L722	19A700024P13	1 uH Coil
L723	19A700024P9	0.47 uH Coil
Q701	19A700017P1	BC548 Transistor
Q702	19A700020P1	BC558 Transistor
Q703	19A700020P1	BC558 Transistor
Q704	19A700020P1	BC558 Transistor
Q711	19A700017P2	BC548 Transistor
Q713	19J706283P1	BFR54 Transistor
Q714	19J706283P1	BFR54 Transistor
Q715	19J706264P1	BF414 Transistor
Q716	19J706038P1	2N5245 Transistor
Q717	19J706038P1	2N5245 Transistor
Q722	19J706146P1	BF357S Transistor
Q723	19J706164P1	BF414 Transistor
Q724	19J706146P1	BF357S Transistor
R701	19A700019P21	47 ohm Resistor Depos.
R702	19A700019P39	1.5 Kohm Resistor Depos.
R703	19A700019P53	22 Kohm Resistor Depos.
R704	19A700019P34	560 ohm Resistor Depos.
R705	19A700019P42	2.7 Kohm Resistor Depos.
R706	19A700019P21	47 ohm Resistor Depos.
R707	19A700019P49	10 Kohm Resistor Depos.
R708	19A700019P49	10 Kohm Resistor Depos.
R709	19A700019P42	2.7 Kohm Resistor Depos.
R711	19A700019P42	2.7 Kohm Resistor Depos.
R712	19A700019P49	10 Kohm Resistor Depos.
R713	19A700019P17	22 ohm Resistor Depos.
R714	19A700019P17	22 ohm Resistor Depos.
R720	19A700019P37	1 Kohm Resistor Depos.
R721	19A700019P45	4.7 Kohm Resistor Depos.
R722	19A700019P60	82 Kohm Resistor Depos.
R723	19A700019P58	56 Kohm Resistor Depos.
R724	19A700019P49	10 Kohm Resistor Depos.
R725	19A700019P57	47 Kohm Resistor Depos.
R726	19A700019P49	10 Kohm Resistor Depos.
R727	19A700019P40	1.8 Kohm Resistor Depos.
R728	19A700019P47	6.8 Kohm Resistor Depos.
R729	19A700019P30	270 ohm Resistor Depos.
R730	19A700019P45	4.7 Kohm Resistor Depos.

FREQUENCY SYNTHESIZER FS5332

X402.898/2

Nº	CODE	DATA
R731	19A700019P30	270 ohm Resistor Depos.
R732	19A700019P49	10 Kohm Resistor Depos.
R733	19A700019P48	8.2 Kohm Resistor Depos.
R734	19A700019P35	680 ohm Resistor Depos.
R735	19A700029P57	47 Kohm Resistor Depos.
R736	19A700029P31	330 ohm Resistor Depos.
R737	19A700019P31	330 ohm Resistor Depos.
R738	19A700019P25	100 ohm Resistor Depos.
R739	19A700019P39	1.5 Kohm Resistor Depos.
R741	19A700019P43	3.3 Kohm Resistor Depos.
R742	19A700019P37	1 Kohm Resistor Depos.
R743	19A700019P25	100 ohm Resistor Depos.
R748	19A700019P27	150 ohm Resistor Depos.
R749	19A700019P25	100 ohm Resistor Depos.
R750	19A700019P57	47 Kohm Resistor Depos.
R752	19A700016P3	4.7 Kohm Resistor Variable
R753	19A700019P37	1 Kohm Resistor Depos.
R754	19A700019P25	100 ohm Resistor Depos.
R761	19A700019P13	10 ohm Resistor Depos.
R763	19A700019P51	15 Kohm Resistor Depos.
R765	19A700019P26	120 ohm Resistor Depos.
R769	19A700019P34	560 ohm Resistor Depos.
R770	19A700019P42	2.7 Kohm Resistor Depos.
R771	19A700019P15	15 ohm Resistor Depos.
R772	19A700019P57	47 Kohm Resistor Depos.
R773	19A700019P55	33 Kohm Resistor Depos.
R774	19A700019P50	12 Kohm Resistor Depos.
R775	19A700019P40	1.8 Kohm Resistor Depos.
R776	19A700010P37	1 Kohm Resistor Depos.
R777	19A700019P21	47 ohm Resistor Depos.
R778	19A700019P25	100 ohm Resistor Depos.
R779	19A700019P35	680 ohm Resistor Depos.
R780	19A700019P23	68 ohm Resistor Depos.
R781	19A700019P19	33 ohm Resistor Depos.
R782	19A700019P44	3.9 Kohm Resistor Depos.
R783	19A700019P27	150 ohm Resistor Depos.
R784	19A700019P25	100 ohm Resistor Depos.
R785	19A700019P39	1.5 Kohm Resistor Depos.
R786	19A700019P31	330 ohm Resistor Depos.
R787	19A700019P43	3.3 Kohm Resistor Depos.
R788	19A700019P26	120 ohm Resistor Depos.
R789	19A700019P34	560 ohm Resistor Depos.
R791	19A700019P30	270 ohm Resistor Depos.
R792	19A700019P38	1.2 Kohm Resistor Depos.
R793	19A700019P17	22 ohm Resistor Depos.
R794	19A700019P17	22 ohm Resistor Depos.

Nº	CODE	DATA
R798	19A700019P37	1 Kohm Resistor Depos.
R799	19A700019P54	27 Kohm Resistor Depos.
S901	19J706322G1	Channel Switch
T701	19J706284G1	Transformer
U701	19J706263P1	MC145106
U702	19J706238P1	INT CKT TDA 1062 S
U703	19A700029P44	4066B IC

TECHNICAL SPECIFICATIONS

CQM5550 S12

Guaranteed performance specifications unless otherwise noted.

Typical values are given in brackets.

GENERAL

Frequency Range

370 MHz - 420 MHz

Channel Separation

CQM5552: 25 kHz

CQM5553: 20 kHz

Maximum Frequency Deviation

CQM5552: ± 5 kHz

CQM5553: ± 4 kHz

Modulation Frequency Range

300 - 3000 Hz

Maximum RF Bandwidth

RX: 3.0 MHz

TX: 5.5 MHz

Antenna Impedance

50 ohm

Maximum Number of Channels

12

Supply Voltage

Minimum: 10.8 V

Nominal: 13.2 V

Maximum: 16.6 V

Negative potential to chassis

Temperature Range

-30°C to $+60^{\circ}\text{C}$

Dimensions

B x D x H: 180 x 190 x 60 mm

Weight

1.8 kg

RECEIVER

Sensitivity

12 dB SINAD (EIA), $\frac{1}{2}$ e.m.f.

0.4 uV (0.3uV)

Measuring conditions:

$\Delta f \pm \frac{2}{3} \times \Delta f_{\text{max}}$; $f_{\text{mod}} = 1$ kHz

20 dB SINAD (CEPT) e.m.f.

1.0 uV (0.7 uV)

$\Delta F 60\% \times \Delta f_{\text{max}}$; $f_{\text{mod}} = 1$ kHz.

Measured with psophometric filter.

Crystal Frequency Range

56 - 64 MHz

Receiver VCO Frequency Range

116 - 132 MHz

Crystal Frequency Multiplication

x2

Frequency Stability

Conforms with government regulations

Modulation Acceptance Bandwidth (EIA) ± 7 kHz (± 7.5 kHz)Adjacent Channel Selectivity

EIA

75 dB (80 dB)

CEPT

75 dB (80 dB)

Spurious Rejection

EIA

85 dB

Intermodulation Attenuation

EIA

70 dB

CEPT

70 dB (78dB)

Blocking

90 dB/uV (100 dB/uV)

Radiation

Conducted: max. 0.8 nW

Radiated: max. 0.8 nW

AF Load Impedance (Loudspeaker)

4 ohm

AF Power Output

3 W (3.6 W)

AF Distortion

5% (1.5%)

 $\Delta f = \pm 3$ kHz, 1 kHz, 1 W; RF 1 mVAudio Frequency Response, CEPT/FTZ

+1/-3 dB (+0/-1.5 dB)

Relative to 1000 Hz, -6 dB/octave

fm: 300 - 3000 Hz

Hum and Noise

Squelched: 80 dB (better than 85 dB)

Unsquelched: 55 dB (57 dB)

Recovery Time

250 ms (200 ms)

Attack Time, EIA

150 ms (110 ms)

Squelch Closing Time, EIA

150 ms (50 ms)

Current Consumption

Squelched: 350 mA (330 mA)

AF 2 W: 750 mA (730 mA)

(1 channel, without tone equipment, 13.2 V supply)

TRANSMITTER

RF Power Output

CQM5550-20 W: 20 W

 $R_L = 50$ ohmCrystal Frequency Range

59 - 68 MHz

Crystal Frequency Multiplication

x2

Transmitter VCO Frequency Range

123 - 140 MHz

Frequency Stability

Conforms with government regulations

Undesired Radiation

max. 0.2 uW

Sideband Noise Power, CEPT

less than 70 dB

AF Input Impedance

560 ohm

 $(\Delta f = \pm 3.0 \text{ kHz})$

fm = 300 Hz: max. 5%

Modulation Sensitivity90mV ± 3 dB $(\Delta f = \pm 3 \text{ kHz}, 1 \text{ kHz})$ FM Hum and Noise, CEPT55 dB (> 57 dB)

(measured with 750 usec de-emphasis)

Modulation Response (CEPT)

300 - 3000 Hz

+1/-3.0 dB (+0.5/-2 dB)

relative to 1000 Hz, 6 dB/octave

Attack time

50 ms

Modulation Distortion, CEPT

fm = 1000 Hz: max. 3%

Current Consumption

less than 5.5 A (5.0 A)

GENERAL DESCRIPTION

CQM5550 S12

The Stornophone 5000 is a mobile radiotelephone unit with self-contained controls and loudspeaker.

A comparison of the various models is presented in the table below.

Although compact in size, it contains a transmitter/receiver, optional 5-tone sequential encoder/decoder or Channel Guard, and up to 12 transmit and receive channels.

Type		CQM5552	CQM5553
SPEC		20	20
Frequency Range	MHz	370 - 420	370 - 420
RF Power	W	20	20
Channel Spacing	kHz	30/25	20
Max. Number of Channels		12	12

ACCESSORIES

Mounting frame		MC5001	Fist microphone with retractable spiral cable for mobile installation.
Power cable			
Fist microphone with retainer or Fixed - mount microphone		HS5001	Retainer for MC5001.
External loudspeaker			
External switches		HS5002	Retainer, with switches, for MC5001.
MN5001	Mounting frame for mobile installations allowing the radio to be fixed in 36 positions. Includes a base plate with locking screw.	MC704	Microphone with chock absorbing mounting bracket for mobile installation.
MN703	Desk stand for fixed installations.	MC703	Desk microphone with PTT (Push - to - Talk) switch for fixed installations.
MN704a	Mounting frame for mobile installations and direct attachment to the vehicle.	MK5001	Installation kit containing connectors, power cable, fuses and fuse holders.

LS701	Loudspeaker enclosed in plastic housing, complete with cable.
SU701	Transmitter keying switch for mounting on the steering column.
SU702	Transmitter keying switch for mounting on the dashboard.

POWER SUPPLY UNITS:

EQUIPMENT	SUPPLY VOLTAGE	
	220 V AC	+24 V DC
CQM5000, max. 6 W	PS703	PS704
CQM5000, max. 20 W	PS5001	PS702

MECHANICAL AND ELECTRICAL DESCRIPTION

The internal construction of CQM5000 is on an H-frame chassis with a shelf separating the receiver/transmitter (RF) printed circuit board and the various option printed boards. Front panel controls are an integral part of the printed board assemblies.

The chassis is a die cast aluminium frame comprising the left and right sides, the back, and a shelf located midway between the top and bottom. The chassis front is open and looks like an "H" viewed from the front.

Interconnection to the package exterior and to internal options are made via the Frequency Synthesizer board located on the option side of the H-frame. A test connector is also located on the synthesizer board and is accessible from the rear of the radio.

The moulded plastic front is directly attached to the chassis and has the speaker mounted to it. A separate moulded speaker grill and aluminum nameplate are attached to the front.

The top and bottom covers slide under the edges of the front and are then secured by screws at the rear.

The tone signalling encoder/decoder board (TQ), the Frequency Synthesizer Board (FS) and the Frequency Control (FC) mount in the top section of the chassis. Their switches and push buttons mount directly to the boards and protrude through the front.

Thin cast shields with adjustment holes are placed over the transmitter and receiver oscillators and parts of the transmitter in order to reduce spurious radiation.

CIRCUIT DESCRIPTION

RECEIVER

The receiver circuitry is placed on the main board and can be divided into:

- Receiver front end
- 1st IF section with first and second oscillator.
- 455 kHz 2nd IF section with demodulator.

(refer to functional block diagram)

FRONT-END

The receiver front-end consists of a dual-resonator input filter, a transistor RF amplifier, Q401, a triple-resonator intermediate filter and a FET mixer, Q402. The drain of the FET is terminated in the first IF resonant circuit which adapts the output impedance to the crystal filter. The front-end, antenna relay, first mixer and part of the transmitter

PA interconnections are designed in micro-stripline techniques on the mainboard.

1st IF MIXER

The first IF frequency is 21.4 MHz. The out-

put from the crystal filter is fed to a dual-gate MOS-FET amplifier, Q501, the output signal of which is fed to the second mixer, U501, a single balanced, self-oscillating, active mixer. Out of the second mixer comes the 455 kHz IF signal. Two diodes, D501-502, limit the output from the mixer.

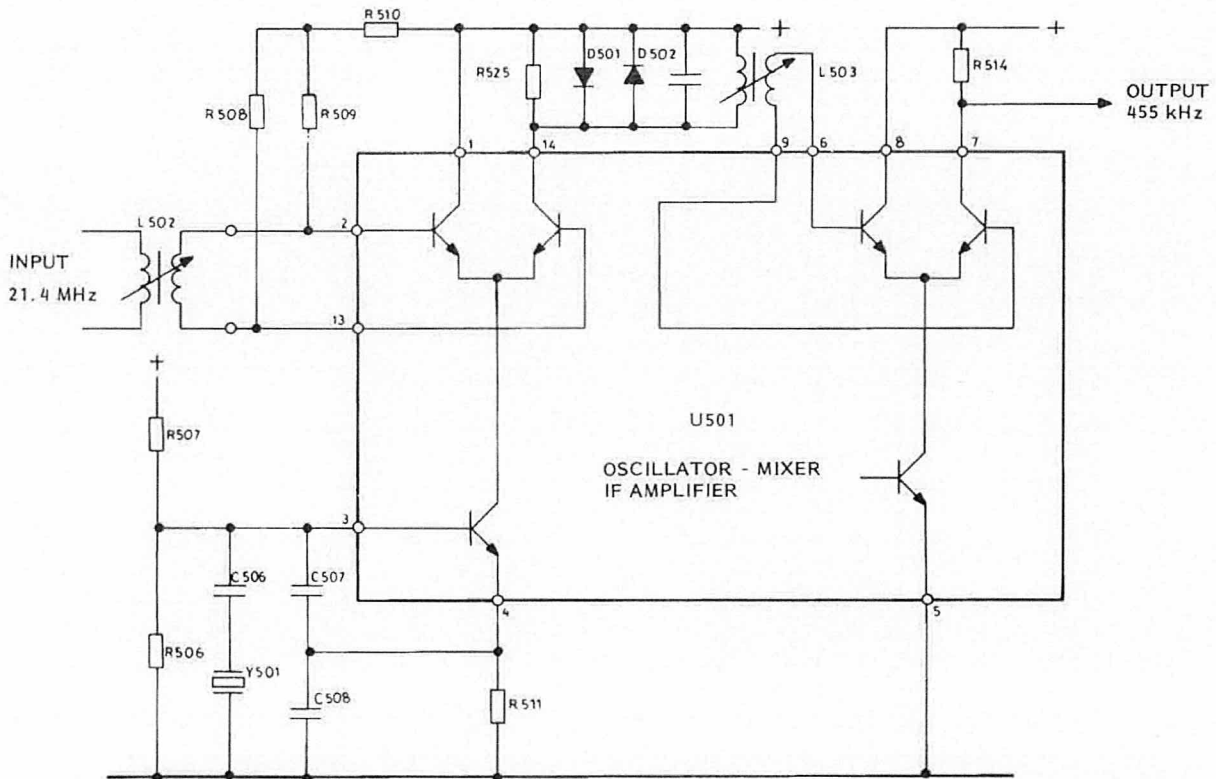

FIG. 1. SECOND OSCILLATOR , IF MIXER , AND IF AMPLIFIER

455 kHz IF AMPLIFIER AND DEMODULATOR

The selectivity of the 455 kHz IF amplifier is formed by a ceramic filter fed from a 455 kHz amplifier/impedance transforming stage. The final 455 kHz amplification and limiting is performed by an integrated circuit, U502, which also contains the quadrature FM detector and the AF amplifier/output emitter follower for the audio line signal.

SQUELCH

The audio line signal (Vol/Sq - HI) is fed to

a selective amplifier stage, where noise (frequencies around 7 kHz) is extracted from the audio signal. Via the squelch potentiometer R607, this signal reaches an expander stage which improves the level discrimination characteristics of the circuit. A passive voltage doubler circuit (D603-D604) with high source impedance performs the action of an average value rectifier. A Schmitt Trigger gives the necessary hysteresis and a well-defined output from the following buffer stage, Q605. In the squelched condition and during transmissions this output is +1.5 V and mutes the audio power amplifier. The transmit indicator

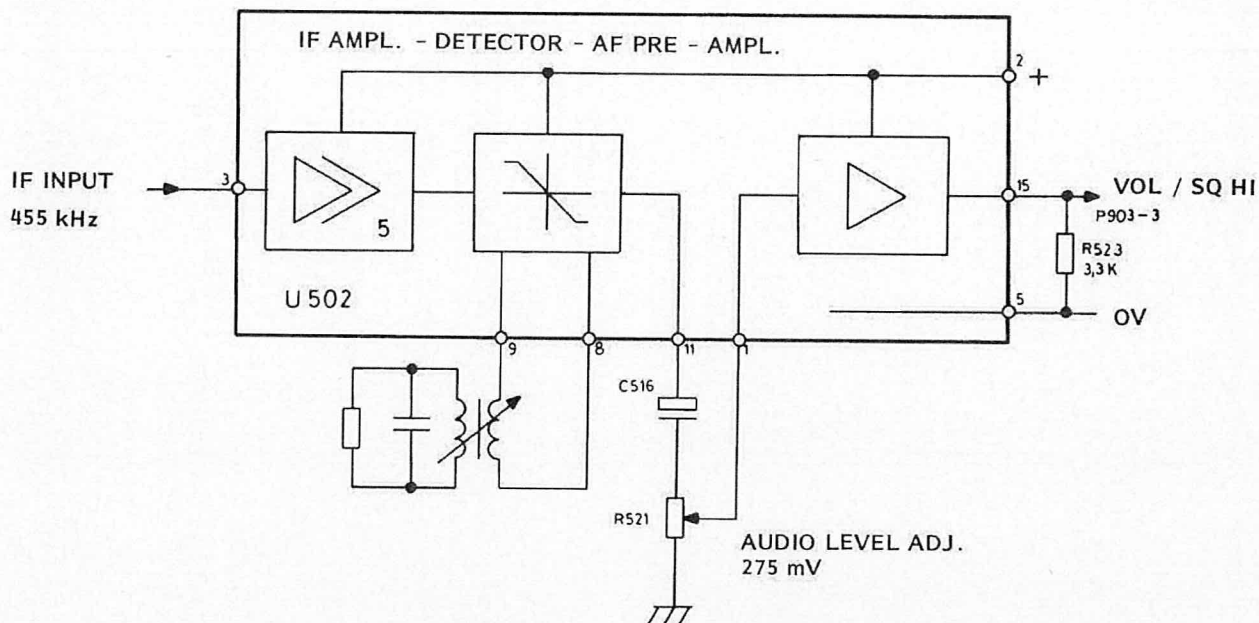

FIG. 2. IF AMPLIFIER , DETECTOR , AND AF PREAMPLIFIER

is part of the muting function.

A push button switch, S601, cancels the squelch function, when depressed, by grounding the base of Q601.

AUDIO CIRCUITS

In sets with Pilot tone option (CG), the audio line signal is fed to the Pilot tone board for filtering and back to the main board. In sets without CG this path is bypassed and the audio line signal is fed directly to the passive de-emphasis network R629-C608 followed by the volume control.

The volume control potentiometer R630 is mounted directly on the RF board and protrudes through the front panel. The audio output amplifier U601 is a monolithic IC package capable of driving the loudspeaker at the desired

power level. The output amplifier can be muted with a DC signal from the audio mute gate, which combines different logic signals to decide whether the amplifier should be active or not.

These inputs are:

- Regulated TX Voltage
- Squelch cancel
- Squelch signal

In sets equipped with Pilot tone and/or 5-tone sequential option, an RX mute function is routed from the option board to make the extra mute conditions possible.

The value of C610 in the feed back loop is chosen as the best compromise between battery ripple rejection and receiver squelch attack time.

The pilot lamp in the channel knob is supplied from A+, but controlled by the regulated 8.5 V via transistor Q968.

TRANSMITTER

The transmitter consists of a modulation processor, an exciter, and a power amplifier, all

assembled on the main board along with the receiver.

The exciter contains an audio processor, all frequency multiplier functions, and includes those stages operating at low enough power levels to avoid heat sinks.

The exciter output is at the carrier frequency when applied to the power amplifier.

The power amplifier boosts the signal to the proper level, and includes a low pass filter for suppressing harmonics and a circuitry which permits adjustment of the operating power level. The PA low pass filter connects to the antenna relay via a stripline on the board.

MODULATION PROCESSOR

The signal from the microphone load R901 on the XS board is applied to amplifier U101b.

The transmitter audio frequency response is shaped by the feedback network R104-R103-C104.

The modulation limiting is obtained in the feedback network formed by D101, D102, R105, R106 and R107. The maximum permissible frequency deviation is set by a DEV potentiometer on the RF board.

Amplifier U101A is operated as an active low-pass splatter filter feeding the modulating input of the FM oscillator.

EXCITER

The exciter takes the synthesized signal, filters it to reduce spurious signals and amplifies it. Four amplifier stages (Q201-2-3-4), of which Q202 is a frequency tripler, and three filters (L203-4, L208-9, L211-12) are used in a narrow band design which limits the maximum frequency spread of the transmitter.

The exciter has four test points (TP201-2-3-4) for measurements and alignment.

POWER AMPLIFIER

The PA is constructed on the main board and

employs two broadband untuned amplifier stages Q205, Q206. The amplifier configurations provides a power level of 20 watt. A power control circuit is included to sense the output RF level and keep it constant with variations in temperature and supply voltage. This circuit also limits the peak power to less than maximum, as specified by the authorities, while still maintaining the output as near maximum as possible.

The output power level can be set with a potentiometer, R215, over at least a 3:1 range. The transmitter delivers rated power into a 50-ohm load. A load SWR of 1.4:1 will result in more than 90% of the power being radiated. The transmitter will operate into a load with up to 3:1 SWR.

The power adjustment is achieved by controlling the supply voltage of power amplifier Q205 via transistor Q207. This series transistor is biased by a voltage generated by the feedback network C253, D201, Q210, Q209, Q208.

FREQUENCY SYNTHESIZER

The frequency synthesizer provides up to 12 channels and is built on a printed wiring board which mounts in the top section of the radio set. There are two versions of the board, a single channel board, FS5551, and a multi-channel board, FS5552.

The frequency of the single channel board is set by putting a binary code directly on the programmable divider input while the multi-channel board uses a channel selector and a Frequency Control unit, FC5001. The channel selector is mounted directly on the synthesizer board and protrudes through the front panel.

The Frequency Control unit FC5001 fits into a shield which is placed over the main section of the synthesizer board.

The Frequency Synthesizer board also carries all interconnections between the tone mo-

dules and the RF module, and it has two connectors at the rear for the accessories and the power supply cable.

SUPPLY VOLTAGE DISTRIBUTION SYSTEM

The battery voltage (A + BATT) enters the radio via two pins of the rear system connector to the synthesizer board. Both inputs are connected to reverse polarity protection diodes D901, D902. The ground lead comes through the same connector and is connected to chassis ground through a fusible printed wiring path which will open in case of the ground wire being accidentally connected to A +.

One battery input goes directly from the synthesizer board via a feed-through capacitor and a connector, P907, to the transmitter PA stages. The other input feeds through J903 to the main board for two functions. One branch for the audio amplifier passes through an RC-ripple filter R638 - C618 and one of the ON/OFF switch sections S602. The other section of the ON/OFF switch controls the $V_B +$ to the voltage regulator U602 consisting of a monolithic regulator. The regulator output

is fixed at 8.5 V by means of a factory adjusted resistor.

Regulated 8.5 V is switched to either the receiver or the transmitter by the antenna relay. The antenna relay is also supplied by the 8.5 V regulator.

The squelch circuit, the modulation processor and parts of the IF amplifier U502 are supplied directly from the continuous 8.5 V. The receiver front-end, the 21.4 MHz IF stages and the second oscillator are supplied from 8.5 V RX. The transmitter exciter is supplied from 8.5 V TX.

In sets with 5-tone sequential option or Pilot tone, the PTT (Push to talk) lead runs through the option board to provide for correct tone keying function.

WARNING

The transmitter PA transistors contain Beryllium which is poisonous when absorbed by the human body. Dissection, filing, or grinding of these transistors may be hazardous.

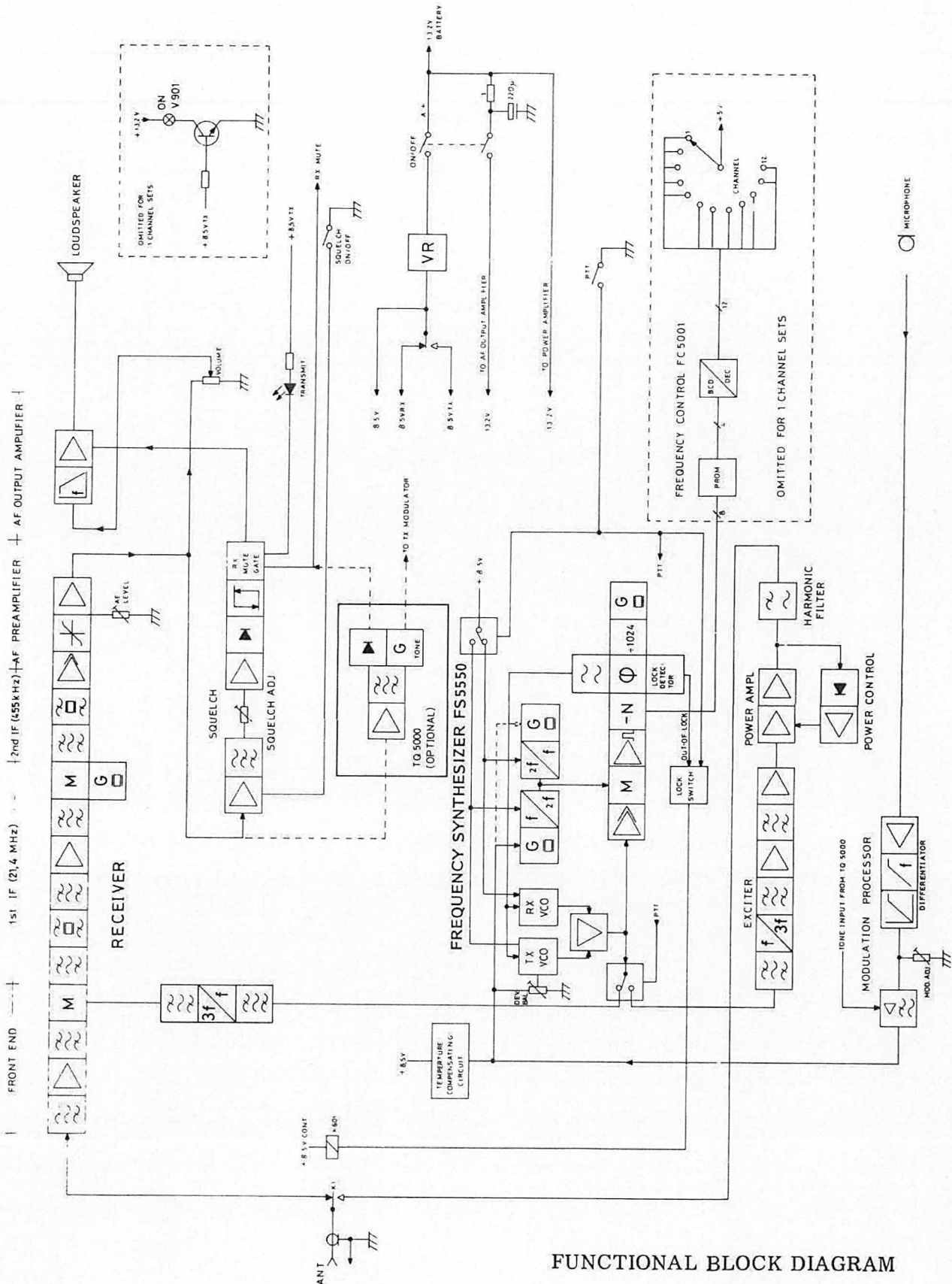

FUNCTIONAL BLOCK DIAGRAM

CQM5550xx S12

D403.030

CHANNEL PROGRAMMING INSTRUCTIONS

CQM5550 S12

Programming of the PROM which contains the data for the channel frequencies will normally be part of the factory process, but it may also be field programmed.

The PROM programming unit must be approved by the PROM manufacturer, as for example (DATA I/O SYSTEM 17 or 19).

The programmer consists of the following items:

Programmer (DATA I/O SYSTEM 19)

Programming Pak, interchangeable

Socket adaptor

or universal programming pack.

DATA I/O UNIPAK (adaptable for more than 200 types of PROM devices).

To program a PROM the channel frequencies for all allocated channels and the channel spacing must be known.

It is recommended to complete a worksheet when calculating the prom data.

It is also possible to use a computer to calculate the prom data and Storno will be able to supply software programs for certain types of computers.

Operating instructions for the Programmer is supplied by the vendor.

WORKSHEET

For each PROM to be programmed a worksheet should be completed to calculate the input data for each channel.

The procedure for completing the worksheet is:

1. Complete list of receiver channel frequencies. (A).
2. Complete list of transmitter channel frequencies. (B).
3. Find highest (H) and lowest (L) receiving frequencies.
4. Find highest (H) and lowest (L) transmitting frequencies.
5. Select receiver mixer crystal frequency (C) from table 1. The highest and lowest receiver frequencies must be within the selected band.
6. Select transmitter mixer crystal frequency (D) from table 2. The highest and lowest transmitter frequencies must be within the selected band.
7. Note channel spacing and Reference frequency (F). See worksheet.
8. Use receiver formula to calculate " V_{DEC} " (divisor) for all receiver channels.
9. Use transmitter formula to calculate " V_{DEC} " (divisor) for all transmitter channels.
10. Check " V_{DEC} " for all channels to be between 256 and 511.
11. Use receiver crystal frequency and V_{DEC} to check for selfquieting frequencies, table 3.
12. In case of selfquieting select appropriate alternative and possibly recalculate "V".
13. Convert all " V_{DEC} " numbers to hexadecimal code. Refer to tabel 4.
14. Assign the hexadecimal codes to the corresponding channels and the PROM addresses.

After completing the worksheet the next steps are:

1. Enter correct Prom addresses and corresponding data (V_{HEX}) on the Programmer (DATA I/O), refer to

Programmer Operating Instructions.

2. Insert the channel knob stop (if needed) if less than 9 channels, refer to fig. 1.
3. In case of more than 8, but less than

12 channels are used, transmission on unauthorized channels must be avoided. This is done by burning the unused channel locations in the PROM with the highest channel HEX CODE.

CHANNEL STOP

LOWEST CH.	INSERT PIN BETWEEN	HIGHEST CH.	INSERT PIN BETWEEN
1	10 and 11	1	3 and 4
2	11 and 12	2	4 and 5
3	12 and 1	3	5 and 6
4	1 and 2	4	6 and 7
5	2 and 3	5	7 and 8
6	3 and 4	6	8 and 9
7	4 and 5	7	9 and 10
8	5 and 6	8	10 and 11
9	6 and 7	9	11 and 12
10	7 and 8	10	12 and 1
11	8 and 9	11	1 and 2
12	9 and 10	12	2 and 3

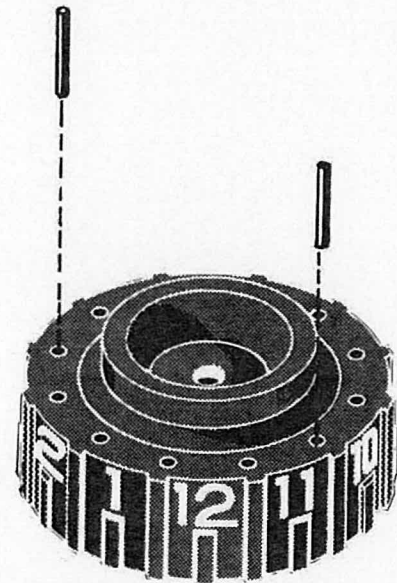

Note: If 8 channels are used insert only one PIN.
If more than 8 channels are used stop is not possible and no PINs are inserted.

Fig. 1. SETTING OF CHANNEL KNOB STOP.

RECOMMENDED CRYSTAL FREQUENCIES
CQM5550 S12

CQM5552 FREQUENCY RANGE	CQM5553 FREQUENCY RANGE	RX CRYSTAL MHz
368.9 - 375.275	367.62 - 372.72	56.85
371.4 - 377.775	370.12 - 375.22	57.266666
373.9 - 380.275	372.62 - 377.72	57.683333
376.4 - 382.775	375.12 - 380.22	58.1
378.9 - 385.275	377.62 - 382.72	58.516666
381.4 - 387.775	380.12 - 385.22	58.933333
383.9 - 390.275	382.62 - 387.72	59.35
386.4 - 392.775	385.12 - 390.22	59.766666
388.9 - 395.275	387.62 - 392.72	60.183333
391.4 - 397.775	390.12 - 395.22	60.6
393.9 - 400.275	392.62 - 397.72	61.016666
396.4 - 402.775	395.12 - 400.22	61.433333
398.9 - 405.275	397.62 - 402.72	61.85
401.4 - 407.775	400.12 - 405.22	62.266666
403.9 - 410.275	402.62 - 407.72	62.683333
406.4 - 412.775	405.12 - 410.22	63.1
408.9 - 415.275	407.62 - 412.72	63.516666
411.4 - 417.775	410.12 - 415.22	63.933333
413.9 - 420.275	412.62 - 417.72	64.35
416.4 - 422.775	415.12 - 420.22	64.766666
418.9 - 425.275	417.62 - 422.72	65.183333
421.4 - 427.775	420.12 - 425.22	65.6

TABLE 1. RECEIVER MIXER CRYSTAL FREQUENCY

RECOMMENDED CRYSTAL FREQUENCIES
CQM5550 S12

CQM5552 FREQUENCY RANGE	CQM5553 FREQUENCY RANGE	TX CRYSTAL MHz
370. - 376.375	368.72 - 373.82	60.6
372.5 - 378.875	371.22 - 376.32	61.016666
375. - 381.375	373.72 - 378.82	61.433333
377.5 - 383.875	376.22 - 381.32	61.85
380. - 386.375	378.72 - 383.82	62.266666
382.5 - 388.875	381.22 - 386.32	62.683333
385. - 391.375	383.72 - 388.82	63.1
387.5 - 393.875	386.22 - 391.32	63.516666
390. - 396.375	388.72 - 393.82	63.933333
392.5 - 398.875	391.22 - 396.32	64.35
395. - 401.375	393.72 - 398.82	64.766666
397.5 - 403.875	396.22 - 401.32	65.183333
400. - 406.375	398.72 - 403.82	65.6
402.5 - 408.875	401.22 - 406.32	66.016666
405. - 411.375	403.72 - 408.82	66.433333
407.5 - 413.875	406.22 - 411.32	66.85
410. - 416.375	408.72 - 413.82	67.266666
412.5 - 418.875	411.22 - 416.32	67.683333
415. - 421.375	413.72 - 418.82	68.1
417.5 - 423.875	416.22 - 421.32	68.516666
420. - 426.375	418.72 - 423.82	68.933333
	421.22 - 426.32	69.35

TABLE 2. TRANSMITTER MIXER CRYSTAL FREQUENCY

SELFQUIETING FREQUENCIES
CQM5552

RECEIVER CRYSTAL FREQUENCY MHz	V DEC	USE ALTERNATIVE [†]
56.850	321	4
56.850	366	4
60.183	404	2
60.600	304	2
63.100	384	4
63.516	469	4
63.933	369	4
63.933	415	4
63.933	424	4
64.350	269	4
64.350	278	4
64.350	324	4
64.350	428	4
64.766	428	4
65.183	428	4
65.600	428	4

SELFQUIETING FREQUENCIES

CQM5553

RECEIVER CRYSTAL FREQUENCY, MHz	V DEC	USE ALTERNATIVE [†]
56.850	458	4
60.183	505	4
60.600	380	4
60.600	426	4
61.016	301	4
61.850	375	4
63.933	473	4
64.350	348	4
64.350	394	4
64.350	405	4
64.766	269	4
64.766	280	4

Table 3. SELFQUIETING FREQUENCIES

[†] refer to worksheet

Least Significant Digit (LSD) of Hex Code

	0	1	2	3	4	5	6	7	8	9	A	B	C	D	E	F
0	256	257	258	259	260	261	262	263	264	265	266	267	268	269	270	271
1	272	273	274	275	276	277	278	279	280	281	282	283	284	285	286	287
2	288	289	290	291	292	293	294	295	296	297	298	299	300	301	302	303
3	304	305	306	307	308	309	310	311	312	313	314	315	316	317	318	319
4	320	321	322	323	324	325	326	327	328	329	330	331	332	333	334	335
5	336	337	338	339	340	341	342	343	344	345	346	347	348	349	350	351
6	352	353	354	355	356	357	358	359	360	361	362	363	364	365	366	367
7	368	369	370	371	372	373	374	375	376	377	378	379	380	381	382	383
8	384	385	386	387	388	389	390	391	392	393	394	395	396	397	398	399
9	400	401	402	403	404	405	406	407	408	409	410	411	412	413	414	415
A	416	417	418	419	420	421	422	423	424	425	426	427	428	429	430	431
B	432	433	434	435	436	437	438	439	440	441	442	443	444	445	446	447
C	448	449	450	451	452	453	454	455	456	457	458	459	460	461	462	463
D	464	465	466	467	468	469	470	471	472	473	474	475	476	477	478	479
E	480	481	482	483	484	485	486	487	488	489	490	491	492	493	494	495
F	496	497	498	499	500	501	502	503	504	505	506	507	508	509	510	511

Most Significant Digit of Hex Code.

"V_{DEC}" Numbers.

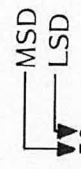

Example "V_{DEC}" = 345 equals to hex code 59.
 "V_{DEC}" = 469 equals to hex code D5.

Table 4.
 "V" Number to hex code conversion table.

Customer:

RECEIVER						TRANSMITTER					
CHAN- NEL	A FREQUENCY MHz	L H	V DEC	V HEX	PROM ADDRESS (HEX)	B FREQUENCY MHz	L H	V DEC	V HEX	PROM ADDRESS (HEX)	
1					00					10	
2					01					11	
3					02					12	
4					03					13	
5					04					14	
6					05					15	
7					06					16	
8					07					17	
9					08					18	
10					09					19	
11					0A					1A	
12					0B					1B	

RECEIVER MIXER CRYSTAL FREQ. (Y702) : C= _____

TRANSMITTER MIXER CRYSTAL FREQ. (Y701) D= _____

FORMULA: $V_{DEC} = \frac{(A - 21.4) - (C \times 6)}{3 \times F}$

FORMULA: $V_{DEC} = \frac{B - (D \times 6)}{3 \times F}$

CHANNEL SPACING:	REFERENCE CRYSTAL (Y703):	REFERENCE FREQUENCY:
20 kHz	6.8263 MHz	F= 0.006666
25 kHz	8.5333 MHz	F= 0.008333

LIST OF REFERENCE CRYSTALS (Y703)

ALTERNATIVE SOLUTIONS IF THE RECEIVER IS SELFQUIETING:

MODE	FREQUENCY, MHz	PART No.
Standard 5552	8.5333333	19J706361P3
Standard 5553	6.826666	19J706361P4

1. SELECT ANOTHER RX MIXER CRYSTAL FREQUENCY
2. SELECT HIGH INJECTION FREQUENCY FOR 2nd OSCILLATOR
Y501= 21.85500 MHz INSTEAD OF 20.94500 MHz
3. USE SLIGHTLY OFFSET REFERENCE CRYSTAL
4. WEAK QUIETING; NO ALTERNATIVE REQUIRED

ADJUSTMENT PROCEDURE

CQM5550 S12

This adjustment procedure applies to the following radiotelephone types:

CQM5552 S12 30/25 kHz Channel spacing
CQM5553 S12 20 kHz Channel spacing

Before making adjustments to the radiotelephone transmitter/receiver, read the type label and note the channel frequencies.

Check all straps according to the notes on the diagrams. Also check the selective calling tone equipment, if any, against the coding instructions; refer to description of tone equipment.

All screens must be in place and properly secured during the adjustments.

MEASURING INSTRUMENTS

The following list contains instruments necessary for adjusting the radiotelephone and checking its performance characteristics:

DC Voltmeter	$R_{in} \geq 1$ Mohm
AC Voltmeter	$Z_{in} > 1$ Mohm//50 pF
Multimeter	$R_i \geq 20$ Kohm/Volt
Distortion meter	e. g. Storno E11c
RF Watt meter	25 W/50 ohm/370-420 MHz
Deviation meter	370-420 MHz
RF generator	$Z_{out} = 50$ ohm; 370-420 MHz
21.4 MHz signal generator	e. g. Storno TS-G21B

Frequency counter with attenuator	$Z_{in} = 50$ ohm; sensitivity 100 mV at 420 MHz
RF diode probe	Storno 95.0089-00
RF coaxial probe	Storno 95.0179-00
DC power supply	10.8 V - 16.6 V; 6A
Oscilloscope	0 - 5 MHz min.

MISCELLANEOUS

4 ohm/3 W resistor	3 x Storno code 82.5026-00
22 uF/40 V electrolytic capacitor	Storno code 73.5107-00
Connector, 11-pin house	Storno code 41.5543-00
Connector, 8-pin house	Storno code 41.5542-00
Pins for connectors	Storno code 41.5551-00
Trimming tools	

The following tables show the frequency ranges of the CQM5550 S12 radiotelephone signals:

SIGNAL	FREQUENCY MHz
TX VCO	123 - 140
TX crystal	59 - 68
TX crystal multiplication	x2
RX VCO	116 - 132
RX crystal	56 - 64
RX crystal multiplication	x2

Table 1.

Channel spacing kHz	Reference Crystal MHz	Min. Divider input frequency MHz	Max. Divider input frequency MHz	Reference frequency kHz
20	6.8266	1.7066	3.4066	6.666
30 or 25 ¹⁾	5.8533	2.1333	4.2583	8.333

Table 2

¹⁾ Two steps per channel

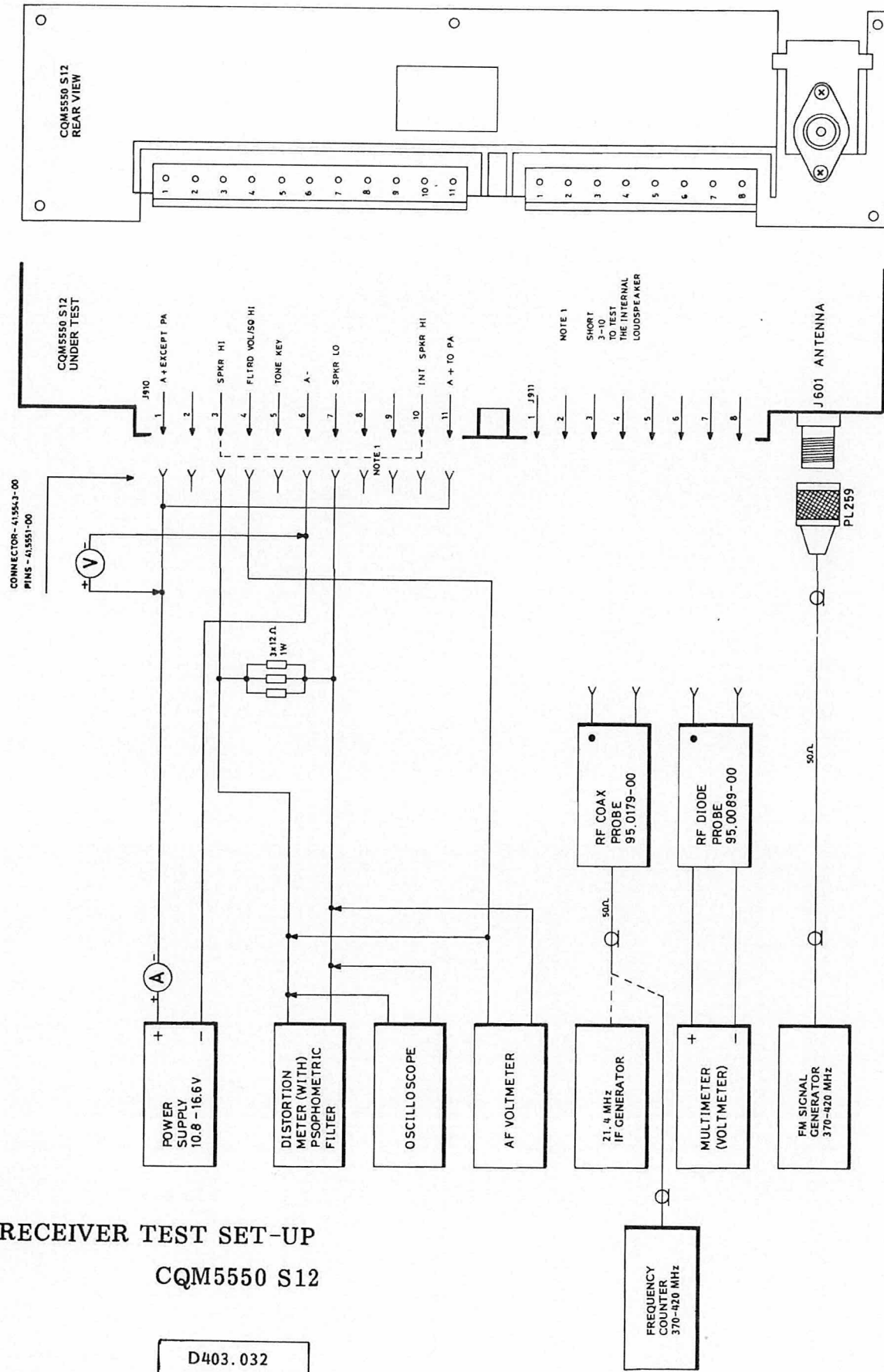

RECEIVER ADJUSTMENT

CHECKING 8.5 V REGULATED SUPPLY

Turn the power supply ON and set the voltage to 13.2 V. Set the power supply current limiter to 1 A.

Turn the radiotelephone ON by depressing the ON/OFF button. Note the light in the Channel selector, if any, is on.

Depress the Squelch button.

Set the volume control to minimum.

Connect the DC voltmeter to J901 pin 3 and read the Voltage.

Requirement: 8.5 V \pm 0.15 V

If the requirement is not fulfilled check resistor R636 against the colour code of U602.

U602 colour code	R636 ohm
Brown	omit
Red	270
Orange	100
Yellow	47
Green	22
Blue	6.8

Adjust the power supply voltage to 16.6 V and read the 8.5 V regulated. Compare the change in the 8.5 Volt regulated to the value obtained at 13.2 V.

Requirement: \leq 50 mV

Repeat the procedure with the power supply adjusted for 10.8 V

FREQUENCY SYNTHESIZER ALIGNMENT

Check the PROM U801, the TX mixer crystal, the RX mixer crystal, and the reference crystal and verify the frequencies and PROM codes.

Mixer crystal output

Connect RF diode probe 95.0089-00 with mul-

timer to test point TP701. (1 V range).

Adjust L711 for maximum deflection on the multimeter.

Adjust L707 for maximum deflection on the multimeter.

Requirement: 45 mV \pm 15 mV

(corresponding to -10 dBm to -4 dBm).

Note: Be careful not to resonate L707 to the false harmonics. If in doubt consult table 1 or check the crystal oscillator output with a spectrum analyzer.

Receiver VCO

Connect the multimeter, 10 V range, to test point TP706. The synthesizer's lock signal is accessible at TP706. +8 V DC with very narrow pulses (0.1 μ sec) indicates normal locked condition. Unlocked condition is indicated by a variable duty signal or logic "Low". Select the channel whose frequency is closest to the center frequency.

Await locked condition, constant voltage.

Adjust C745 for 8 Volts on the multimeter.

Connect the multimeter to test point TP703.

Adjust C745 for a voltage corresponding to the variable divider ratio (V) as indicated by the graph fig. 3.

Requirement: The voltage shall be in the range 1.5 V to 6.5 V and not deviate from the graph by more than 20%.

Mixer Crystal Frequency

Connect coax probe 95.0179-00 to test point TP701.

Connect the frequency counter to the probe and read the frequency.

$f = f_x \times 3$ (f_x = crystal frequency)

Adjust L711 to the calculated frequency.

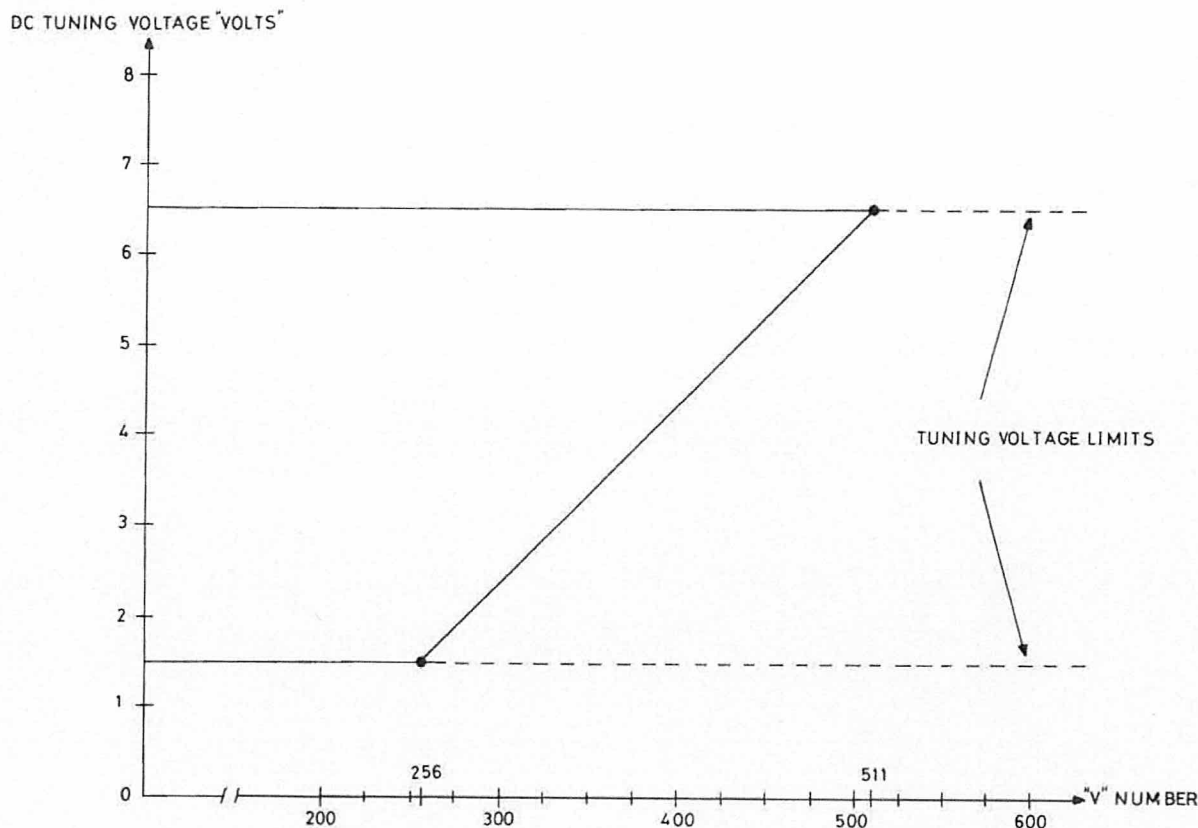

Fig. 1. Tuning voltage vs. V. number.

Requirement: $f \pm 0.3$ ppm at 25°C .
 ppm = parts per million = 10^{-6}

Injection Frequency

Connect coax probe 95.0179-00 to test point TP401.

Connect the frequency counter to the probe.
 Calculate the injection frequency for all channels.

$$f_{inj} = f_{ant} - 21.4 \text{ MHz}$$

Select, one by one, the channels and read the injection frequency.

Requirement: $F_{inj} \pm 0.2$ ppm

IF AMPLIFIERS

Connect a 21.4 MHz signal generator to TP401 via coax probe 95.0179-00.

Connect RF diode probe 95.0089-00 with multimeter to test point TP501. (50 μA range).

During adjustment the RF generator output

must be kept low enough to prevent limiting in the IF stages, i. e. a maximum reading of 50 μA on the multimeter.

Adjust coils L503, L502, L501, and L406, in that order, for maximum deflection on the multimeter.

FRONT-END

Connect the RF probe 95.0089-00 and the multimeter to test point TP501. (50 μA range).

Connect an unmodulated RF generator to the antenna connector, J601.

Set the generator frequency to the receiver frequency.

Adjust the generator output to produce a deflection on the multimeter, i. e. a maximum reading of 50 μA on the multimeter.

Adjust L401 and L402 for maximum deflection. Detune L406. Adjust L405 and L407 for maximum deflection on the multimeter.

Adjust L406 for maximum deflection.

Readjust L401 and L402 for maximum deflection.

Remove the RF diode probe.

Standard Test condition:

Connect the RF generator to antenna connector and adjust the output to 1 mV e. m. f. Modulate the RF generator with 1000 Hz to 60% of Δf max.

CQM5552 S12 ± 3 kHz

CQM5553 S12 ± 2.4 kHz

Connect a 4 ohm/3 W resistor load to connector J910/3-7 (SPKR HI-SPKR LO).

Connect an AF voltmeter to J910/4-7 (FLTD VOL SPKR LO).

IF DEMODULATOR

Turn R521 halfway up.

Adjust L504 for maximum reading on the AF voltmeter.

Connect a distortion meter and AF voltmeter across the 4 ohm resistor. (if Storno E11c distortion meter is used switch the function to AF voltmeter).

Adjust the volume control for approx. 2 V across the load.

Adjust L501 and L406 for minimum distortion. The demodulated signal may be monitored on an oscilloscope connected in parallel with the distortion meter.

Connect the AF voltmeter and distortion meter to J910/4-7 (FLTD VOL - SPKR LO).

Adjust R521 for a reading of 275 mV on the AF voltmeter.

Requirement: 275 mV ± 5 mV.

Read the distortion.

Typical Total Harmonic Distortion (THD) will be less than 5%.

RECEIVER SENSITIVITY

EIA or CEPT method may be used.

Method of measurement CEPT

The purpose of the measurement is to define the ratio of one condition to another.

The first condition is the one where a modulated RF-signal drives the receiver into full limiting. The audio output is measured with the distortion meter (in the CAL position) and, disregarding the amplitude of the audio, this is adjusted to read 100% on the meter scale; this is our reference condition consisting of signal +noise +distortion, where 'signal' is the modulation of the RF, 'noise' is the lowest possible amount achieved from that particular receiver, when receiving a strong carrier, and 'distortion' is the modulation being slightly distorted in passing through the receiver.

The second condition is the one where the signal (modulation) is removed with a notch filter and the RF-signal is lowered in amplitude until the remaining noise and distortion increases to 20 dB below the first condition, as read on the distortion meter scale. This corresponds to a reading of 10%, 10 being 20 dB below 100, which was our reference condition.

In practice our first condition is achieved by feeding a minimum of 1000 μ V of RF-signal modulated with 1000 Hz at 60% Δf max. to the receiver.

The audio output (which must be at least 100% of the receiver's audio rating) is measured through the psophometric filter, with the distortion meter in position CAL and adjusted with potentiometer ADJ. FSD. to a reading of 100.

The notch filter is then inserted in series with the audio by pressing one of the buttons marked in %. The meter needle immediately drops to indicate a low value, this being the receiver's inherent audio distortion.

By backing off the attenuator of the RF generator, thereby lowering the RF input to the receiver, the noise will eventually increase; the attenuator is now adjusted for a 10% reading on the distortion meter scale.

At this stage it must be ensured that the increased noise and the signal (with the notch filter switched out while checking) still equals 100 on the meter scale.

The RF-generator's calibrated attenuator now shows the value of RF-signal required to achieve a 20 dB ratio between signal + noise + distortion and noise + distortion, i. e. 20 dB SINAD sensitivity.

EIA Method

EIA (Electronic Industries Association) Standard, definition:

The SINAD sensitivity of a receiver is the minimum input signal that will provide at least 50% of the receiver's rated audio power with 12 dB signal + noise + distortion to noise + distortion.

The EIA method differs from CEPT by omitting the psophometric filter, adjusting the RF generator for $2/3 \times \Delta f_{max}$, and measure the distortion at 50% of the receiver's rated AF power. The SINAD sensitivity is measured as a 12 dB ratio between signal + noise + distortion and noise + distortion, which corresponds to a reading of 25% noise + distortion.

ADJUSTING THE SENSITIVITY

Lower the RF generator output to obtain 20 dB SINAD (10% THD as measured with the distortion meter). Readjust L402 for the best SINAD value, e. i. lowest generator output for 10% THD.

MEASURING 20 dB SINAD (CEPT)

Adjust the volume control for 2.45 V (1.5 W/4 ohm) as measured with an AF voltmeter across the load.

Adjust the RF generator output to obtain 20 dB SINAD condition.

Read the 20 dB SINAD sensitivity (e. m. f.)

Requirement: $\leq 1.0 \mu\text{V}$.

The sensitivity should be measured on all channels, if more than one.

MEASURING 12 dB SINAD (EIA)

Adjust the volume control for 2.45 V as measured with an AF voltmeter across the load.

Adjust the RF generator to obtain 12 dB SINAD condition.

Read the 12 dB SINAD sensitivity.

Requirement: $\leq 0.4 \mu\text{V}$ ($\frac{1}{2}$ e. m. f.)

The sensitivity should be measured on all channels, if more than one.

AUDIO FREQUENCY RESPONSE

Set the signal generator to Standard Test Condition.

Adjust the volume control for 0.82 V across the load. (4 ohm across (SPKR HI - LO).

At 13.2 V supply, $\Delta F = 60\% \Delta F_{max}$ and 1000 Hz measure the output voltage according to the following table:

	Frequency	Level	Tol.
Type CQM5552 S12	300 Hz	+9 dB	+1 dB/-3 dB
	1000 Hz	0 dB	
	3000 Hz	-9.5 dB	+1 dB/-3 dB
Type CQM5553 S12	300 Hz	+10.5 dB	+1.5 dB/-3 dB
	400 Hz	+8 dB	+1.5 dB/-1.5 dB
	1000 Hz	0 dB	
	2700 Hz	-8.6 dB	+1.5 dB/-1.5 dB
	3000 Hz	-9.5 dB	+1.5 dB/-3 dB
	6000 Hz	<-20 dB	

SELF QUIETING CHECK

Internal oscillators, dividers and the harmonic frequencies hereof, may cause self quieting of the receiver if a mixer product falls in the RF or IF pass band.

For proper operation of the squelch all channels must be checked for the self quieting phenomenon.

Connect the RF generator to the antenna connector. Reduce the RF output to 0.

Set the frequency outside the 420 - 470 MHz band.

Alternatively, an attenuator (50 ohm) may be connected to the antenna connector.

Connect an AF voltmeter across the 4 ohm speaker load.

Adjust the volume control for 774 mV (0 dBm) as read on the AF voltmeter.

Select, in turn, all allocated channels.

The reading on the AF voltmeter shall not on any selected channel decline more than 6 dB.

Requirement: Quieting ≤ 6 dB.

AF POWER OUTPUT

Adjust the RF signal generator to Standard Test Condition.

Set the supply voltage to 13.2 V.

Adjust the volume control for 3 W output (3.46 V across the 4 ohm load).

Measure the distortion (THD).

Requirement: THD $\leq 5\%$.

SQUELCH

Release the squelch cancel button.

Adjust potentiometer R607 squelch adj. to open the receiver for an RF input signal corresponding to 8-10 dB SINAD.

The final squelch adjustment must not be set on a channel that has shown a minor degree of selfquieting.

CURRENT CONSUMPTION

Measure the current consumption at 13.2 V.

Requirements

Condition	Current consumption
Standby	≤ 400 mA
Receive 2 W AF ~ 2.83 V r. m. s. across 4 ohm.	≤ 750 mA

For sets with selective calling facilities add current consumption of the tone unit to the figures above.

TRANSMITTER ADJUSTMENT

Adjust the power supply voltage to 13.2 V and set current limiter as follows:

20 W transmitter: 6A

5 W transmitter: 4A

Refer to Receiver Alignment for measuring 8.5 V regulated supply.

Preset all transmitter tuning slugs, L151, L153, L201, L202, L204, and L205 to be flush with the coil form top.

Connect a multimeter (2.5 volt range) to test point TP201.

Turn the power control potentiometer, R221, to minimum, anticlockwise (CCW).

Connect a Wattmeter, (25 W) to the antenna connector, J601.

FREQUENCY SYNTHESIZER ALIGNMENT

Check the PROM U801, the TX mixer crystal, the RX mixer crystal, and the reference crystal and verify the frequencies and the prom codes.

Mixer crystal output

Connect RF probe 95.0089-00 with multimeter to test point TP701 (1 V range).

Key the transmitter.

Adjust L701 for maximum deflection on the multimeter.

Adjust L704 for maximum deflection on the multimeter.

Requirement:

40 mV \pm 15 mV

(corresponding to -10 dBm to -4 dBm)

Note: Be careful not to resonate L704 to the false harmonics. If in doubt consult table 1 or check the crystal oscillator output with a spectrum analyzer.

Transmitter VCO

Connect the multimeter, 10 V range, to test point TP706.

The synthesizer's lock signal is accessible at TP706 and +8 V DC with very narrow pulses (0.1 μ sec.) indicate normal locked condition. Unlocked condition is indicated by a variable duty signal or logic "LOW".

Select the channel whose frequency is closest to the center frequency. Key the transmitter. Await locked condition. Adjust C737 for 8 Volts on the multimeter.

Connect the voltmeter to test point TP703. Adjust C737 for a voltage corresponding to the variable divider ratio (V) as indicated by the graph fig. 3.

Requirement: The voltage shall be in the range 1.5 V to 6.5 V and not deviate from the graph by more than 20%.

Mixer Crystal Frequency

Connect coax probe 95.0179-00 to test point TP701.

Connect the frequency counter to the probe, key the transmitter and read the frequency. $f = f_x \times 3$ (f_x = crystal frequency).

Adjust L701 to the calculated frequency.

Requirement: $f \pm 0.3$ ppm at 25°C.

ppm = parts per million = 10^{-6} .

Synthesizer Output Level

Connect a multimeter, 2.5 V range, to test point TP201. Key the transmitter.

Adjust L153 for maximum deflection on the multimeter, typical more than 0.75 V.

EXCITER, COARSE ADJUSTMENT

Connect a multimeter (1.0 V range) to test point TP201.

Adjust L203 for minimum deflection. The dip is small.

Connect the multimeter, (1 V range) to test point TP202.

Adjust L204 for maximum deflection on the multimeter, typical 0.9 V.

Repeat the adjustments of L203, L153, and L151 (L921-L926) until no further improvements is obtainable.

Adjust C213 for minimum reading. The dip is small.

Connect the multimeter, 1 volt range, to test point TP203.

Adjust C215 for maximum reading on the multimeter, typical 0.5 V.

Repeat the adjustment of C213 and L204 until no further improvement is obtainable.

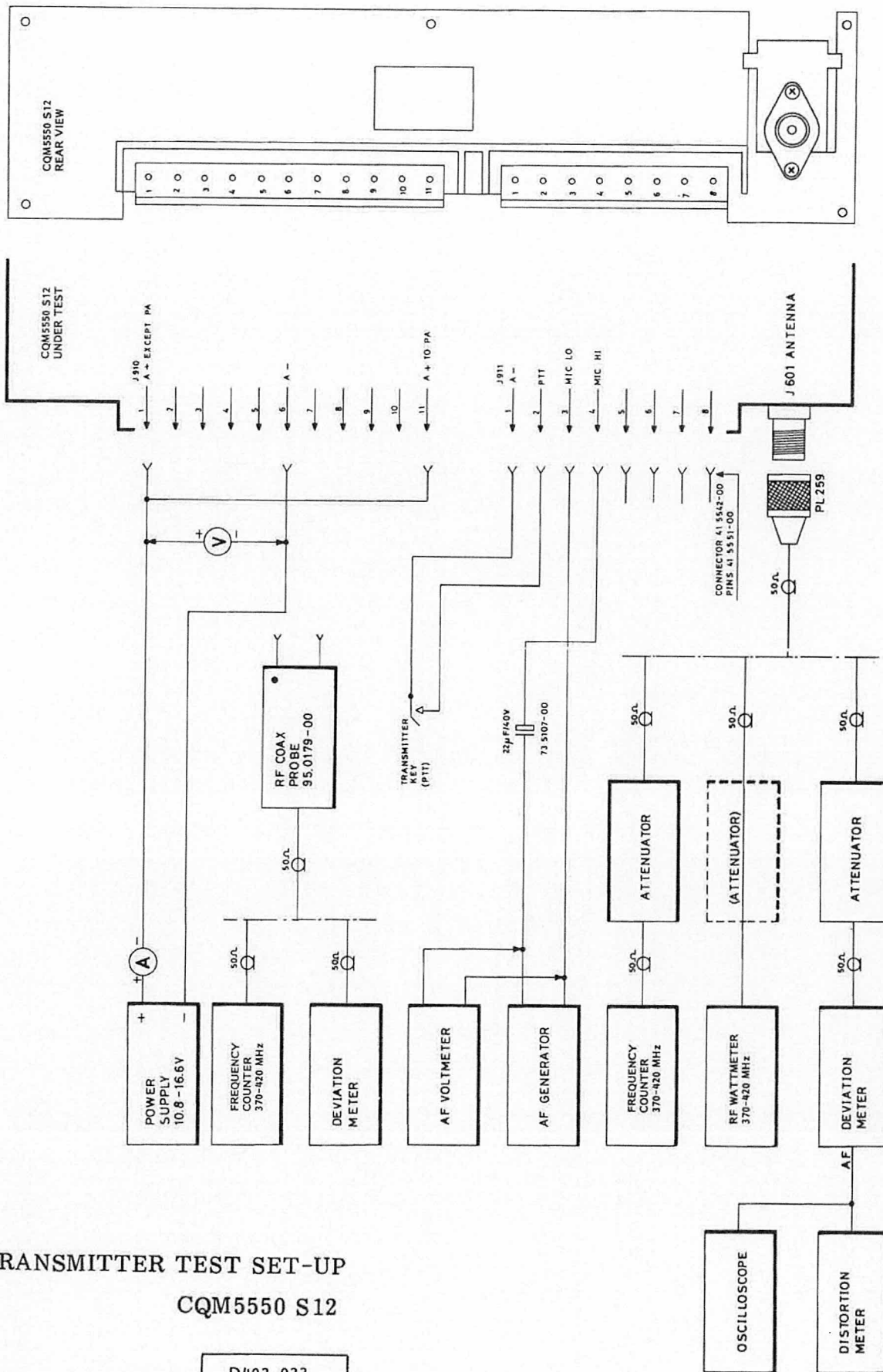

TRANSMITTER TEST SET-UP
CQM5550 S12

D403.033

Adjust C221 to minimum deflection. The dip is small and careful tuning is required.

Connect the multimeter, 10 volt range, to the RF probe.

Connect RF diode probe 95.0089-00 to TP204. Adjust C221 and C223 for maximum deflection (typical 4.0 V).

Adjust the PA power control, R215, for rated transmitter power, 5 W or 20 W.

EXCITER, FINE ADJUSTMENT

Connect the multimeter to test point TP201.

Readjust L153 for maximum reading.

Connect the multimeter to test point TP202.

Peak L203 and L204 for maximum reading.

Connect the multimeter to test point TP203.

Peak C213 and C215 for maximum reading.

Connect the 95.0089-00 RF probe and multimeter to TP204.

Adjust C221 and C223 for maximum reading.

TYPICAL TEST POINT READINGS

TP201:	0.5 V
TP202:	0.9 V
TP203:	0.5 V
TP204:	4.0 V

TRANSMITTER FREQUENCY ADJUSTMENT

Connect a frequency counter through a suit-

able attenuator to the antenna connector J601. Key the transmitter.

Select one by one, the channels and read their frequencies.

Adjust L701 for best frequency tracking on all channels.

Requirement: $F = F_{ant} \pm 0.2 \text{ ppm}$,
ppm = parts per million = 10^{-6}

RF POWER OUTPUT, CURRENT CONSUMPTION, AND POWER CONTROL

Connect the Watt meter to the antenna connector, J601.

Increase the supply voltage to 13.2 V. The voltage is measured directly at the input connector J910.

Readjust the PA power control, R221, for rated transmitter power (P), 20 W or 5 W.

Requirement: $P_{nom} \pm 0.2 \text{ dB}$.

Measure the RF power output at 16 V, 13.2 V and 10.8 V.

Requirements (20 W):

Voltage	Power	Current
16 V	$\leq 25 \text{ W (ref)}$	5.4 A
13.2 V	20 W	5.4 A
10.8 V	$\geq 12 \text{ W}$	5.4 A

Requirements (5 W):

Voltage	Power	Current
16 V	$\leq 6.5 \text{ W}$	1.7 A
13.2 V	5 W	1.7 A
10.8 V	$\geq 3.5 \text{ W}$	1.7 A

MODULATION ADJUSTMENT

Set the power supply voltage to 13.2 V.

Select the channel having the highest frequency. Set R116 to mid-position.

Connect coax probe 95.0179-00 to test point TP701.

Connect a deviation meter to the coax probe.

Connect a distortion meter and oscilloscope

to the deviation meter output.

Connect a AF generator and an AF Voltmeter to the microphone input via a 22 uF capacitor; refer to test setup.

Set the AF generator to 1000 Hz.

Adjust the AF generator output to 1 V r.m.s. This voltage is approx. 20 dB above the nominal modulation input level (60% Δf max) to

ensure full limiting in the modulation processor.

Note the deviation read at TP701.

Connect the deviation meter to test point TP702.

Adjust R752 (Dev. Bal.) for same deviation as measured at TP701.

Connect the deviation meter through an attenuator to the antenna connector, J601.

Connect a distortion meter and oscilloscope to the deviation meter output.

Connect an AF generator and an AF Voltmeter to the microphone input via a 22 μ F capacitor; refer to test setup.

Set the AF generator to 1000 Hz.

Adjust the AF generator output to 1 V r. m. s. This voltage is approx. 20 dB above the nominal modulation input level (60% Δf max) to ensure full limiting in the modulation processor.

Find the AF frequency between 200 Hz and 3000 Hz giving the greatest frequency deviation as read on the deviation meter with the transmitter keyed.

Check the maximum deviation for both positive and negative deviation polarity. At that audio frequency set the maximum frequency deviation Δf max with R116.

Type	Channel spacing	Δf max
CQM5552 S12	30/25 kHz	± 5 kHz
CQM5553 S12	20 kHz	± 4 kHz

Requirement

Difference between + and - deviation: $\leq 10\%$

MODULATION SENSITIVITY AND MODULATION DISTORTION

Set the AF generator frequency to 1000 Hz
Adjust the generator output until 60% of Δf max is obtained on the deviation meter.

CQM5552 S12 : ± 3.0 kHz

CQM5553 S12 : ± 2.4 kHz

Read the AF generator output and measure the modulation distortion on the audio output of the deviation meter.

Requirements:

Modulating signal: 75 mV ± 3 dB

Distortion: $\leq 7\%$

(measured without deemphasis)

MODULATION FREQUENCY RESPONSE

Set the AF generator to 1000 Hz.

Reduce the AF generator output until a deviation of $0.2 \times \Delta f$ max is obtained on the deviation meter.

CQM5552 S12 : ± 1.0 kHz

CQM5553 S12 : ± 0.8 kHz

Vary the frequency of the generator and note the deviation changes as referred to the 1000 Hz value.

Requirement :

Within the frequency range 400-2700 Hz the frequency characteristic shall lie within +1 dB/-1.5 dB related to a 6 dB/octave characteristic.

With 6 kHz modulation frequency the deviation shall be attenuated at least 6 dB below the 1 kHz value.

ADJUSTMENT OF TONE EQUIPMENT

Measuring equipment

Tone Test Generator Storno TS-G13
95B0251-00

Check the connections and the tone combination of the TQ5001/TQ5002/TQ5004/TQ5005 and SU/5002; refer to description and diagrams.

Adjustment of frequency deviation

Apply Standard test condition to the transmitter; refer to transmitter test setup.

Establish a shortcircuit between emitter and collector of Q108, on the solder side of the TQ unit, which will produce a continuous tone to the modulator.

Key the transmitter using the tone button.

Adjust R113, TQ5001/TQ5002/TQ5004/TQ5005 for 70% of maximum frequency deviation.

Remove the short circuit.

Connect the G13 Tone Test set to the AF output on the Deviation Meter.

Check that the tone call is properly received when the tone button is depressed.

Checking the Tone Receiver

Apply Standard test condition to the receiver; refer to receiver test setup.

Modulate the signal generator with the G13 Tone Test Set.

Set the G13 to the proper tone combination.

Check that the TQ unit responds to a released tone call.

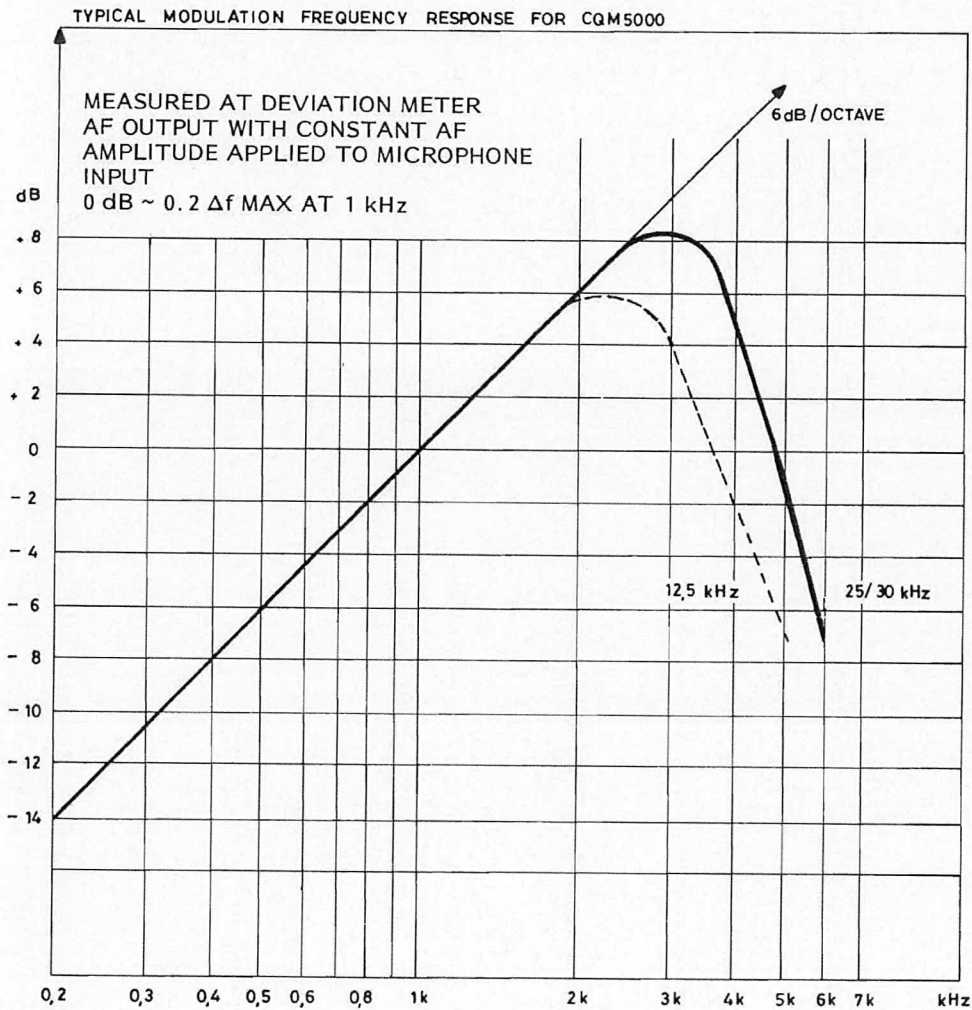

TECHNICAL SPECIFICATIONS

CQM5550 S99

Guaranteed performance specifications unless otherwise noted.

Typical values are given in brackets.

GENERAL

Frequency Range

370 MHz - 420 MHz

Channel Separation

CQM5552: 25 kHz

Maximum Frequency Deviation

CQM5552: ± 5 kHz

Modulation Frequency Range

300 - 3000 Hz

Maximum RF Bandwidth

RX: 3.0 MHz

TX: 5.5 MHz

Antenna Impedance

50 ohm

Maximum Number of Channels

99

Supply Voltage

Minimum: 10.8 V

Nominal: 13.2 V

Maximum: 16.6 V

Negative potential to chassis

Temperature Range

-30°C to $+60^{\circ}\text{C}$

Dimensions

B x D x H: 180 x 190 x 60 mm

Weight

1.8 kg

RECEIVER

Sensitivity

12 dB SINAD (EIA), $\frac{1}{2}$ e. m. f.

0.4 μV (0.3 μV)

Measuring conditions:

$\Delta f \pm 2/3 \times \Delta f_{\text{max}}$; $f_{\text{mod}} = 1$ kHz

20 dB SINAD (CEPT) e. m. f.

1.0 μV (0.7 μV)

$\Delta F 60\% \times \Delta f_{\text{max}}$; $f_{\text{mod}} = 1$ kHz.

Measured with psophometric filter.

Crystal Frequency Range

56.85 - 65.6 MHz

Receiver VCO Frequency Range

116 - 132 MHz

Crystal Frequency Multiplication

x2

Frequency Stability

Conforms with government regulations

Modulation Acceptance Bandwidth (EIA) ± 7 kHz (± 7.5 kHz)Adjacent Channel Selectivity

EIA

75 dB (80 dB)

CEPT

75 dB (80 dB)

Spurious Rejection

EIA

85 dB

Intermodulation Attenuation

EIA

70 dB

CEPT

70 dB (78dB)

Blocking

90 dB/uV (100 dB/uV)

Radiation

Conducted: max. 0.8 nW

Radiated: max. 0.8 nW

AF Load Impedance (Loudspeaker)

4 ohm

AF Power Output

3 W (3.6 W)

AF Distortion

5% (1.5%)

 $\Delta f = \pm 3$ kHz, 1 kHz, 1 W; RF 1 mVAudio Frequency Response, CEPT

+1/-3 dB (+0/-1.5 dB)

Relative to 1000 Hz, -6 dB/octave

fm: 300 - 3000 Hz

Hum and Noise

Squelched: 80 dB (better than 85 dB)

Unsquelched: 55 dB (57 dB)

Recovery Time

250 ms (200 ms)

Attack Time, EIA

150 ms (110 ms)

Squelch Closing Time, EIA

150 ms (50 ms)

Current Consumption

Squelched: 1000 mA (750 mA)

AF 2 W: 1450 mA (1150 mA)

(13.2 V supply)

TRANSMITTER

RF Power Output

CQM5550-20 W: 20 W

 $R_L = 50$ ohmCrystal Frequency Range

60.6 - 69.35 MHz

Crystal Frequency Multiplication

x2

Transmitter VCO Frequency Range

123 - 140 MHz

Frequency Stability

Conforms with government regulations

Undesired Radiation

max. 0.2 uW

Sideband Noise Power, CEPT

less than 70 dB

AF Input Impedance

560 ohm

Modulation Sensitivity

90mV \pm 3 dB

($\Delta f = \pm 3$ kHz, 1 kHz)

Modulation Response (CEPT)

300 - 3000 Hz

+1/-3.0 dB (+0.5/-2 dB)

relative to 1000 Hz, 6 dB/octave

Modulation Distortion, CEPT

fm= 1000 Hz: max. 3%

($\Delta f = \pm 3.0$ kHz)

fm= 300 Hz: max. 5%

FM Hum and Noise, CEPT

55 dB (>57 dB)

(measured with 750 usec de-emphasis)

Attack time

50 ms

Current Consumption

less than 6.2 A (5.5 A)

GENERAL DESCRIPTION

CQM5550 S99

The Stornophone 5000 is a mobile radiotelephone unit with self-contained controls keyboard and display.

A comparison of the various models are presented in the table below.

Although compact in size, it contains a transmitter/receiver, a microcomputer controlled synthesizer and tone equipment, optional 5-

tone sequential encoder/decoder or Channel Guard, and up to 99 transmit and receive channels.

Type	CQM5552 S99
SPEC	20
Frequency Range MHz	370 - 420
RF Power W	20
Channel Spacing kHz	30/25
Max. Number of Channels	99

ACCESSORIES

Standard accessories include:

Mounting frame

Power cable

Fist microphone with retainer or

Fixed - mount microphone

External loudspeaker

External switches

MN5001 Mounting frame for mobile installations allowing the radio to be fixed in 36 positions. Includes a base plate with locking screw.

MN703 Desk stand for fixed installations.

MN704a Mounting frame for mobile installations and direct attachment to the vehicle.

MC5001 Fist microphone with retractable spiral cable for mobile installation.

HS5001 Retainer for MC5001.

HS5002 Retainer, with switches, for MC5001

MC704 Microphone with chockabsorbing mounting bracket for mobile installation.

MC703 Desk microphone with PTT switch for fixed installations.

MK5001 Installation kit containing connectors, power cable, fuses and fuseholders.

LS701 Loudspeaker enclosed in a plastic housing, complete with cable.

SU701 Transmitter keying switch for mounting on the steering column.

SU702 Transmitter keying switch for mounting on the dashboard.

PS702 Power supply regulator for 24 V car battery installations.

PS5001 Power supply for 220 V AC mains.

MECHANICAL AND ELECTRICAL DESCRIPTION

The internal construction of CQM5000 is on an H-frame chassis with a shelf separating the receiver/transmitter (RF) printed circuit board and the various option printed boards. Front panel controls, display and keyboard are an integral part of the Control Panel.

The chassis is a die cast aluminium frame comprising the left and right sides, the back, and a shelf located midway between the top and bottom. The chassis front is open and looks like an "H" viewed from the front.

Interconnection to the package exterior and to internal options are made via the Frequency Synthesizer Board located on the option side of the H-frame. A test connector is also located on the synthesizer board and is accessible from the rear of the radio.

The moulded plastic front is directly attached to the chassis and has the speaker mounted to it. A separate moulded control panel and aluminum nameplate are attached to the front.

The top and bottom covers slides under the edge of the front and are then secured by screws at the rear.

The tone signalling encoder/decoder board (TQ), the Frequency Synthesizer Board (FB), and the Control Logic (CL) mount in the top section of the chassis.

Thin casted shields with adjustment holes are placed over the RF board and the synthesizer board in order to reduce spurious radiation.

RECEIVER DESCRIPTION

The receiver circuitry is placed on the RF board and can be divided into:

- Receiver front end
- 1st IF section with first and second oscillator
- 455 kHz 2nd IF portion with demodulator.
- Squelch
- Audio Amplifier

(refer to functional block diagram)

FONT-END

The receiver front-end consists of a dual-resonator input filter, a transistor RF amplifier, Q401, a triple-resonator intermediate filter and a FET mixer, Q402. The drain of the FET

is terminated in the first IF resonant circuit which adapts the output impedance to the crystal filter. The front-end, antenna relay, first mixer and part of the transmitter PA interconnections are designed in micro-stripline techniques on the mainboard.

1st IF

The first IF frequency is 21.4 MHz. The output from the crystal filter is fed to a dual-gate MOSFET amplifier, Q501, the output signal of which is fed to the second mixer, U501, a single balanced, self-oscillating, active mixer. Out of the second mixer comes the 455 kHz IF signal. Two diodes, D501-502, limit the output from the mixer.

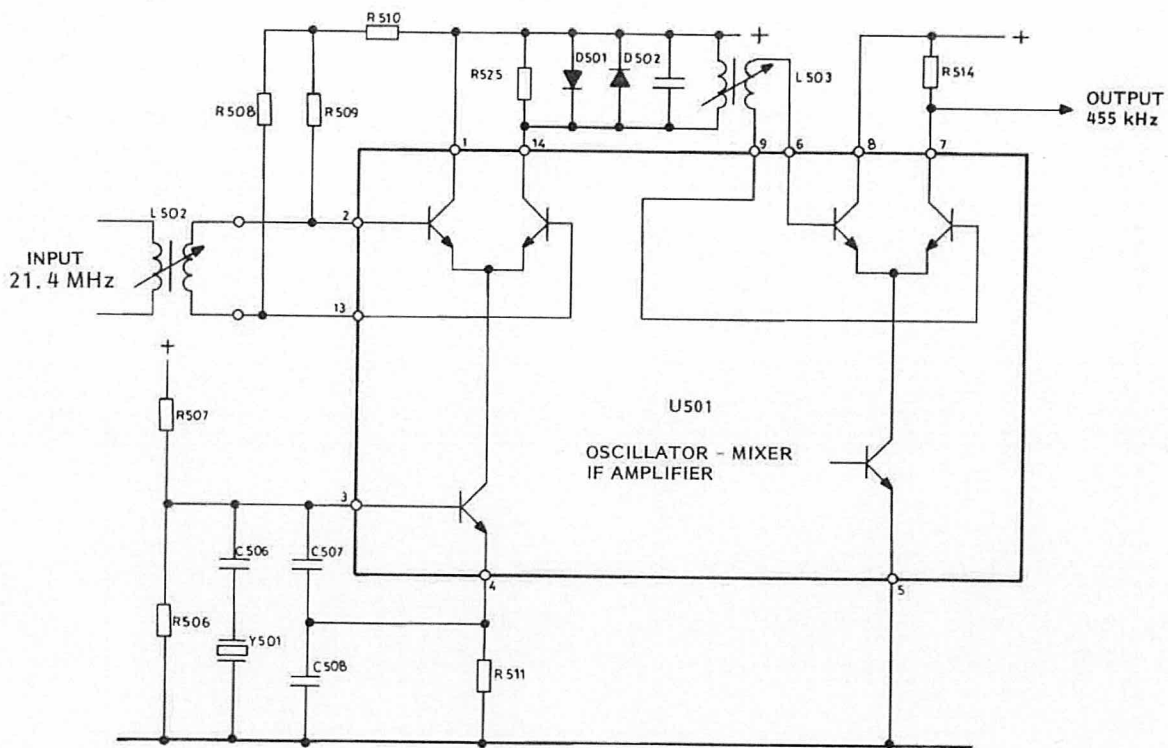

FIG. 1. SECOND OSCILLATOR , IF MIXER , AND IF AMPLIFIER

455 kHz IF/DEMODULATOR

The selectivity of the 455 kHz IF amplifier is formed by a ceramic filter fed from a 455 kHz amplifier/impedance transforming stage. The final 455 kHz amplification and limiting is performed by an integrated circuit , U502, which also contains the quadrature FM detector and the AF amplifier/output emitter follower for the audio line signal.

SQUELCH AND AUDIO CIRCUITS

The audio line signal (Vol/Sq - HI) is fed to a selective amplifier stage, where noise (frequencies around 8 kHz) is extracted from the audio signal. Via the squelch potentiometer R607, this signal reaches an expander stage which improves the level discrimination characteristics of the circuit. A passive voltage doubler circuit (D603-D604) with high source impedance performs the action of an average value rectifier. A Schmitt Trigger gives the

necessary hysteresis and a well-defined output from the following buffer stage, Q605.

In the squelched condition and during transmissions this output is +1.5 V and mutes the audio power amplifier. The transmit indicator is part of the muting function.

A push button switch, S601, cancels the squelch function, when depressed, by grounding the base of Q601.

AUDIO

In sets with Pilot tone option (CG), the audio line signal is fed to the Pilot tone board for filtering and back to the main board. In sets without CG this path is bypassed and the audio line signal is fed directly to the passive deemphasis network R629-C608 followed by the volume control. The volume control potentiometer R630 is mounted directly on the RF board and protrude through the front panel. The audio output amplifier U601 is a monoli-

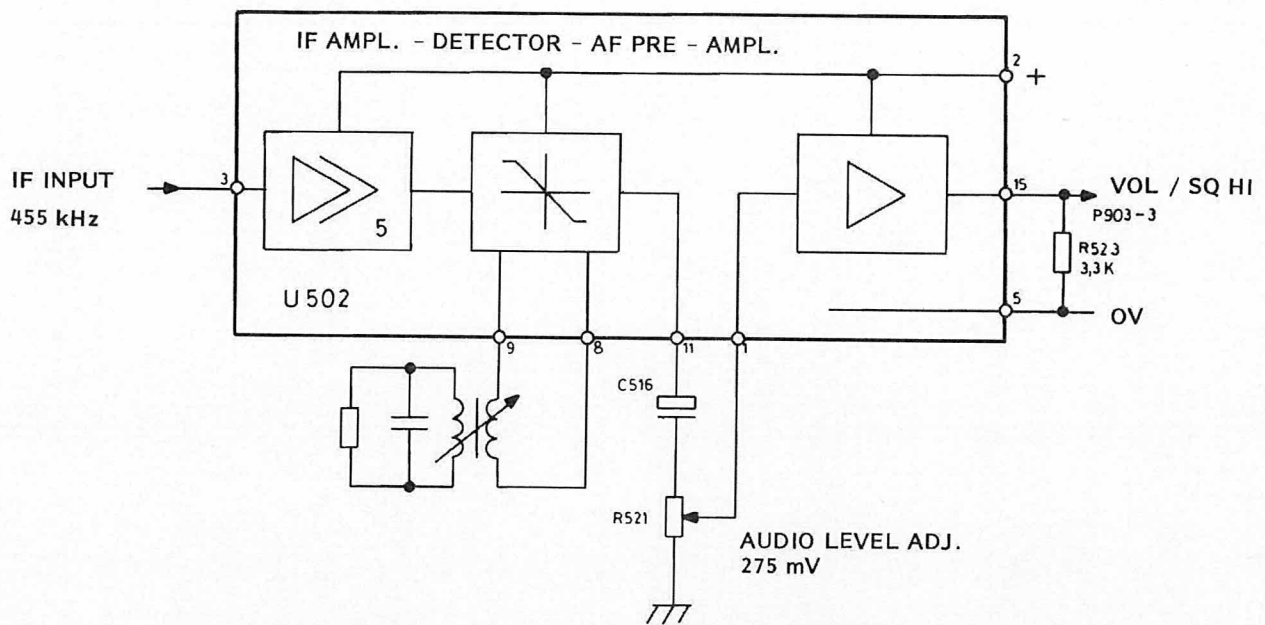

FIG. 2. IF AMPLIFIER , DETECTOR , AND AF PREAMPLIFIER

thic IC package capable of driving the loudspeaker at the desired power level. The output amplifier can be muted with a DC signal from the audio mute gate, which combines different logic signals to decide whether the amplifier should be active or not. These inputs are:

- Regulated TX Voltage
- Squelch cancel
- Squelch signal

In sets equipped with Pilot tone and/or 5-tone sequential option, an RX mute function is routed from the option board to make the extra mute conditions possible. The value of C610 in the feed back loop is chosen as the best compromise between battery ripple rejection and receiver squelch attack time.

The pilot lamp in the channel knob is supplied from A+, but controlled by the regulated 8.5 V via transistor Q968.

TRANSMITTER

The transmitter consists of a modulation processor, an exciter, and a power amplifier, all assembled on the RF board along with the receiver.

The exciter contains, an audio processor, all frequency multiplier functions, and includes those stages operating at low enough power levels to avoid heat sinks. The exciter output is at the carrier frequency when applied to the power amplifier. The power amplifier

boosts the signal to the proper level, and includes a low pass filter for suppressing harmonics and a circuitry which permits adjustment of the operating power level. The PA low pass filter connects to the antenna relay via a stripline on the board.

MODULATION PROCESSOR

The signal from the microphone load R901 on the FS board is applied to amplifier U101b.

The transmitter audio frequency response is shaped by the feedback network R104-R103-C104.

The modulation limiting is obtained in the feedback network formed by D101, D102, R105, R106 and R107. The maximum permissible frequency deviation is set by a DEV. BAL. potentiometer on the FS board.

Amplifier U101A is operated as an active low-pass splatter filter feeding the modulating input of the VCO on the Frequency Synthesizer board.

EXCITER

The exciter takes the synthesized signal, filters it to reduce spurious signals and amplifies it. Four amplifier stages (Q201-2-3-4) and four filters (L204-5-8-9) are used in a narrow band design which limits the maximum frequency spread of the transmitter. The exciter has three test points (TP201-2-3) for measurements and alignment.

POWER AMPLIFIER

The PA is constructed on the main board and employs two broadband untuned amplifier stages Q205, Q206. Two amplifier configurations are available providing options of power levels of 10 watts or 25 watts. A power control circuit is included to sense the output RF level and keep it constant with variations in temperature and supply voltage. This circuit also limits the peak power to less than maximum, as specified by the authorities, while still maintaining the output as near maximum as possible. The output power level can be set with a potentiometer, R215, over at least a 3:1 range. The transmitter delivers rated power into a 50-ohm load. A load SWR of 1.4:1 will result in more than 90% of the power being radiated. The transmitter will operate into a load with up to 3:1 SWR.

The power adjustment is achieved by controlling the supply voltage of power amplifier Q205 via transistor Q207. This series transistor is biased by a voltage generated by the feedback network C255, D201, Q201, Q209, Q208.

FREQUENCY SYNTHESIZER AND CONTROL LOGIC

The frequency synthesizer FS5551 provides up to 99 channels and is built on a printed wiring board which mounts in the top section of the radioset.

The frequency of the synthesizer board is set by a binary code from the control logic board CL5001 which is placed over the main section of the synthesizer board.

The Frequency Synthesizer board also carries all interconnections between the tone modules and the RF module, and it has two connectors at the rear for accessories and the power supply cable.

SUPPLY VOLTAGE DISTRIBUTION SYSTEM

The battery voltage (A + BATT) enters the radio via two pins of the rear system connector to the synthesizer board. Both inputs are connected to reverse polarity protection diodes D741, D742. The ground lead comes through the same connector and is connected to chassis ground through a fusible printed wiring path which will open in case of the ground wire being accidentally connected to A +.

One battery input goes directly from the synthesizer board via a feed-through capacitor and a connector P907 to the transmitter PA stages. The other input feeds through P903 - J903 to the RF board for two functions. One branch for the audio amplifier passes through an RC-ripple filter R638 - C618 and one of the ON/OFF switch sections S602. The other

section of the ON/OFF switch controls the V_B + to the voltage regulator U602 consisting of a monolithic regulator. The regulator output is fixed at 8.5 V by means of a factory adjusted resistor.

Regulated 8.5 V is switched to either the receiver or the transmitter by the antenna relay. The antenna relay is also supplied by the 8.5 V regulated.

The squelch circuit, the modulation processor, parts of the IF amplifier U502, and the Frequency Synthesizer is supplied directly from the continuous 8.5 V.

The receiver front-end, the 21.4 MHz IF sta-

ges and the second oscillator are supplied from 8.5 V RX. The transmitter exciter is supplied from 8.5 V TX.

In sets with 5-tone sequential option or Pilot tone, the PTT (Push to talk) lead runs through the option board to provide for correct tone keying function.

WARNING

The transmitter PA transistors contain Beryllia which is poisonous when absorbed by the human body. Dissection, filing, or grinding of these transistor may be hazardous.

FUNCTIONAL BLOCK DIAGRAM
CQM5550 S99

D403.186

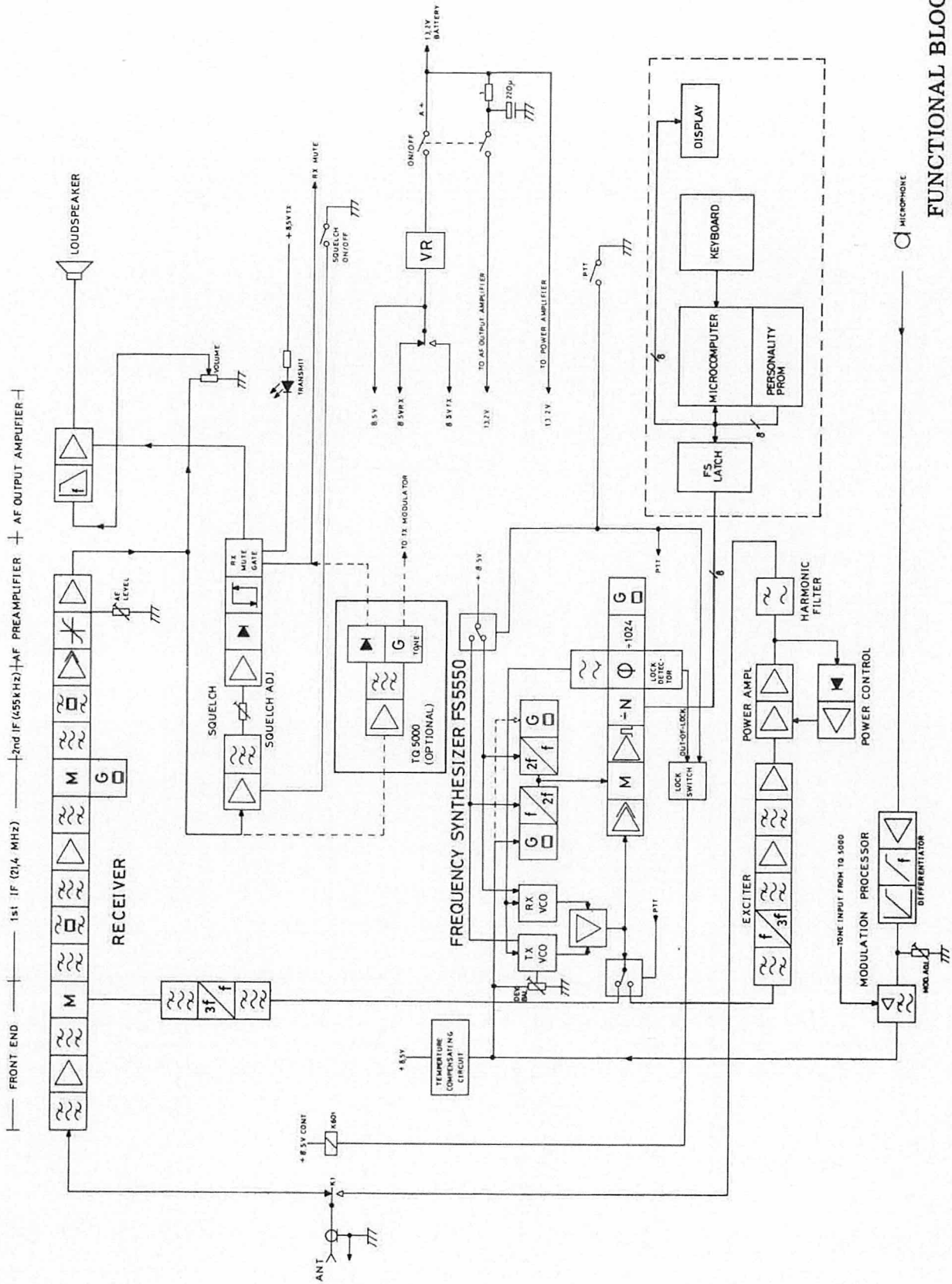

CHANNEL PROGRAMMING INSTRUCTIONS

CQM5550 S99

Programming of the PROM which contains the personality data will normally be part of the factory process, but it may also be field programmed.

The PROM programming unit must be approved by the PROM manufacturer, as for example (DATA I/O SYSTEM 19).

The programmer consists of the following items:

Programmer (DATA I/O SYSTEM 19)

Programming Pak, interchangeable

Socket adaptor

or universal programming pack.

DATA I/O UNIPAK (adaptable for more than 200 types of PROM devices).

To program a PROM the channel frequencies for all allocated channels and the channel spacing must be known.

It is recommended to complete a worksheet when calculating the prom data.

It is also possible to use a computer to calculate the prom data and Storno will be able to supply software programs for certain types of computers.

Operating instructions for the Programmer is supplied by the vendor.

WORKSHEET

For each PROM to be programmed a worksheet should be completed to calculate the input data for each channel.

The procedure for completing the worksheet is:

1. Complete list of receiver channel frequencies. (A).
2. Complete list of transmitter channel frequencies. (B).
3. Find highest (H) and lowest (L) receiving frequencies.
4. Find highest (H) and lowest (L) transmitting frequencies.
5. Select receiver mixer crystal frequency (C) from table 1. The highest and lowest receiver frequencies must be within the selected band.
6. Select transmitter mixer crystal frequency (D) from table 2. The highest and lowest transmitter frequencies must be within the selected band.
7. Note channel spacing and Reference frequency (F). See worksheet.
8. Use receiver formula to calculate " V_{DEC} " (divisor) for all receiver channels.
9. Use transmitter formula to calculate " V_{DEC} " (divisor) for all transmitter channels.
10. Check " V_{DEC} " for all channels to be between 256 and 511.
11. Use receiver crystal frequency and V_{DEC} to check for selfquieting frequencies, table 3.
12. In case of selfquieting select appropriate alternative and possibly recalculate "V".
13. Convert all " V_{DEC} " numbers to hexadecimal code. Refer to tabel 4.
14. Assign the hexadecimal codes to the corresponding channels and the PROM adresses.

After completing the worksheet, enter correct Prom addresses and corresponding data (V_{HEX}) on the Programmer (DATA I/O), refer to Programmer Operating Instructions.

RECOMMENDED CRYSTAL FREQUENCIES

CQM5550 S99

CQM5552 FREQUENCY RANGE	CQM5553 FREQUENCY RANGE	RX CRYSTAL MHz
368.9 - 375.275	367.62 - 372.72	56.85
371.4 - 377.775	370.12 - 375.22	57.266666
373.9 - 380.275	372.62 - 377.72	57.683333
376.4 - 382.775	375.12 - 380.22	58.1
378.9 - 385.275	377.62 - 382.72	58.516666
381.4 - 387.775	380.12 - 385.22	58.933333
383.9 - 390.275	382.62 - 387.72	59.35
386.4 - 392.775	385.12 - 398.22	59.766666
388.9 - 395.275	387.62 - 392.72	60.183333
391.4 - 397.775	390.12 - 395.22	60.6
393.9 - 400.275	392.62 - 397.72	61.016666
396.4 - 402.775	395.12 - 400.22	61.433333
398.9 - 405.275	397.62 - 402.72	61.85
401.4 - 407.775	400.12 - 405.22	62.26666
403.9 - 410.275	402.62 - 407.72	62.683333
406.4 - 412.775	405.12 - 410.22	63.1
408.9 - 415.275	407.62 - 412.72	63.516666
411.4 - 417.775	410.12 - 415.22	63.933333
413.9 - 420.275	412.62 - 417.72	64.35
416.4 - 422.775	415.12 - 420.22	64.76666
418.9 - 425.275	417.62 - 422.72	65.183333
421.4 - 427.775	420.12 - 425.22	65.6

TABLE 1. RECEIVER MIXER CRYSTAL FREQUENCY

RECOMMENDED CRYSTAL FREQUENCIES

CQM5550 S99

CQM5552 FREQUENCY RANGE	CQM5553 FREQUENCY RANGE	TX CRYSTAL MHz
370. - 376.375	368.72 - 373.82	60.6
372.5 - 378.875	371.22 - 376.32	61.016666
375. - 381.375	373.72 - 378.82	61.433333
377.5 - 383.875	376.22 - 381.32	61.85
380. - 386.375	378.72 - 383.82	62.266666
382.5 - 388.875	381.22 - 386.32	62.683333
385. - 391.375	383.72 - 388.82	63.1
387.5 - 393.875	386.22 - 391.32	63.516666
390. - 396.375	388.72 - 393.82	63.933333
392.5 - 398.875	391.22 - 396.32	64.35
395. - 401.375	393.72 - 398.82	64.766666
397.5 - 403.875	396.22 - 401.32	65.183333
400. - 406.375	398.72 - 403.82	65.6
402.5 - 408.875	401.22 - 406.32	66.016666
405. - 411.375	403.72 - 408.82	66.433333
407.5 - 413.875	406.22 - 411.32	66.85
410. - 416.375	408.72 - 413.82	67.266666
412.5 - 418.875	411.22 - 416.32	67.683333
415. - 421.375	413.72 - 418.82	68.1
417.5 - 423.875	416.22 - 421.32	68.516666
420. - 426.375	418.72 - 423.82	68.933333
	421.22 - 426.32	69.35

TABLE 2. TRANSMITTER MIXER CRYSTAL FREQUENCY

SELFQUIETING FREQUENCIES

CQM5552 S99

RECEIVER CRYSTAL FREQUENCY MHz	V DEC	USE ALTERNATIVE ⁺
56.850	321	4
56.850	366	4
60.183	404	2
60.600	304	2
63.100	384	4
63.516	469	4
63.933	369	4
63.933	415	4
63.933	424	4
64.350	269	4
64.350	278	4
64.350	324	4
64.350	428	4
64.766	428	4
65.183	428	4
65.600	428	4

TABLE 3A. SELFQUIETING FREQUENCIES

⁺ refer to worksheet

SELFQUIETING FREQUENCIES

CQM5553 S99

RECEIVER CRYSTAL FREQUENCY, MHz	V DEC	USE ALTERNATIVE [†]
56.850	458	4
60.183	505	4
60.600	380	4
60.600	426	4
61.016	301	4
61.850	375	4
63.933	473	4
64.350	348	4
64.350	394	4
64.350	405	4
64.766	269	4
64.766	280	4

TABLE 3B. SELFQUIETING FREQUENCIES

[†] refer to worksheet

HEX CODE CONVERSION TABLE

		Least Significant Digit (LSD) of Hex Code															
		0	1	2	3	4	5	6	7	8	9	A	B	C	D	E	F
Most Significant Digit of Hex Code.	0	256	257	258	259	260	261	262	263	264	265	266	267	268	269	270	271
	1	272	273	274	275	276	277	278	279	280	281	282	283	284	285	286	287
	2	288	289	290	291	292	293	294	295	296	297	298	299	300	301	302	303
	3	304	305	306	307	308	309	310	311	312	313	314	315	316	317	318	319
	4	320	321	322	323	324	325	326	327	328	329	330	331	332	333	334	335
	5	336	337	338	339	340	341	342	343	344	345	346	347	348	349	350	351
	6	352	353	354	355	356	357	358	359	360	361	362	363	364	365	366	367
	7	368	369	370	371	372	373	374	375	376	377	378	379	380	381	382	383
	8	384	385	386	387	388	389	390	391	392	393	394	395	396	397	398	399
	9	400	401	402	403	404	405	406	407	408	409	410	411	412	413	414	415
	A	416	417	418	419	420	421	422	423	424	425	426	427	428	429	430	431
	B	432	433	434	435	436	437	438	439	440	441	442	443	444	445	446	447
	C	448	449	450	451	452	453	454	455	456	457	458	459	460	461	462	463
	D	464	465	466	467	468	469	470	471	472	473	474	475	476	477	478	479
	E	480	481	482	483	484	485	486	487	488	489	490	491	492	493	494	495
	F	496	497	498	499	500	501	502	503	504	505	506	507	508	509	510	511

"V_{DEC}" Numbers.

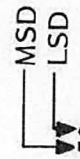

Example "V_{DEC}" = 345 equals to hex code 59.
 "V_{DEC}" = 469 equals to hex code D5.

Table 4.
 "V" Number to hex code conversion table.

PROGRAMMING WORKSHEET

FOR CQM5550 S99

Customer: _____

RECEIVER						TRANSMITTER					
CHAN- NEL	A FREQUENCY MHz	L H	V DEC	V HEX	PROM ADDRESS (HEX)	B FREQUENCY MHz	L H	V DEC	V HEX	PROM ADDRESS (HEX)	
1											
2											
3											
4											
5											
6											
7											
8											
9											
10											
11											
12											

RECEIVER MIXER CRYSTAL FREQ. (Y702): C= _____

FORMULA: $V_{DEC} = \frac{(A - 21.4) - (C \times 6)}{3 \times F}$

TRANSMITTER MIXER CRYSTAL FREQ. (Y701) D= _____

FORMULA: $V_{DEC} = \frac{B - (D \times 6)}{3 \times F}$

CHANNEL SPACING:	REFERENCE CRYSTAL (Y703):	REFERENCE FREQUENCY:
20 kHz	6. 8263 MHz	F= 0.006666
25 kHz	8. 5333 MHz	F= 0.008333

LIST OF REFERENCE CRYSTALS (Y703)

ALTERNATIVE SOLUTIONS IF THE RECEIVER IS SELFQUIETING:

MODE	FREQUENCY, MHz	PART No.
Standard 5552	8.5333333	19J706361P3
Standard 5553	6.826666	19J706361P4

1. SELECT ANOTHER RX MIXER CRYSTAL FREQUENCY
2. SELECT HIGH INJECTION FREQUENCY FOR 2nd OSCILLATOR
Y501= 21.85500 MHz INSTEAD OF 20.94500 MHz
3. USE SLIGHTLY OFFSET REFERENCE CRYSTAL
4. WEAK QUIETING; NO ALTERNATIVE REQUIRED

ADJUSTMENT PROCEDURE

CQM5550 S99

This adjustment procedure applies to the following radiotelephone types:

CQM5552 : 30/25 kHz Channel spacing

CQM5553 : 20 kHz Channel spacing

Before making adjustments to the radiotelephone transmitter/receiver, read the type label and note the channel frequencies.

Check all straps according to the notes on the diagrams. Also check the selective calling tone equipment, if any, against the coding instructions; refer to description of tone equipment.

All screens must be in place and properly secured during the adjustments.

MEASURING INSTRUMENTS

The following list contains instruments necessary for adjusting the radiotelephone and checking its performance characteristics:

DC Voltmeter	$R_{in} \geq 1$ Mohm
AC Voltmeter	$Z_{in} > 1$ Mohm//50 pF
Multimeter	$R_i \geq 20$ Kohm/Volt
Distortion meter	e.g. Storno E11c
RF Watt meter	25 W/50 ohm/370-420 MHz
Deviation meter	370-420 MHz
RF generator	$Z_{out} = 50$ ohm; 370-420 MHz
21.4 MHz signal generator	e.g. Storno TS-G21B

Frequency counter with attenuator	$Z_{in} = 50$ ohm; sensitivity 100 mV at 420 MHz
RF diode probe	Storno 95.0089-00
RF coaxial probe	Storno 95.0179-00
DC power supply	10.8 V - 16.6 V; 6A
Oscilloscope	0 - 5 MHz min.

MISCELLANEOUS

4 ohm/3 W resistor	3 x Storno code 82.5026-00
22 uF/40 V electrolytic capacitor	Storno code 73.5107-00
Connector, 11-pin house	Storno code 41.5543-00
Connector, 8-pin house	Storno code 41.5542-00
Pins for connectors	Storno code 41.5551-00
Trimming tools	

The following tables show the frequency ranges of the CQM5550 S12 radiotelephone signals:

SIGNAL	FREQUENCY MHz
TX VCO	123 - 140
TX crystal	60 - 69
TX crystal multiplication	x2
RX VCO	116 - 132
RX crystal	56 - 65
RX crystal multiplication	x2

Table 1.

Channel spacing kHz	Reference Crystal MHz	Min. Divider input frequency MHz	Max. Divider input frequency MHz	Reference frequency kHz
20	6.8263	1.7066	3.4066	6.666
30 or 25 ¹⁾	8.5333	2.1333	4.2583	8.333

Table 2

¹⁾ Two steps per channel

RECEIVER TEST SET-UP

CQM5550 S99

D403.032/2

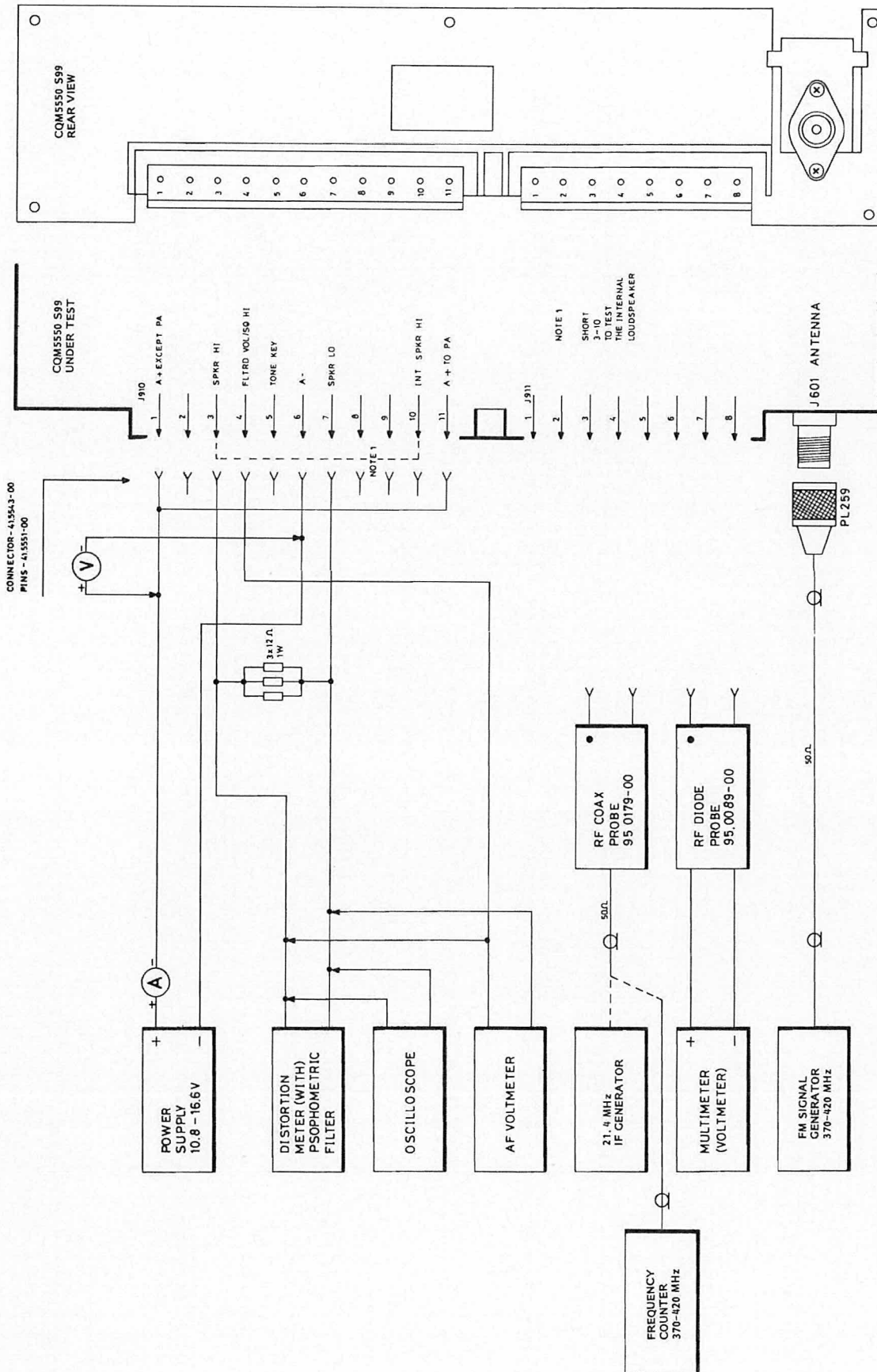

RECEIVER ADJUSTMENT

CHECKING 8.5 V REGULATED SUPPLY

Turn the power supply ON and set the voltage to 13.2 V. Set the power supply current limiter to 1 A.

Turn the radiotelephone ON by depressing the ON/OFF button. Note the light in the Channel selector, if any, is on.

Depress the Squelch button.

Set the volume control to minimum.

Connect the DC voltmeter to J901 pin 3 and read the Voltage.

Requirement: 8.5 V \pm 0.15 V

If the requirement is not fulfilled check resistor R636 against the colour code of U602.

U602 colour code R636 ohm

Brown	omit
Red	270
Orange	100
Yellow	47
Green	22
Blue	6.8

Adjust the power supply voltage to 16.6 V and read the 8.5 V regulated. Compare the change in the 8.5 Volt regulated to the value obtained at 13.2 V.

Requirement: \leq 50 mV

Repeat the procedure with the power supply adjusted for 10.8 V

FREQUENCY SYNTHESIZER ALIGNMENT

Check the PROM U801, the TX mixer crystal, the RX mixer crystal, and the reference crystal and verify the frequencies and PROM codes.

Mixer crystal output

Connect RF diode probe 95.0089-00 with multimeter to test point TP701. (1 V range).

Adjust L711 for maximum deflection on the multimeter.

Adjust L707 for maximum deflection on the multimeter.

Requirement: 45 mV \pm 15 mV
(corresponding to -10 dBm to -4 dBm).

Note: Be careful not to resonate L707 to the false harmonics. If in doubt consult table 1 or check the crystal oscillator output with a spectrum analyzer.

Receiver VCO

Connect the multimeter, 10 V range, to test point TP706. The synthesizer's lock signal is accessible at TP706. +8 V DC with very narrow pulses (0.1 μ sec) indicates normal locked condition. Unlocked condition is indicated by a variable duty signal or logic "Low". Select the channel whose frequency is closest to the center frequency.

Await locked condition, constant voltage.

Adjust C745 for 8 Volts on the multimeter.

Connect the multimeter to test point TP703.

Adjust C745 for a voltage corresponding to the variable divider ratio (V) as indicated by the graph fig. 3.

Requirement: The voltage shall be in the range 1.5 V to 6.5 V and not deviate from the graph by more than 20%.

Mixer Crystal Frequency

Connect coax probe 95.0179-00 to test point TP701.

Connect the frequency counter to the probe and read the frequency.

$f = f_x \times 2$ (f_x = crystal frequency)

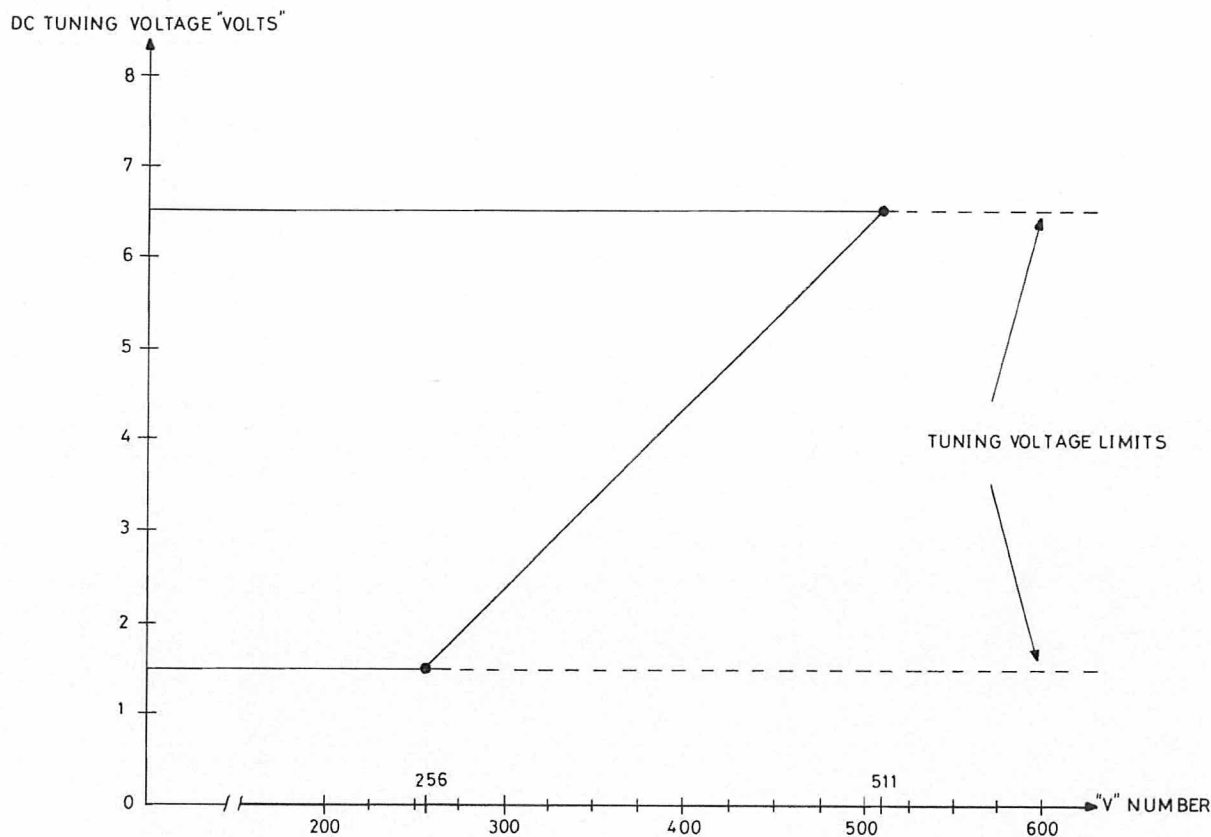

Fig. 1. Tuning voltage vs. V. number.

Adjust L711 to the calculated frequency.

Requirement: $f \pm 0.3$ ppm at 25°C .

ppm= parts per million= 10^{-6}

Injection Frequency

Connect coax probe 95.0179-00 to test point TP401.

Connect the frequency counter to the probe.

Calculate the injection frequency for all channels.

$$f_{inj} = f_{ant} - 21.4 \text{ MHz}$$

Select, one by one, the channels and read the injection frequency.

Requirement: $F_{inj} \pm 0.2$ ppm

IF AMPLIFIERS

Connect a 21.4 MHz signal generator to TP401 via coax probe 95.0179-00.

Connect RF diode probe 95.0089-00 with multimeter to test point TP501. (50 μA range).

During adjustment the RF generator output must be kept low enough to prevent limiting

in the IF stages, i. e. a maximum reading of 50 μA on the multimeter.

Adjust coils L503, L502, L501, and L406, in that order, for maximum deflection on the multimeter.

FRONT-END

Connect the RF probe 95.0089-00 and the multimeter to test point TP501. (50 μA range).

Connect an unmodulated RF generator to the antenna connector, J601.

Set the generator frequency to the receiver frequency.

Adjust the generator output to produce a deflection on the multimeter, i. e. a maximum reading of 50 μA on the multimeter.

Adjust L401 and L402 for maximum deflection. Detune L406. Adjust L405 and L407 for maximum deflection on the multimeter.

Adjust L406 for maximum deflection.

Readjust L401 and L402 for maximum deflection.

Remove the RF diode probe.

Standard Test condition:

Connect the RF generator to antenna connector and adjust the output to 1 mV e. m. f. Modulate the RF generator with 1000 Hz to 60% of Δf max.

CQM5552 S12/S99 ± 3 kHz
CQM5553 S12/S99 ± 2.4 kHz

Connect a 4 ohm/3 W resistor load to connector J910/3-7 (SPKR HI-SPKR LO). Connect an AF voltmeter to J910/4-7 (FLTD VOL SPKR LO).

IF DEMODULATOR

Turn R521 halfway up.
Adjust L504 for maximum reading on the AF voltmeter.

Connect a distortion meter and AF voltmeter across the 4 ohm resistor. (if Storno E11c distortion meter is used switch the function to AF voltmeter).

Adjust the volume control for approx. 2 V across the load.

Adjust L501 and L406 for minimum distortion. The demodulated signal may be monitored on an oscilloscope connected in parallel with the distortion meter.

Connect the AF voltmeter and distortion meter to J910/4-7 (FLTD VOL - SPKR LO).

Adjust R521 for a reading of 275 mV on the AF voltmeter.

Requirement: 275 mV ± 5 mV.

Read the distortion.

Typical Total Harmonic Distortion (THD) will be less than 5%.

RECEIVER SENSITIVITY

EIA or CEPT method may be used.

Method of measurement CEPT

The purpose of the measurement is to define

the ratio of one condition to another.

The first condition is the one where a modulated RF-signal drives the receiver into full limiting. The audio output is measured with the distortion meter (in the CAL position) and, disregarding the amplitude of the audio, this is adjusted to read 100% on the meter scale; this is our reference condition consisting of signal +noise +distortion, where 'signal' is the modulation of the RF, 'noise' is the lowest possible amount achieved from that particular receiver, when receiving a strong carrier, and 'distortion' is the modulation being slightly distorted in passing through the receiver.

The second condition is the one where the signal (modulation) is removed with a notch filter and the RF-signal is lowered in amplitude until the remaining noise and distortion increases to 20 dB below the first condition, as read on the distortion meter scale. This corresponds to a reading of 10%, 10 being 20 dB below 100, which was our reference condition.

In practice our first condition is achieved by feeding a minimum of 1000 μ V of RF-signal modulated with 1000 Hz at 60% Δf max. to the receiver.

The audio output (which must be at least 100% of the receiver's audio rating) is measured through the psophometric filter, with the distortion meter in position CAL and adjusted with potentiometer ADJ. FSD. to a reading of 100.

The notch filter is then inserted in series with the audio by pressing one of the buttons marked in %. The meter needle immediately drops to indicate a low value, this being the receiver's inherent audio distortion.

By backing off the attenuator of the RF generator, thereby lowering the RF input to the receiver, the noise will eventually increase; the attenuator is now adjusted for a 10% reading on the distortion meter scale.

At this stage it must be ensured that the increased noise and the signal (with the notch filter switched out while checking) still equals 100 on the meter scale.

The RF-generator's calibrated attenuator now shows the value of RF-signal required to achieve a 20 dB ratio between signal + noise + distortion and noise + distortion, i. e. 20 dB SINAD sensitivity.

EIA Method

EIA (Electronic Industries Association)

Standard, definition:

The SINAD sensitivity of a receiver is the minimum input signal that will provide at least 50% of the receivers's rated audio power with 12 dB signal + noise + distortion to noise + distortion.

The EIA method differs from CEPT by omitting the psophometric filter, adjusting the RF generator for $2/3 \times \Delta f_{max.}$, and measure the distortion at 50% of the receiver's rated AF power. The SINAD sensitivity is measured as a 12 dB ratio between signal + noise + distortion and noise + distortion, which corresponds to a reading of 25% noise + distortion.

ADJUSTING THE SENSITIVITY

Lower the RF generator output to obtain 20 dB SINAD (10% THD as measured with the distortion meter). Readjust L402 for the best SINAD value, e. i. lowest generator output for 10% THD.

MEASURING 20 dB SINAD (CEPT)

Adjust the volume control for 2.45 V (1.5 W/4 ohm) as measured with an AF voltmeter across the load.

Adjust the RF generator output to obtain 20 dB SINAD condition.

Read the 20 dB SINAD sensitivity (e. m. f.)

Requirement: ≤ 1.0 uV.

The sensitivity should be measured on all channels, if more than one.

MEASURING 12 dB SINAD (EIA)

Adjust the volume control for 2.45 V as measured with an AF voltmeter across the load.

Adjust the RF generator to obtain 12 dB SINAD condition.

Read the 12 dB SINAD sensitivity.

Requirement: ≤ 0.4 uV ($\frac{1}{2}$ e. m. f.)

The sensitivity should be measured on all channels, if more than one.

AUDIO FREQUENCY RESPONSE

Set the signal generator to Standard Test Condition.

Adjust the volume control for 0.82 V across the load. (4 ohm across (SPKR HI - LO)).

At 13.2 V supply, $\Delta F = 60\%$ ΔF max and 1000 Hz measure the output voltage according to the following table:

	Frequency	Level	Tol.
CQM5552 S12/S99	300 Hz	+9 dB	+1 dB/-3 dB
	1000 Hz	0 dB	
	3000 Hz	-9.5 dB	+1 dB/-3 dB
CQM5553 S12/S99	300 Hz	+10.5 dB	+1.5 dB/-3 dB
	400 Hz	+8 dB	+1.5 dB/-1.5 dB
	1000 Hz	0 dB	
	2700 Hz	-8.6 dB	+1.5 dB/-1.5 dB
	3000 Hz	-9.5 dB	+1.5 dB/-3 dB
	6000 Hz	<-20 dB	

SELF QUIETING CHECK

Internal oscillators, dividers and the harmonic frequencies hereof, may cause self quieting of the receiver if a mixer product falls in the RF or IF pass band.

For proper operation of the squelch all channels must be checked for the self quieting phenomenon.

Connect the RF generator to the antenna connector. Reduce the RF output to 0.

Set the frequency outside the 420 - 470 MHz band.

Alternatively, an attenuator (50 ohm) may be connected to the antenna connector.

Connect an AF voltmeter across the 4 ohm speaker load.

Adjust the volume control for 774 mV (0 dBm) as read on the AF voltmeter.

Select, in turn, all allocated channels.

The reading on the AF voltmeter shall not on any selected channel decline more than 6 dB.

Requirement: Quieting ≤ 6 dB.

AF POWER OUTPUT

Adjust the RF signal generator to Standard Test Condition.

Set the supply voltage to 13.2 V.

Adjust the volume control for 3 W output (3.46 V across the 4 ohm load).

Measure the distortion (THD).

Requirement: THD $\leq 5\%$.

SQUELCH

Release the squelch cancel button.

Adjust potentiometer R607 squelch adj. to open the receiver for an RF input signal corresponding to 8-10 dB SINAD.

The final squelch adjustment must not be set on a channel that has shown a minor degree of selfquieting.

CURRENT CONSUMPTION

Measure the current consumption at 13.2 V.

Requirements

CURRENT CONSUMPTION

CONDITION	S12	S99
Standby	≤ 350 mA	≤ 1000 mA
Receive 2 W AF ~ 2.83 V r. m. s. across 4 ohm.	≤ 750 mA	≤ 1450 mA

For sets with selective calling facilities add current consumption of the tone unit to the figures above.

TRANSMITTER ADJUSTMENT

Adjust the power supply voltage to 13.2 V and set current limiter as follows:

20 W transmitter:	7 A
5 W transmitter:	4 A

Refer to Receiver Alignment for measuring 8.5 V regulated supply.

Preset all transmitter tuning slugs, L151,

L153, L201, L202, L204, and L205 to be flush with the coil form top.

Connect a multimeter (2.5 volt range) to test point TP201.

Turn the power control potentiometer, R221, to minimum, anticlockwise (CCW).

Connect a Wattmeter, (25 W) to the antenna connector, J601.

FREQUENCY SYNTHESIZER ALIGNMENT

Check the PROM U801, the TX mixer crystal, the RX mixer crystal, and the reference crystal and verify the frequencies and the prom codes.

Mixer crystal output

Connect RF probe 95.0089-00 with multimeter to test point TP701 (1 V range).

Key the transmitter.

Adjust L701 for maximum deflection on the multimeter.

Adjust L704 for maximum deflection on the multimeter.

Requirement:

40 mV \pm 15 mV

(corresponding to -10 dBm to -4 dBm)

Note: Be careful not to resonate L704 to the false harmonics. If in doubt consult table 1 or check the crystal oscillator output with a spectrum analyzer.

Transmitter VCO

Connect the multimeter, 10 V range, to test point TP706.

The synthesizer's lock signal is accessible at TP706 and +8 V DC with very narrow pulses (0.1 μ sec.) indicate normal locked condition. Unlocked condition is indicated by a variable duty signal or logic "LOW".

Select the channel whose frequency is closest to the center frequency. Key the transmitter. Await locked condition.

Adjust C737 for 8 Volts on the multimeter.

Connect the voltmeter to test point TP703.

Adjust C737 for a voltage corresponding to the variable divider ratio (V) as indicated by the graph fig. 3.

Requirement: The voltage shall be in the range 1.5 V to 6.5 V and not deviate from the graph by more than 20%.

Mixer Crystal Frequency

Connect coax probe 95.0179-00 to test point TP702.

Connect the frequency counter to the probe, key the transmitter and read the frequency. $f = f_x \times 2$ (f_x = crystal frequency).

Adjust L701 to the calculated frequency.

Requirement: $f \pm 0.3$ ppm at 25°C.

ppm = parts per million = 10^{-6} .

Synthesizer Output Level

Connect a multimeter, 2.5 V range, to test point TP201. Key the transmitter.

Adjust L153 for maximum deflection on the multimeter, typical more than 0.75 V.

EXCITER, COARSE ADJUSTMENT

Connect a multimeter (1.0 V range) to test point TP201.

Adjust L203 for minimum deflection. The dip is small.

Connect the multimeter, (1 V range) to test point TP202.

Adjust L204 for maximum deflection on the multimeter, typical 0.9 V.

Repeat the adjustments of L203, L153, and L151 (L921-L926) until no further improvements is obtainable.

Adjust C213 for minimum reading. The dip is small.

Connect the multimeter, 1 volt range, to test point TP203.

Adjust C215 for maximum reading on the multimeter, typical 0.5 V.

Repeat the adjustment of C213 and L204 until no further improvement is obtainable.

Adjust C221 to minimum deflection. The dip is small and careful tuning is required.

Connect the multimeter, 10 volt range, to the RF probe.

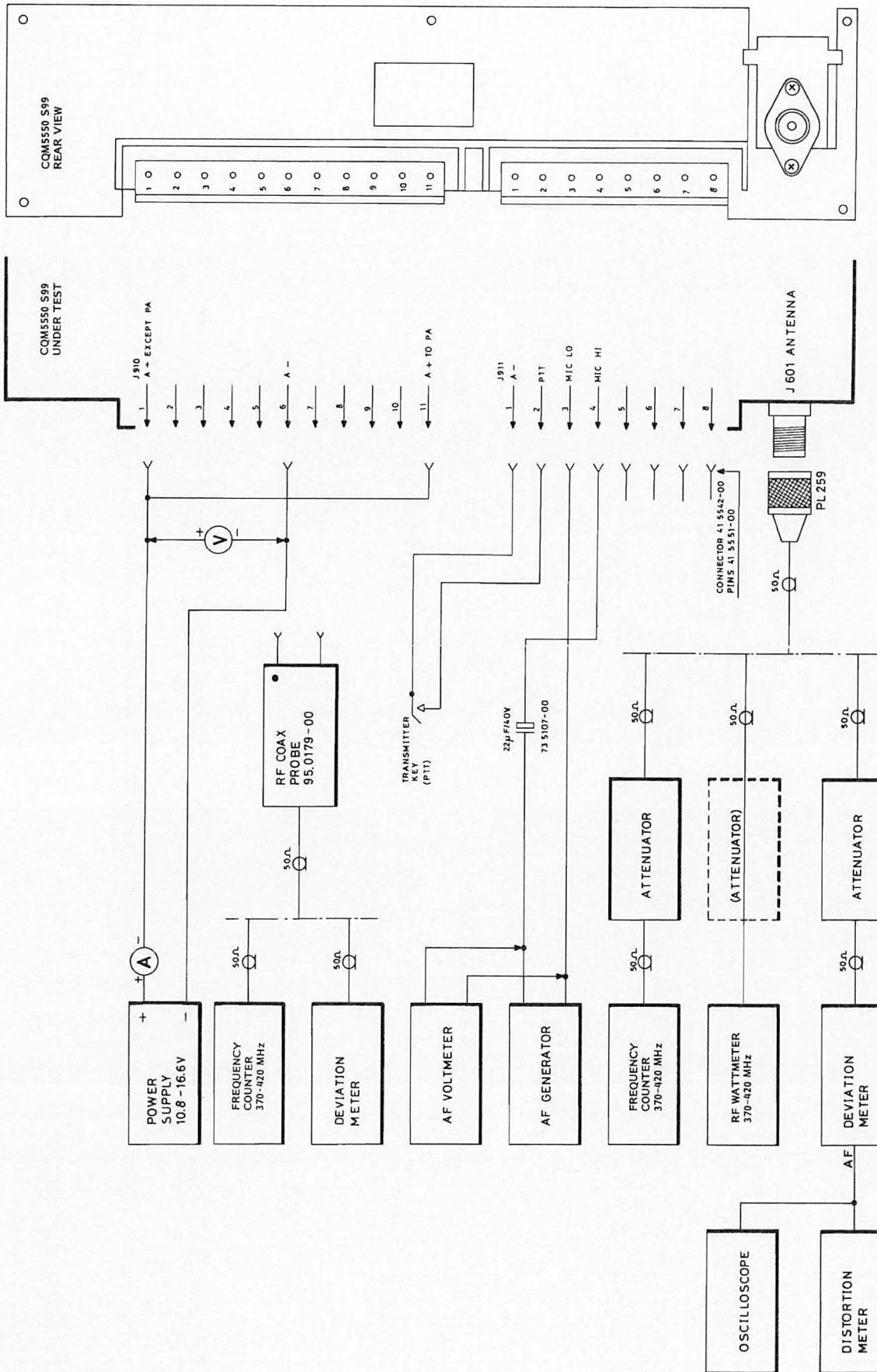

TRANSMITTER TEST SET-UP
CQM5550 S99

D403.033/2

Connect RF diode probe 95.0089-00 to TP204.
Adjust C221 and C223 for maximum deflection (typical 4.0 V).

Adjust the PA power control, R215, for rated transmitter power, 5 W or 20 W.

Adjust L701 for best frequency tracking on all channels.

Requirement: $F = F_{\text{ant}} \pm 0.2 \text{ ppm}$,
ppm = parts per million = 10^{-6}

EXCITER, FINE ADJUSTMENT

Connect the multimeter to test point TP201.
Readjust L153 for maximum reading.
Connect the multimeter to test point TP202.
Peak L203 and L204 for maximum reading.
Connect the multimeter to test point TP203.
Peak C213 and C215 for maximum reading.
Connect the 95.0089-00 RF probe and multimeter to TP204.
Adjust C221 and C223 for maximum reading.

RF POWER OUTPUT, CURRENT CONSUMPTION, AND POWER CONTROL

Connect the Watt meter to the antenna connector, J601.
Increase the supply voltage to 13.2 V. The voltage is measured directly at the input connector J910.
Readjust the PA power control, R221, for rated transmitter power (P), 20 W or 5 W.
Requirement: $P_{\text{nom}} \pm 0.2 \text{ dB}$.
Measure the RF power output at 16 V, 13.2 V and 10.8 V.

TYPICAL TEST POINT READINGS

TP201: 0.5 V
TP202: 0.9 V
TP203: 0.5 V
TP204: 4.0 V

Requirements (20 W):

		S12	S99
Voltage	Power	Current	Current
16 V	$\leq 25 \text{ W (ref)}$	$\leq 5.4 \text{ A}$	$\leq 6.1 \text{ A}$
13.2 V	20 W	$\leq 5.4 \text{ A}$	$\leq 6.1 \text{ A}$
10.8 V	$\geq 12 \text{ W}$	$\leq 5.4 \text{ A}$	$\leq 6.1 \text{ A}$

TRANSMITTER FREQUENCY ADJUSTMENT

Connect a frequency counter through a suitable attenuator to the antenna connector J601.
Key the transmitter.
Select one by one, the channels and read their frequencies.

Requirements (5 W):

		S12	S99
Voltage	Power	Current	Current
16 V	$\leq 6.5 \text{ W (ref)}$	$\leq 1.7 \text{ A}$	$\leq 2.4 \text{ A}$
13.2 V	5 W	$\leq 1.7 \text{ A}$	$\leq 2.4 \text{ A}$
10.8 V	$\geq 3.5 \text{ W}$	$\leq 1.7 \text{ A}$	$\leq 2.4 \text{ A}$

MODULATION ADJUSTMENT

Set the power supply voltage to 13.2 V.
Select the channel having the highest frequency. Set R116 to mid-position.
Connect coax probe 95.0179-00 to test point TP701.
Connect a deviation meter to the coax probe.

Connect a distortion meter and oscilloscope to the deviation meter output.
Connect a AF generator and an AF Voltmeter to the microphone input via a 22 uF capacitor; refer to test setup.
Set the AF generator to 1000 Hz.
Adjust the AF generator output to 1 V r.m.s.

This voltage is approx. 20 dB above the nominal modulation input level (60% Δf max) to ensure full limiting in the modulation processor.

Note the deviation read at TP701.

Connect the deviation meter to test point TP702.

Adjust R752 (Dev. Bal.) for same deviation as measured at TP701.

Disconnect the deviation meter from the coax-probe and connect it through an attenuator to the antenna connector, J601.

Find the AF frequency between 200 Hz and 3000 Hz giving the greatest frequency deviation as read on the deviation meter with the transmitter keyed.

Check the maximum deviation for both positive and negative deviation polarity. At that audio frequency set the maximum frequency deviation Δf max with R116.

Type	Channel spacing	Δf max
CQM5552	30/25 kHz	± 5 kHz
CQM5553	20 kHz	± 4 kHz

Requirement

Difference between + and - deviation: ≤10%

MODULATION SENSITIVITY AND MODULATION DISTORTION

Set the AF generator frequency to 1000 Hz
Adjust the generator output until 60% of Δf max is obtained on the deviation meter.

CQM5552 : ± 3.0 kHz

CQM5553 : ± 2.4 kHz

Read the AF generator output and measure the modulation distortion on the audio output of the deviation meter.

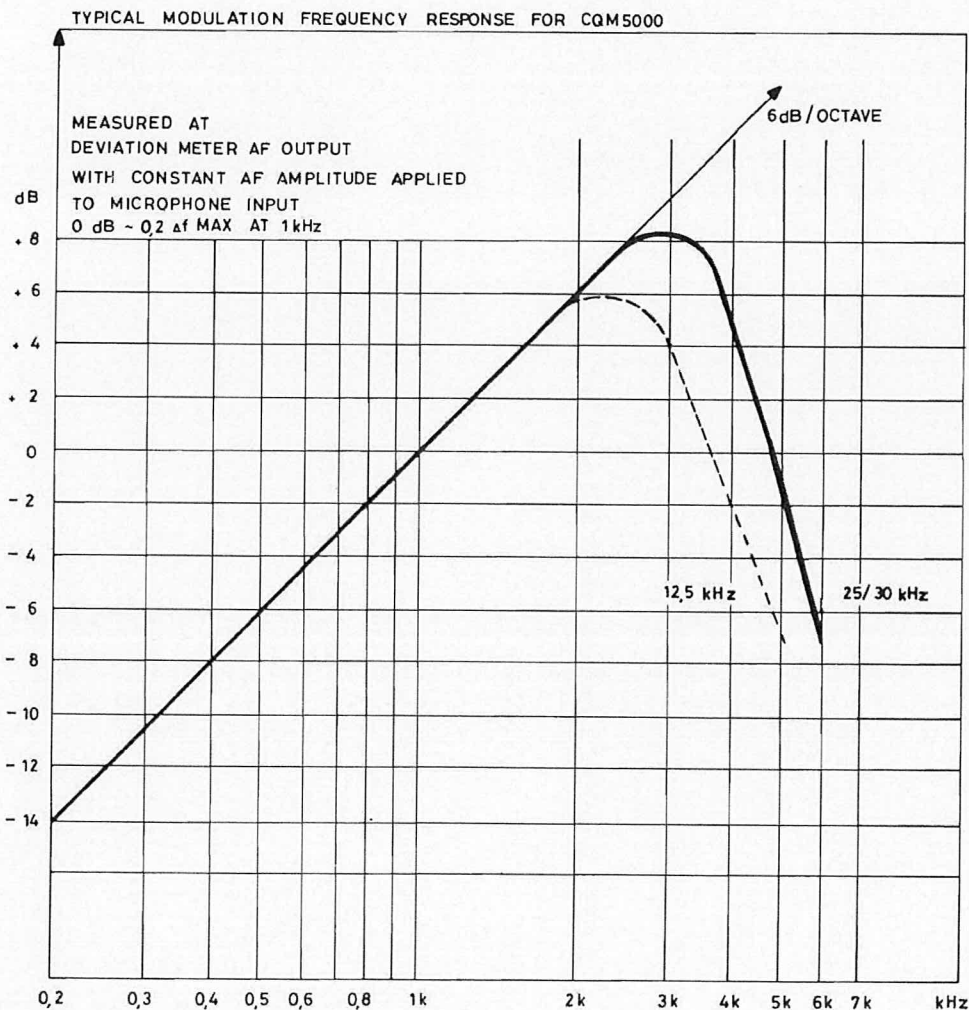

Requirements:

Modulating signal: 75 mV \pm 3 dBDistortion: \leq 7%

(measured without deemphasis)

MODULATION FREQUENCY RESPONSE

Set the AF generator to 1000 Hz.

Reduce the AF generator output until a deviation of $0.2 \times \Delta f$ max is obtained on the deviation meter.

CQM5552 : \pm 1.0 kHzCQM5553 : \pm 0.8 kHz

Vary the frequency of the generator and note the deviation changes as referred to the 1000 Hz value.

Requirement :

Within the frequency range 400-2700 Hz the frequency characteristic shall lie within +1 dB/-1.5 dB related to a 6 dB/octave characteristic.

With 6 kHz modulation frequency the deviation shall be attenuated at least 6 dB below the 1 kHz value.

CHANNEL FREQUENCY SYNTHESIZER

FS5551 and FS5552

The frequency synthesizer generates up to 12 channel frequencies for a STORNOPHONE 5000 operating in the 370 - 420 MHz band. It is built on a printed circuit board which mounts in the top section of the radio set. There are two versions of the board, a single channel board, FS5551 and a multichannel board FS5552. The frequency of the single channel board is set by putting a binary code directly on the programmable divider input while the multichannel board channels are selected with a channel selector and a Frequency Control unit, FC5001. The channel selector is mounted directly on the board and protrudes through the front panel, and the Frequency Control module FC5001, fits into the cast shield which is placed over the main section of the synthesizer board. A metal shield is placed underneath the oscillator and mixer sections of the board.

All circuitry can be accessed and operated for repair and maintenance without the shields and with the FC5001 in its socket.

The Frequency Synthesizer board also carries all interconnections between the tone modules and the RF module and has two connectors at the rear for accessories and power supply cables.

The channel programming is contained in a 256 bit PROM placed in a socket on the Frequency Control module. The PROM can be field programmed if the necessary programming equipment is available. Programming equipment and procedures must be approved by STORNO and the PROM manufacturer, refer to the Channel Programming Instructions.

CIRCUIT DESCRIPTION

The Frequency Synthesizer generates the local oscillator injection for the receiver and a modulated exciter signal for the transmitter. The circuit is a single-loop phase-locked frequency generator.

The synthesizer frequency is controlled by three crystals, one reference crystal and two mixer crystals, and by a PROM. The synthesizer can be reprogrammed for new frequencies if these are within the maximum frequency spread of the STORNOPHONE 5000.

Two voltage controlled oscillators (VCO) are generating the signals which are used as injection for the receiver mixer and excitation signal for the transmitter. The frequency of

each VCO can be preset to any frequency within the band by a variable capacitor, and the fine adjustment is controlled by a variable capacitance diode, varicap, and the phase detector output. The control voltage for the varicaps is filtered in a loop integrating filter. The TX VCO has an additional varicap which is used to modulate the transmitter.

The Push-to-talk switch controls a transistor switch, which switches the supply voltage between the RX VCO and the TX VCO.

The output signal from the VCO's are fed into a buffer amplifier which protects the VCO from load changes.

The buffer amplifier's output is applied to an

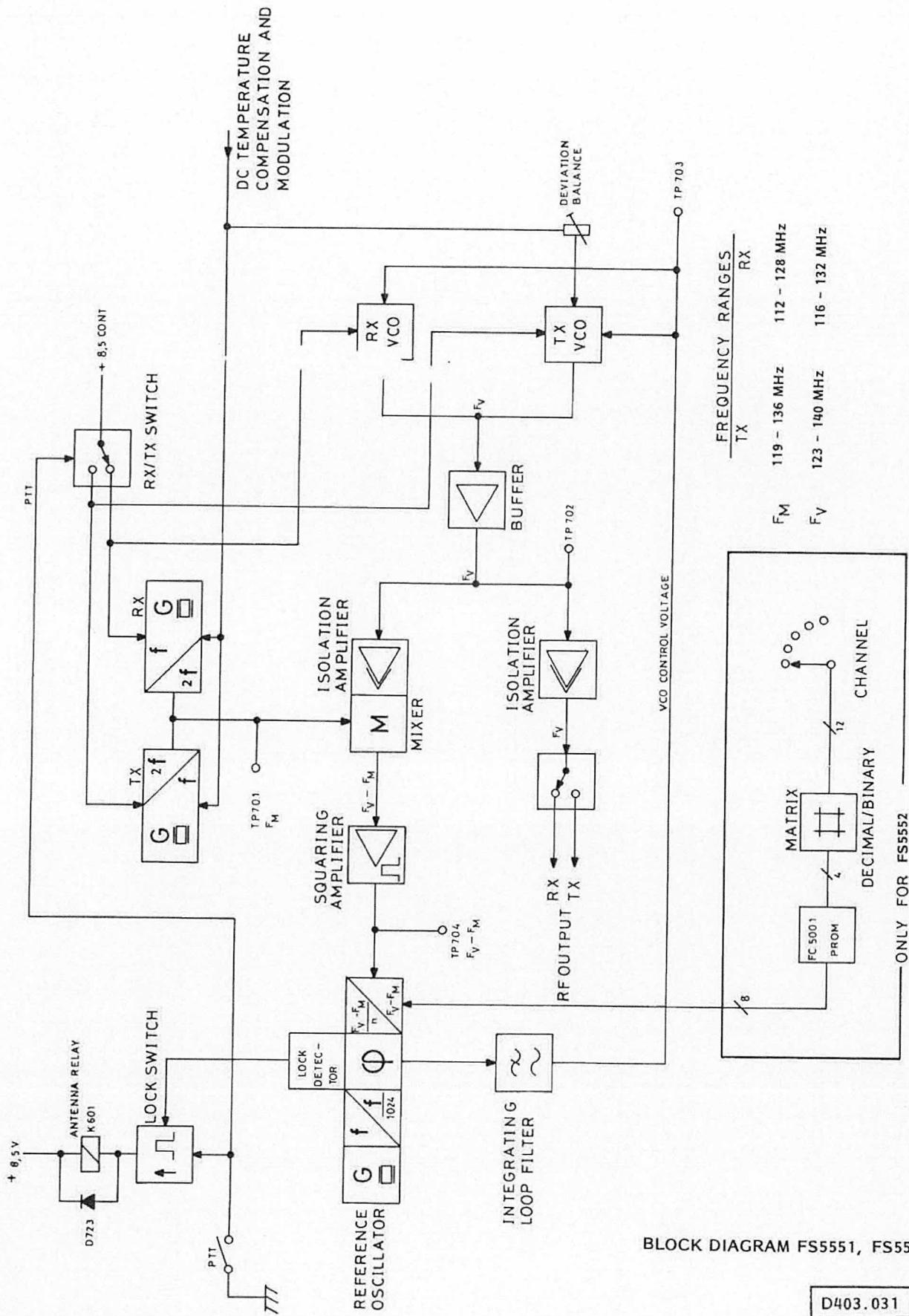

BLOCK DIAGRAM FS5551, FS5552

D403.031

isolation amplifier and a diode switch before entering the RF board.

The buffer amplifier also connects to another isolation amplifier via a resistive attenuator and feeds the signal to the synthesizer mixer.

The synthesizer mixer mixes the VCO signal and the crystal oscillator signal to a frequency which is within the dividing capability of the programmable divider.

Separate crystal oscillators are used in the receive and transmit mode, respectively, and they are both third mode oscillators.

A temperature compensating voltage is applied to the crystal oscillators only in the 5 p.p.m. version. This voltage is kept constant in the 10 p.p.m. version by cutting a diode on the RF board.

The output from the synthesizer mixer is fed to a squaring amplifier which drives the programmable divider and this divides the frequency by 256 to 511 depending on the logic levels on the 8-bit binary control input. The input frequency range for the divider differs according to the channel spacing and is shown in fig. 3.

The phase detector produces a waveform with variable duty cycle which depends on the phase and frequency difference between its two input signals. The operating frequency range of the phase detector is 1.7 kHz to 3.5 kHz and it depends on the channel spacing.

The reference frequency is generated in a crystal oscillator whose output is divided by 1024 and applied to the phase detector.

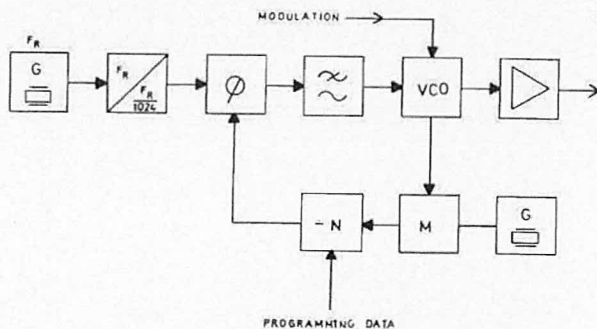

Fig. 2. Phase Locked loop PRINCIPLE

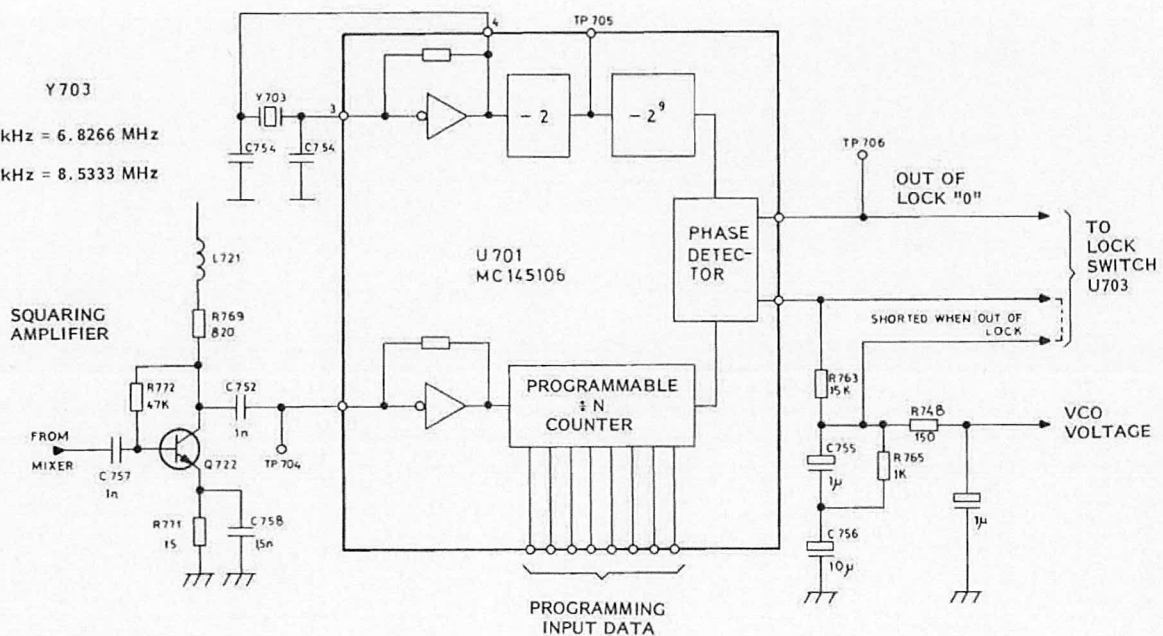

Fig. 3. REFERENCE OSCILLATOR, DIVIDER, AND PHASE DETECTOR

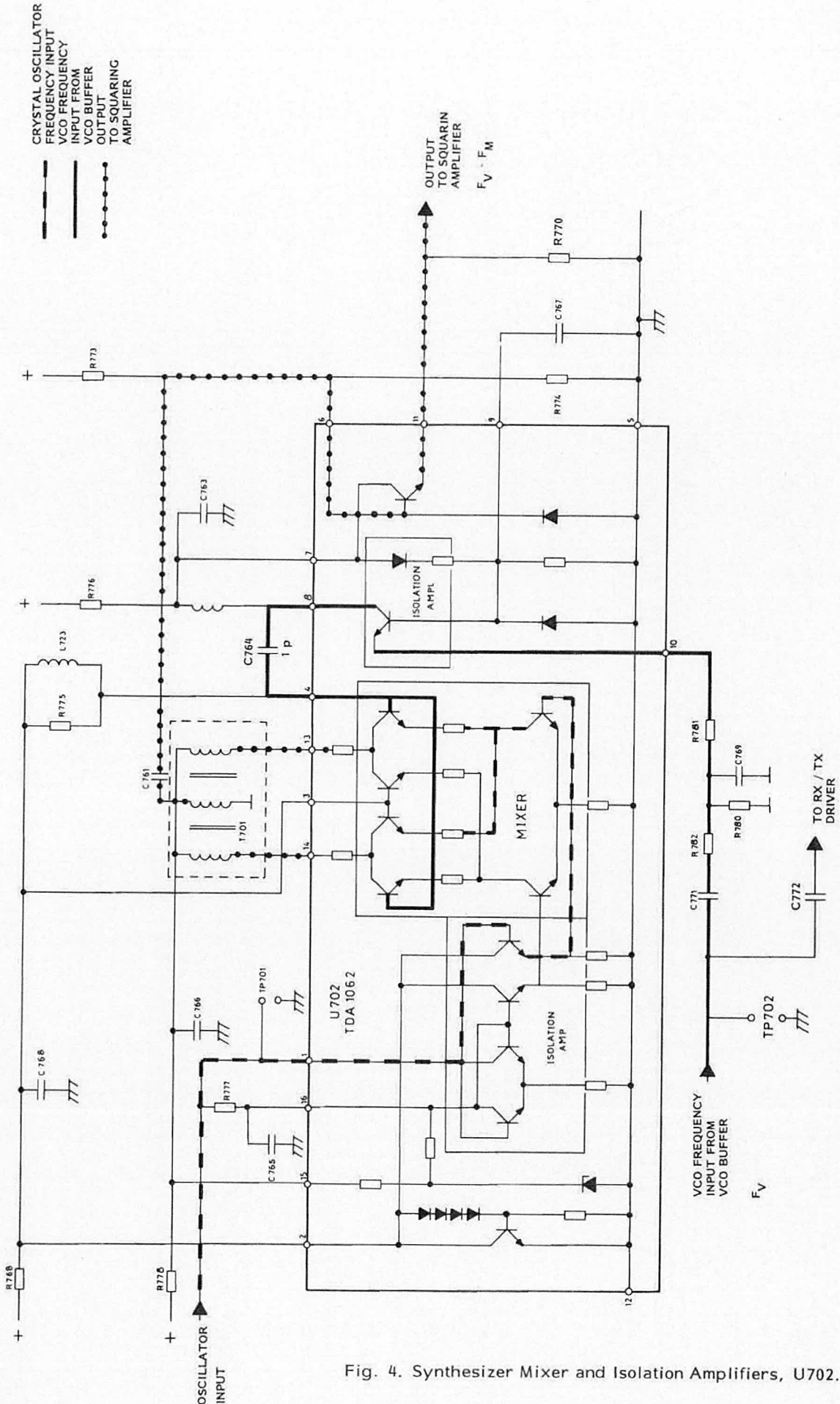

Fig. 4. Synthesizer Mixer and Isolation Amplifiers, U702.

The output from the phase detector passes through a passive integrating filter which produces a DC voltage proportional to the duty cycle of the phase detector output. This voltage adjusts the frequency of the VCO.

An out-of-lock circuit inhibits the transmitter when the synthesizer loop is out of lock and hunting for the frequency.

The transmitter modulation is applied simultaneously to the transmitter mixer-oscillator and the VCO. The modulation bandwidth also covers sub-audio frequencies used for channel guard (pilot tones). The frequency deviation balance adjustment equalizes the deviation on both oscillators to ascertain low distortion and low noise reference side bands during modulation of the synthesizer because it is operating with a relatively large loop bandwidth.

The frequency control module, FC5001, is built on a separate wiring board which mounts on top of the synthesizer shield. This module converts the BCD-code (4 bits) from the channel selector to an 8-bit binary code for the programmable dividers in the synthesizer loop. These 8-bit codes are programmed into a PROM (Programmable Read Only Memory) and are dividing factors expressed in hexadecimal codes.

On the FC5001 is a 5-Volt regulator which supplies the voltage for the PROM. When the PTT button is pushed the transistor Q801 converts the PTT voltage level to TTL level and puts a logic "0" on the MSB (Most Significant Bit) on the address input of the PROM. This selects the PROM code for the corresponding transmitter channel. The PROM outputs have open collectors with external pull-up resistors.

TECHNICAL SPECIFICATIONS

Supply Voltage

+8.5 Volts regulated
+13.2 Volts unregulated

Current Consumption

max. 80 mA (+8.5 V)
max. 200 mA (+13.2 V)

Channel Spacing

30/25 kHz
20 kHz
15/30 kHz

Modulation Input

0.75 V r. m. s. ± 2 dB
 $\Delta f = 60\% f_{\text{mod}} = 1$ kHz

Modulation Bandwidth

70 - 3000 Hz

Modulation Distortion

70 - 300 Hz: <5%
1 kHz: <4%

DC Temperature Stabilization Voltage

25°C = 6 V $\pm 10\%$ (reference)
-30°C = +350 mV $\pm 10\%$
-10°C = -50 mV $\pm 10\%$
+60°C = +50 mV $\pm 10\%$

The voltage characteristic is approximately linear between these points.

RF Output Level

4 mW ± 1 mW
(open collector output connected to tuned circuit)

TX Output Frequency Range

370 - 420 MHz (VCO)

RX Output Frequency Range

116 - 132 MHz (VCO)

Frequency Stability

5 p.p.m. or 10 p.p.m.

Reference Crystal Frequency

20 kHz: 10.240 MHz

12.5/25 kHz: 12.800 MHz

Signal-to-Noise Ratio (S/N)

>100 dB

 $\Delta f = 25$ kHz, BW (Bandwidth) = 10 kHzSpurious Attenuation

>85 dB

Lock Time

<30 m sec.

for 1 MHz step

Logic Control Level

LOW= <2 V

HIGH= >6 V

8 bit binary positive logic with built-in pull down resistors, $I_{in} = 175$ uA per bit.Temperature range -30°C to $+60^{\circ}\text{C}$ Dimensions

135 x 190 x 45 mm (BxDxH)

Weight

PC board: 150 g

Shield: 75 g

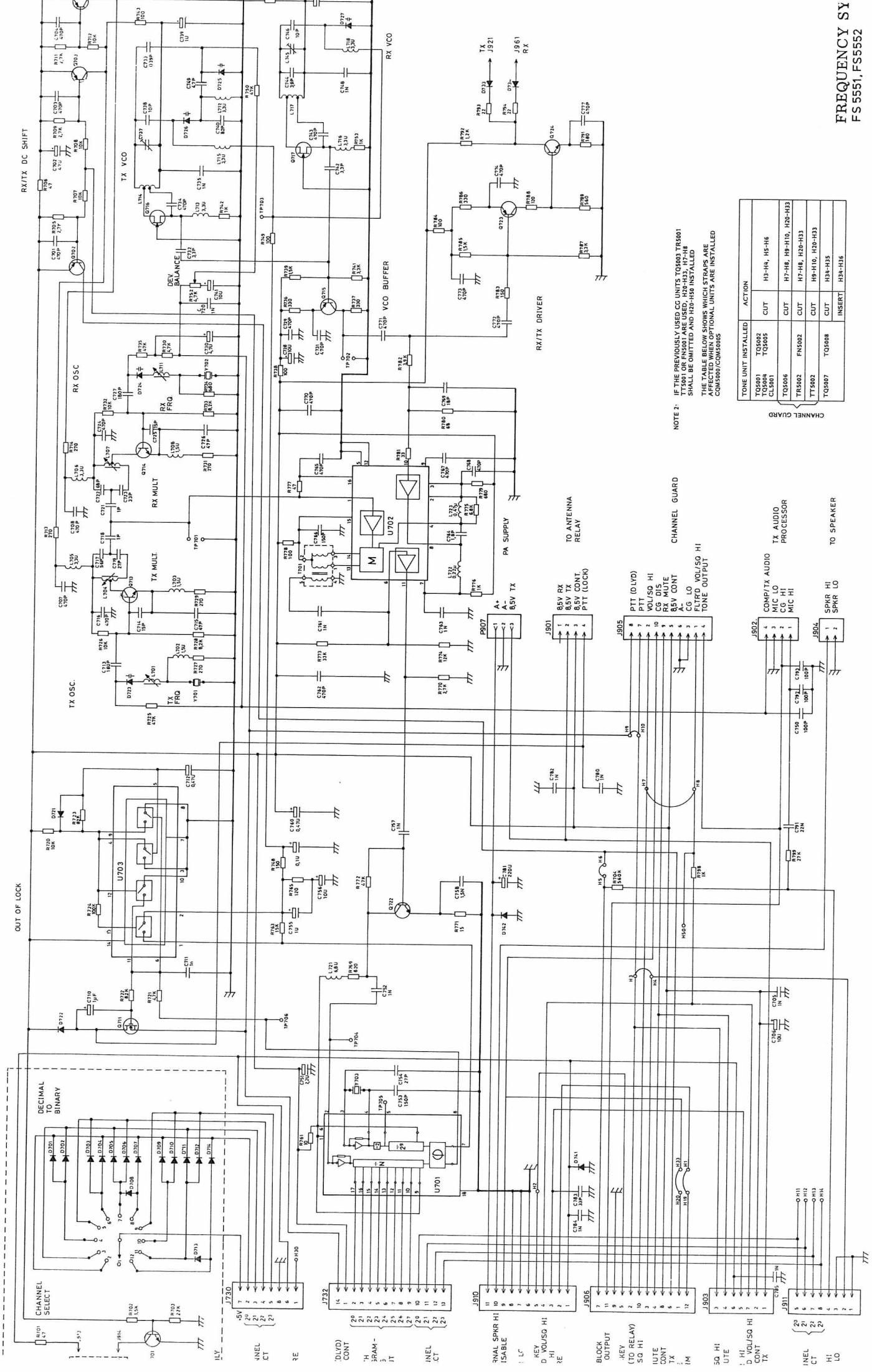

NOTE 2: IF THE PREVIOUSLY USED CG UNITS TO5003 TR5001 TO5004 OR TO5005 ARE INSTALLED IN THE CHANNEL GUARD, THE TABLE BELOW SHOWS WHICH STRAPS ARE AFFECTED WHEN OPTIONAL UNITS ARE INSTALLED COM5000/COM5005

CG UNIT	STRAP	ACTION
TO5001	TO5002	CUT
	TO5003	CUT
	TO5004	CUT
	TO5005	CUT
TR5006	FN5002	CUT
	TT5002	CUT
TO5007	TO5008	CUT
	TO5009	INSERT

CHANNEL GUARD

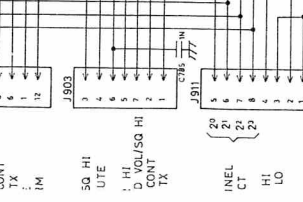
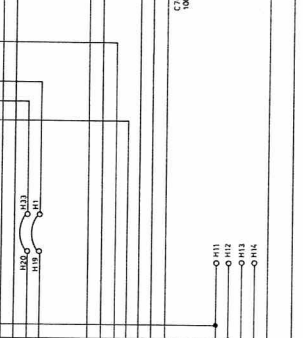
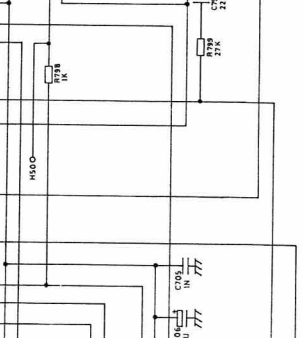
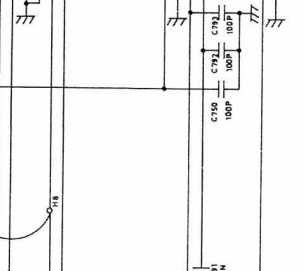
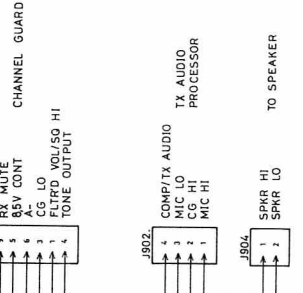

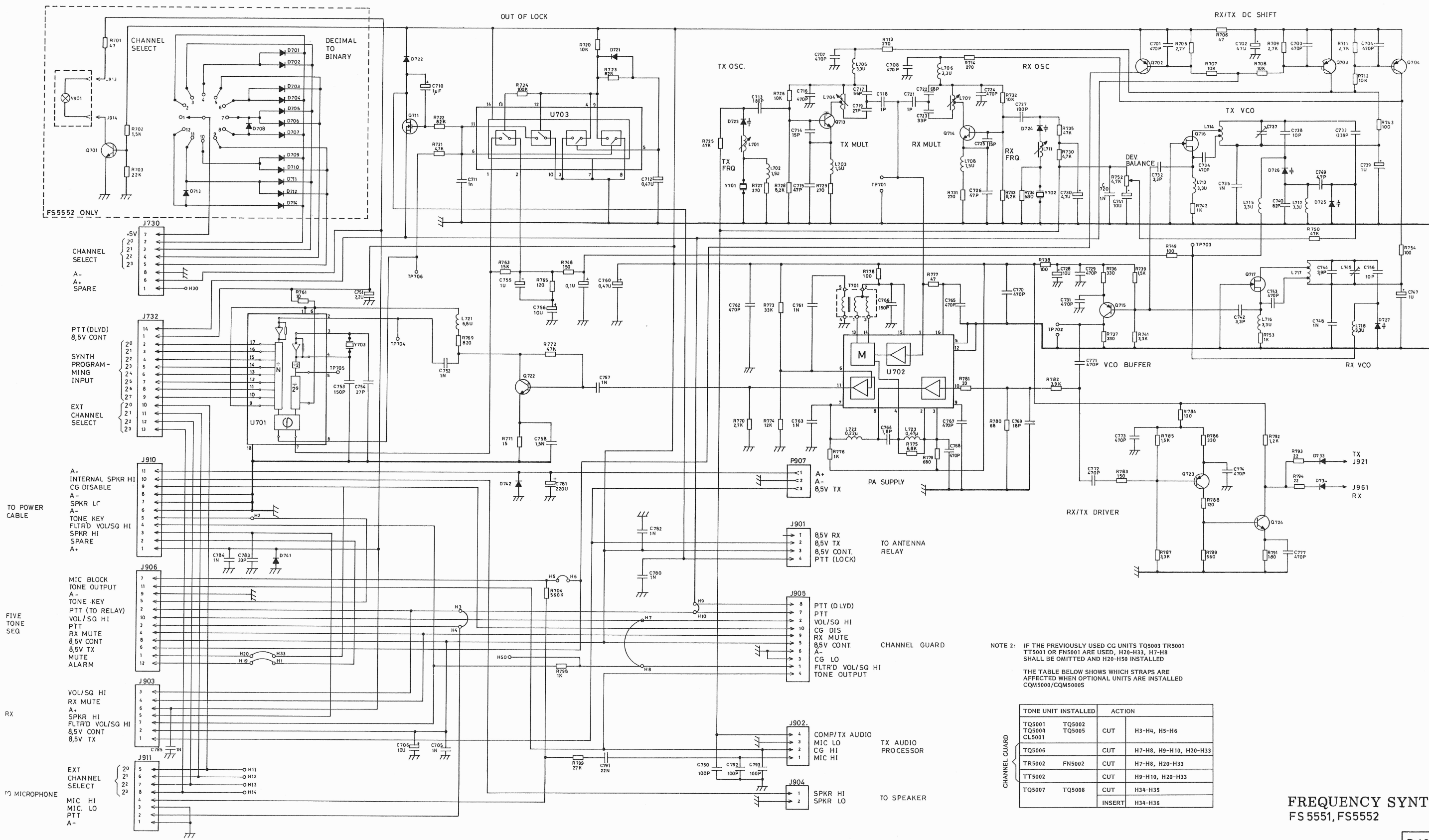

FREQUENCY SYNTHESIZER
FS 5551, FS5552

D403.037/2

Nº	CODE	DATA
C701	19A700233P5	470 pF Capacitor Ceramic
C702	19J706005P3	47 uF Capacitor Electrolytic
C703	19A700233P5	470 pF Capacitor Ceramic
C704	19A700233P5	470 pF Capacitor Ceramic
C705	19A700233P7	1 nF Capacitor Ceramic
C706	19A700003P7	10 uF Capacitor Tantalum
C707	19A700233P5	470 pF Capacitor Ceramic
C708	19A700233P5	470 pF Capacitor Ceramic
C711	19A700003P1	0.1 uF Capacitor Tantalum
C712	19A700003P5	2.2 uF Capacitor Tantalum
C713	19A700235P28	180 pF Capacitor Ceramic
C714	19J706256P201	15 pF N1500 Capacitor Ceramic
C715	19J706256P204	47 pF N1500 Capacitor Ceramic
C716	19A700233P5	470 pF Capacitor Ceramic
C717	19A700235P22	56 pF Capacitor Ceramic
C718	19A700235P7	3.3 pF Capacitor Ceramic
C719	19A700235P18	27 pF Capacitor Ceramic
C720	19A700233P7	1 nF Capacitor Ceramic
C721	19A700235P7	3.3 pF Capacitor Ceramic
C722	19A700235P23	68 pF Capacitor Ceramic
C723	19A700235P19	33 pF Capacitor Ceramic
C724	19A700233P5	470 pF Capacitor Ceramic
C725	19J706256P201	15 pF N1500 Capacitor Ceramic
C726	19J706256P204	47 pF N1500 Capacitor Ceramic
C727	19A700235P28	180 pF Capacitor Ceramic
C728	19A700003P7	10 uF Capacitor Tantalum
C729	19A700233P5	470 pF Capacitor Ceramic
C730	19A700003P6	4.7 uF Capacitor Tantalum
C731	19A700233P5	470 pF Capacitor Ceramic
C732	19A700235P7	3.3 pF Capacitor Ceramic
C733	19A700013P8	0.39 pF Capacitor Phenolic
C734	19A700233P5	470 pF Capacitor Ceramic
C735	19A700233P7	1 nF Capacitor Ceramic
C737	19J706003P1	1.8-10 pF Capacitor Variable
C738	19A700235P13	10 pF Capacitor Ceramic
C739	19A700003P4	1 uF Capacitor Tantalum
C740	19A700235P7	82 pF Capacitor Ceramic
C741	19A700003P7	10 uF Capacitor Tantalum
C742	19A700235P7	3.3 pF Capacitor Ceramic
C743	19A700233P5	470 pF Capacitor Ceramic
C744	19A700235P8	3.9 pF Capacitor Ceramic
C745	19J706003P2	2-18 pF Capacitor Variable
C746	19A700235P13	10 pF Capacitor Ceramic
C747	19A700003P4	1 uF Capacitor Tantalum
C748	19A700233P7	1 nF Capacitor Ceramic
C749	19A700235P9	4.7 pF Capacitor Ceramic

Nº	CODE	DATA
C750	19A700233P1	100 pF Capacitor Ceramic
C751	19A700003P5	2.2 uF Capacitor Tantalum
C752	19A700233P7	1 nF Capacitor Ceramic
C753	19A700233P2	150 pF Capacitor Ceramic
C754	19A700235P18	27 pF Capacitor Ceramic
C755	19A700003P4	1 uF Capacitor Tantalum
C756	19A700003P7	10 uF Capacitor Tantalum
C757	19A700233P7	1 nF Capacitor Ceramic
C758	19A700233P8	1.5 nF Capacitor Ceramic
C759	19A700003P4	1 uF Capacitor Tantalum
C760	19A700003P3	0.47 uF Capacitor Tantalum
C761	19A700233P7	1 nF Capacitor Ceramic
C762	19A700233P5	470 pF Capacitor Ceramic
C763	19A700233P7	1 nF Capacitor Ceramic
C764	19A700235P4	1.8 pF Capacitor Ceramic
C765	19A700233P5	470 pF Capacitor Ceramic
C766	19A700233P5	470 pF Capacitor Ceramic
C767	19A700233P5	470 pF Capacitor Ceramic
C768	19A700233P5	470 pF Capacitor Ceramic
C769	19A700235P16	18 pF Capacitor Ceramic
C770	19A700233P5	470 pF Capacitor Ceramic
C771	19A700233P5	470 pF Capacitor Ceramic
C772	19A700233P5	470 pF Capacitor Ceramic
C773	19A700233P5	470 pF Capacitor Ceramic
C774	19A700233P5	470 pF Capacitor Ceramic
C776	19A700235P13	10 pF Capacitor Ceramic
C777	19A700233P5	470 pF Capacitor Ceramic
C780	19A700233P5	1 nF Capacitor Ceramic
C781	19J706005P5	220 uF Capacitor Electrolytic
C782	19A700233P7	1 nF Capacitor Ceramic
C783	19A700235P19	33 pF Capacitor Ceramic
C784	19A700233P7	1 nF Capacitor Ceramic
C785	19A700233P7	1 nF Capacitor Ceramic
C791	19J706261P1	22 nF Capacitor Polyester
C792	19A700233P1	100 pF Capacitor Ceramic
C793	19A700233P1	100 pF Capacitor Ceramic
D721	19A700028P1	1N4148 Diode Silicon
D722	19A700028P1	1N4148 Diode Silicon
D723	19A706262P1	Variable Cap. Diode
D724	19J706262P1	Variable Cap. Diode

FREQUENCY SYNTHESIZER FS5551

X403.047

NO	CODE	DATA
D725	19A700073P1	BB409 Variable Cap. Diode
D726	19A700073P1	BB409 Variable Cap. Diode
D727	19A700073P1	BB409 Variable Cap. Diode
D733	19J706006P2	BA282 Diode
D734	19J706006P2	BA282 Diode
D741	19J706026P1	1N5401 Diode Silicon
D742	19J706026P1	1N5401 Diode Silicon
J730	19J706215P108	Male Connector
J732	19J706215P114	Male Connector
J901	19J706214P4	Male Connector
J902	19J706214P4	Male Connector
J903	19J706214P7	Male Connector
J904	19A700072P28	Male Connector
J905	19A700072P9	Male Connector
J906	19A700072P11	Male Connector
J907	19A700102P21	Female Connector
J910	19J706223P11	Male Connector
J911	19J706223P8	Male Connector
J921	19J706219P1	Male Connector
J961	19J706219P1	Male Connector
L701	19J706029P	Variable Coil
L702	19A700024P15	1.5 uH Coil
L703	19A700024P15	1.5 uH Coil
L704	19J706083P1	Coil
L705	19A700024P19	3.3 uH Coil
L706	19A700024P19	3.3 uH Coil
L707	19J706083P1	Variable Coil
L708	19A700024P15	1.5 uH Coil
L711	19J706029P2	Variable Coil
L712	19A700024P19	3.3 uH Coil
L713	19A700024P19	3.3 uH Coil
L714	19J706258P4	Coil
L715	19A700024P19	3.3 uH Coil
L716	19A700024P19	3.3 uH Coil
L717	19J706258P4	Coil
L718	19A700024P19	3.3 uH Coil
L721	19A700024P23	6.8 uH Coil
L722	19A700024P5	0.22 uH Coil
L723	19A700024P9	0.47 uH Coil
Q702	19A700020P1	BC558 Transistor
Q703	19A700020P1	BC558 Transistor
Q704	19A700020P1	BC558 Transistor
Q711	19A700017P2	BC548 Transistor
Q713	19J706283P1	BFR54 Transistor
Q714	19J706283P1	BFR54 Transistor
Q715	19J706264P1	BF414 Transistor

NO	CODE	DATA
Q716	19J706038P1	2N5245 Transistor
Q717	19J706038P1	2N5245 Transistor
Q722	19J706146P1	BF357S Transistor
Q723	19J706164P1	BF414 Transistor
Q724	19J706146P1	BF357S Transistor
R704	19A700019P34	560 ohm Resistor Depos.
R705	19A700019P42	2.7 Kohm Resistor Depos.
R706	19A700019P21	47 ohm Resistor Depos.
R707	19A700019P49	10 Kohm Resistor Depos.
R708	19A700019P49	10 Kohm Resistor Depos.
R709	19A700019P42	2.7 Kohm Resistor Depos.
R711	19A700019P42	2.7 Kohm Resistor Depos.
R712	19A700019P49	10 Kohm Resistor Depos.
R713	19A700019P17	22 ohm Resistor Depos.
R714	19A700019P17	22 ohm Resistor Depos.
R720	19A700019P37	1 Kohm Resistor Depos.
R721	19A700019P45	4.7 Kohm Resistor Depos.
R722	19A700019P60	82 Kohm Resistor Depos.
R723	19A700019P58	56 Kohm Resistor Depos.
R724	19A700019P49	10 Kohm Resistor Depos.
R725	19A700019P57	47 Kohm Resistor Depos.
R726	19A700019P49	10 Kohm Resistor Depos.
R727	19A700019P30	270 ohm Resistor Depos.
R728	19A700019P48	8.2 Kohm Resistor Depos.
R729	19A700019P30	270 ohm Resistor Depos.
R730	19A700019P45	4.7 Kohm Resistor Depos.
R732	19A700019P49	10 Kohm Resistor Depos.
R733	19A700019P48	8.2 Kohm Resistor Depos.
R734	19A700019P35	680 ohm Resistor Depos.
R735	19A700029P57	47 Kohm Resistor Depos.
R736	19A700029P31	330 ohm Resistor Depos.
R737	19A700019P31	330 ohm Resistor Depos.
R738	19A700019P25	100 ohm Resistor Depos.
R739	19A700019P39	1.5 Kohm Resistor Depos.
R741	19A700019P43	3.3 Kohm Resistor Depos.
R742	19A700019P37	1 Kohm Resistor Depos.
R743	19A700019P25	100 ohm Resistor Depos.
R748	19A700019P27	150 ohm Resistor Depos.
R749	19A700019P25	100 ohm Resistor Depos.
R750	19A700019P57	47 Kohm Resistor Depos.

FREQUENCY SYNTHESIZER FS5551

X403.047

Nº	CODE	DATA
R752	19A700016P3	4. 7 Kohm Resistor Variable
R753	19A700019P37	1 Kohm Resistor Depos.
R754	19A700019P25	100 ohm Resistor Depos.
R761	19A700019P13	10 ohm Resistor Depos.
R763	19A700019P51	15 Kohm Resistor Depos.
R765	19A700019P26	120 ohm Resistor Depos.
R769	19A700019P35	820 ohm Resistor Depos.
R770	19A700019P42	2. 7 Kohm Resistor Depos.
R771	19A700019P15	15 ohm Resistor Depos.
R772	19A700019P57	47 Kohm Resistor Depos.
R773	19A700019P55	33 Kohm Resistor Depos.
R774	19A700019P50	12 Kohm Resistor Depos.
R775	19A700019P47	6. 8 Kohm Resistor Depos.
R776	19A700010P37	1 Kohm Resistor Depos.
R777	19A700019P21	47 ohm Resistor Depos.
R778	19A700019P25	100 ohm Resistor Depos.
R779	19A700019P35	680 ohm Resistor Depos.
R780	19A700019P23	68 ohm Resistor Depos.
R781	19A700019P19	33 ohm Resistor Depos.
R782	19A700019P44	3. 9 Kohm Resistor Depos.
R783	19A700019P27	150 ohm Resistor Depos.
R784	19A700019P25	100 ohm Resistor Depos.
R785	19A700019P39	1. 5 Kohm Resistor Depos.
R786	19A700019P31	330 ohm Resistor Depos.
R787	19A700019P43	3. 3 Kohm Resistor Depos.
R788	19A700019P26	120 ohm Resistor Depos.
R789	19A700019P34	560 ohm Resistor Depos.
R791	19A700019P28	180 ohm Resistor Depos.
R792	19A700019P38	1. 2 Kohm Resistor Depos.
R793	19A700019P17	22 ohm Resistor Depos.
R794	19A700019P17	22 ohm Resistor Depos.
R798	19A700019P37	1 Kohm Resistor Depos.
R799	19A700019P54	27 Kohm Resistor Depos.
T701	19J706284G1	Transformer
U701	19J706263P1	MC145106
U702	19J706238P1	TDA1062 IC
U703	19A700029P44	4066B IC

Nº	CODE	DATA

FREQUENCY SYNTHESIZER FS5551

X403.047

No	CODE	DATA
C701	19A700233P5	470 pF Capacitor Ceramic
C702	19J706005P3	47 uF Capacitor Electrolytic
C703	19A700233P5	470 pF Capacitor Ceramic
C704	19A700233P5	470 pF Capacitor Ceramic
C705	19A700233P7	1 nF Capacitor Ceramic
C706	19A700003P7	10 uF Capacitor Tantalum
C707	19A700233P5	470 pF Capacitor Ceramic
C708	19A700233P5	470 pF Capacitor Ceramic
C711	19A700003P1	0.1 uF Capacitor Tantalum
C712	19A700003P5	2.2 uF Capacitor Tantalum
C713	19A700235P28	180 pF Capacitor Ceramic
C714	19J706256P201	15 pF N1500 Capacitor Ceramic
C715	19J706256P204	47 pF N1500 Capacitor Ceramic
C716	19A700233P5	470 pF Capacitor Ceramic
C717	19A700235P22	56 pF Capacitor Ceramic
C718	19A700235P7	3.3 pF Capacitor Ceramic
C719	19A700235P18	27 pF Capacitor Ceramic
C720	19A700233P7	1 nF Capacitor Ceramic
C721	19A700235P7	3.3 pF Capacitor Ceramic
C722	19A700235P23	68 pF Capacitor Ceramic
C723	19A700235P19	33 pF Capacitor Ceramic
C724	19A700233P5	470 pF Capacitor Ceramic
C725	19J706256P201	15 pF N1500 Capacitor Ceramic
C726	19J706256P204	47 pF N1500 Capacitor Ceramic
C727	19A700235P28	180 pF Capacitor Ceramic
C728	19A700003P7	10 uF Capacitor Tantalum
C729	19A700233P5	470 pF Capacitor Ceramic
C730	19A700003P6	4.7 uF Capacitor Tantalum
C731	19A700233P5	470 pF Capacitor Ceramic
C732	19A700235P7	3.3 pF Capacitor Ceramic
C733	19A700013P8	0.39 pF Capacitor Phenolic
C734	19A700233P5	470 pF Capacitor Ceramic
C735	19A700233P7	1 nF Capacitor Ceramic
C737	19J706003P1	1.8-10 pF Capacitor Variable
C738	19A700235P13	10 pF Capacitor Ceramic
C739	19A700003P4	1 uF Capacitor Tantalum
C740	19A700235P7	82 pF Capacitor Ceramic
C741	19A700003P7	10 uF Capacitor Tantalum
C742	19A700235P7	3.3 pF Capacitor Ceramic
C743	19A700233P5	470 pF Capacitor Ceramic
C744	19A700235P8	3.9 pF Capacitor Ceramic
C745	19J706003P2	2-18 pF Capacitor Variable
C746	19A700235P13	10 pF Capacitor Ceramic
C747	19A700003P4	1 uF Capacitor Tantalum
C748	19A700233P7	1 nF Capacitor Ceramic
C749	19A700235P9	4.7 pF Capacitor Ceramic

No	CODE	DATA
C750	19A700233P1	100 pF Capacitor Ceramic
C751	19A700003P5	2.2 uF Capacitor Tantalum
C752	19A700233P7	1 nF Capacitor Ceramic
C753	19A700233P2	150 pF Capacitor Ceramic
C754	19A700235P18	27 pF Capacitor Ceramic
C755	19A700003P4	1 uF Capacitor Tantalum
C756	19A700003P7	10 uF Capacitor Tantalum
C757	19A700233P7	1 nF Capacitor Ceramic
C758	19A700233P8	1.5 nF Capacitor Ceramic
C759	19A700003P4	1 uF Capacitor Tantalum
C760	19A700003P3	0.47 uF Capacitor Tantalum
C761	19A700233P7	1 nF Capacitor Ceramic
C762	19A700233P5	470 pF Capacitor Ceramic
C763	19A700233P7	1 nF Capacitor Ceramic
C764	19A700235P4	1.8 pF Capacitor Ceramic
C765	19A700233P5	470 pF Capacitor Ceramic
C766	19A700233P5	470 pF Capacitor Ceramic
C767	19A700233P5	470 pF Capacitor Ceramic
C768	19A700233P5	470 pF Capacitor Ceramic
C769	19A700235P16	18 pF Capacitor Ceramic
C770	19A700233P5	470 pF Capacitor Ceramic
C771	19A700233P5	470 pF Capacitor Ceramic
C772	19A700233P5	470 pF Capacitor Ceramic
C773	19A700233P5	470 pF Capacitor Ceramic
C774	19A700233P5	470 pF Capacitor Ceramic
C776	19A700235P13	10 pF Capacitor Ceramic
C777	19A700233P5	470 pF Capacitor Ceramic
C780	19A700233P7	1 nF Capacitor Ceramic
C781	19J706005P5	220 uF Capacitor Electrolytic
C782	19A700233P7	1 nF Capacitor Ceramic
C783	19A700235P19	33 pF Capacitor Ceramic
C784	19A700233P7	1 nF Capacitor Ceramic
C785	19A700233P7	1 nF Capacitor Ceramic
C791	19J706261P1	22 nF Capacitor Polyester
C792	19A700233P1	100 pF Capacitor Ceramic
C793	19A700233P1	100 pF Capacitor Ceramic
D701	19A700028P1	1N4148 Diode Silicon
D702	19A700028P1	1N4148 Diode Silicon
D703	19A700028P1	1N4148 Diode Silicon
D704	19A700028P1	1N4148 Diode Silicon

FREQUENCY SYNTHESIZER FS5552

X403.048

No	CODE	DATA
D705	19A700028P1	1N4148 Diode Silicon
D706	19A700028P1	1N4148 Diode Silicon
D707	19A700028P1	1N4148 Diode Silicon
D708	19A700028P1	1N4148 Diode Silicon
D709	19A700028P1	1N4148 Diode Silicon
D710	19A700028P1	1N4148 Diode Silicon
D711	19A700028P1	1N4148 Diode Silicon
D712	19A700028P1	1N4148 Diode Silicon
D713	19A700028P1	1N4148 Diode Silicon
D714	19A700028P1	1N4148 Diode Silicon
D721	19A700028P1	1N4148 Diode Silicon
D722	19A700028P1	1N4148 Diode Silicon
D723	19A706262P1	Variable Cap. Diode
D724	19A706262P1	Variable Cap. Diode
D725	19A700073P1	BB409 Variable Cap. Diode
D726	19A700073P1	BB409 Variable Cap. Diode
D727	19A700073P1	BB409 Variable Cap. Diode
D733	19J706006P2	BA282 Diode
D734	19J706006P2	BA282 Diode
D741	19J706026P1	1N5401 Diode Silicon
D742	19J706026P1	1N5401 Diode Silicon
J730	19J706215P108	Male Connector
J732	19J706215P114	Male Connector
J901	19J706214P4	Male Connector
J902	19J706214P4	Male Connector
J903	19J706214P7	Male Connector
J904	19A700072P28	Male Connector
J905	19A700072P9	Male Connector
J906	19A700072P11	Male Connector
J907	19A700102P21	Female Connector
J910	19J706223P11	Male Connector
J911	19J706223P8	Male Connector
J921	19J706219P1	Variable Coil
J961	19J706219P1	1.5 uH Coil
L701	19J706029P	1.5 uH Coil
L702	19A700024P15	Coil
L703	19A700024P15	3.3 uH Coil
L704	19J706083P1	3.3 uH Coil
L705	19A700024P19	Variable Coil
L706	19A700024P19	1.5 uH Coil
L707	19J706083P1	Variable Coil
L708	19A700024P15	Variable Coil
L711	19J706029P2	3.3 uH Coil
L712	19A700024P19	3.3 uH Coil
L713	19A700024P19	3.3 uH Coil
L714	19J706258P4	Coil

No	CODE	DATA
L715	19A700024P19	3.3 uH Coil
L716	19A700024P19	3.3 uH Coil
L717	19J706258P4	Coil
L718	19A700024P19	3.3 uH Coil
L721	19A700024P23	6.8 uH Coil
L722	19A700024P5	0.22 uH Coil
L723	19A700024P9	0.47 uH Coil
Q701	19A700017P1	BC548 Transistor
Q702	19A700020P1	BC558 Transistor
Q703	19A700020P1	BC558 Transistor
Q704	19A700020P1	BC558 Transistor
Q711	19A700017P2	BC548 Transistor
Q713	19J706283P1	BFR54 Transistor
Q714	19J706283P1	BFR54 Transistor
Q715	19J706264P1	BF414 Transistor
Q716	19J706038P1	2N5245 Transistor
Q717	19J706038P1	2N5245 Transistor
Q722	19J706146P1	BF357S Transistor
Q723	19J706146P1	BF414 Transistor
Q724	19J706146P1	BF357S Transistor
R701	19A700019P21	47 ohm Resistor Depos.
R702	19A700019P39	1.5 Kohm Resistor Depos.
R703	19A700019P53	22 Kohm Resistor Depos.
R704	19A700019P34	560 ohm Resistor Depos.
R705	19A700019P42	2.7 Kohm Resistor Depos.
R706	19A700019P21	47 ohm Resistor Depos.
R707	19A700019P49	10 Kohm Resistor Depos.
R708	19A700019P49	10 Kohm Resistor Depos.
R709	19A700019P42	2.7 Kohm Resistor Depos.
R711	19A700019P42	2.7 Kohm Resistor Depos.
R712	19A700019P49	10 Kohm Resistor Depos.
R713	19A700019P17	22 ohm Resistor Depos.
R714	19A700019P17	22 ohm Resistor Depos.
R720	19A700019P37	1 Kohm Resistor Depos.
R721	19A700019P45	4.7 Kohm Resistor Depos.
R722	19A700019P60	82 Kohm Resistor Depos.
R723	19A700019P58	56 Kohm Resistor Depos.
R724	19A700019P49	10 Kohm Resistor Depos.
R725	19A700019P57	47 Kohm Resistor Depos.
R726	19A700019P49	10 Kohm Resistor Depos.

FREQUENCY SYNTHESIZER FS5552

X403.048

N ^o	CODE	DATA
R727	19A700019P30	270 ohm Resistor Depos.
R728	19A700019P48	8. 2 Kohm Resistor Depos.
R729	19A700019P30	270 ohm Resistor Depos.
R730	19A700019P45	4. 7 Kohm Resistor Depos.
R732	19A700019P49	10 Kohm Resistor Depos.
R733	19A700019P48	8. 2 Kohm Resistor Depos.
R734	19A700019P35	680 ohm Resistor Depos.
R735	19A700029P57	47 Kohm Resistor Depos.
R736	19A700029P31	330 ohm Resistor Depos.
R737	19A700019P31	330 ohm Resistor Depos.
R738	19A700019P25	100 ohm Resistor Depos.
R739	19A700019P39	1. 5 Kohm Resistor Depos.
R741	19A700019P43	3. 3 Kohm Resistor Depos.
R742	19A700019P37	1 Kohm Resistor Depos.
R743	19A700019P25	100 ohm Resistor Depos.
R748	19A700019P27	150 ohm Resistor Depos.
R749	19A700019P25	100 ohm Resistor Depos.
R750	19A700019P57	47 Kohm Resistor Depos.
R752	19A700016P3	4. 7 Kohm Resistor Variable
R753	19A700019P37	1 Kohm Resistor Depos.
R754	19A700019P25	100 ohm Resistor Depos.
R761	19A700019P13	10 ohm Resistor Depos.
R763	19A700019P51	15 Kohm Resistor Depos.
R765	19A700019P26	120 ohm Resistor Depos.
R769	19A700019P35	820 ohm Resistor Depos.
R770	19A700019P42	2. 7 Kohm Resistor Depos.
R771	19A700019P15	15 ohm Resistor Depos.
R772	19A700019P57	47 Kohm Resistor Depos.
R773	19A700019P55	33 Kohm Resistor Depos.
R774	19A700019P50	12 Kohm Resistor Depos.
R775	19A700019P47	6. 8 Kohm Resistor Depos.
R776	19A700010P37	1 Kohm Resistor Depos.
R777	19A700019P21	47 ohm Resistor Depos.
R778	19A700019P25	100 ohm Resistor Depos.
R779	19A700019P35	680 ohm Resistor Depos.
R780	19A700019P23	68 ohm Resistor Depos.
R781	19A700019P19	33 ohm Resistor Depos.
R782	19A700019P44	3. 9 Kohm Resistor Depos.
R783	19A700019P27	150 ohm Resistor Depos.
R784	19A700019P25	100 ohm Resistor Depos.
R785	19A700019P39	1. 5 Kohm Resistor Depos.
R786	19A700019P31	330 ohm Resistor Depos.
R787	19A700019P43	3. 3 Kohm Resistor Depos.
R788	19A700019P26	120 ohm Resistor Depos.
R789	19A700019P34	560 ohm Resistor Depos.
R791	19A700019P28	180 ohm Resistor Depos.

N ^o	CODE	DATA
R792	19A700019P38	1. 2 Kohm Resistor Depos.
R793	19A700019P17	22 ohm Resistor Depos.
R794	19A700019P17	22 ohm Resistor Depos.
R798	19A700019P37	1 Kohm Resistor Depos.
R799	19A700019P54	27 Kohm Resistor Depos.
S901	19J706322G1	Channel Switch
T701	19J706284G1	Transformer
U701	19J706263P1	MC145106
U702	19J706238P1	TDA1062 IC
U703	19A700029P44	4066B IC

FREQUENCY SYNTHESIZER FS5552

X403. 048

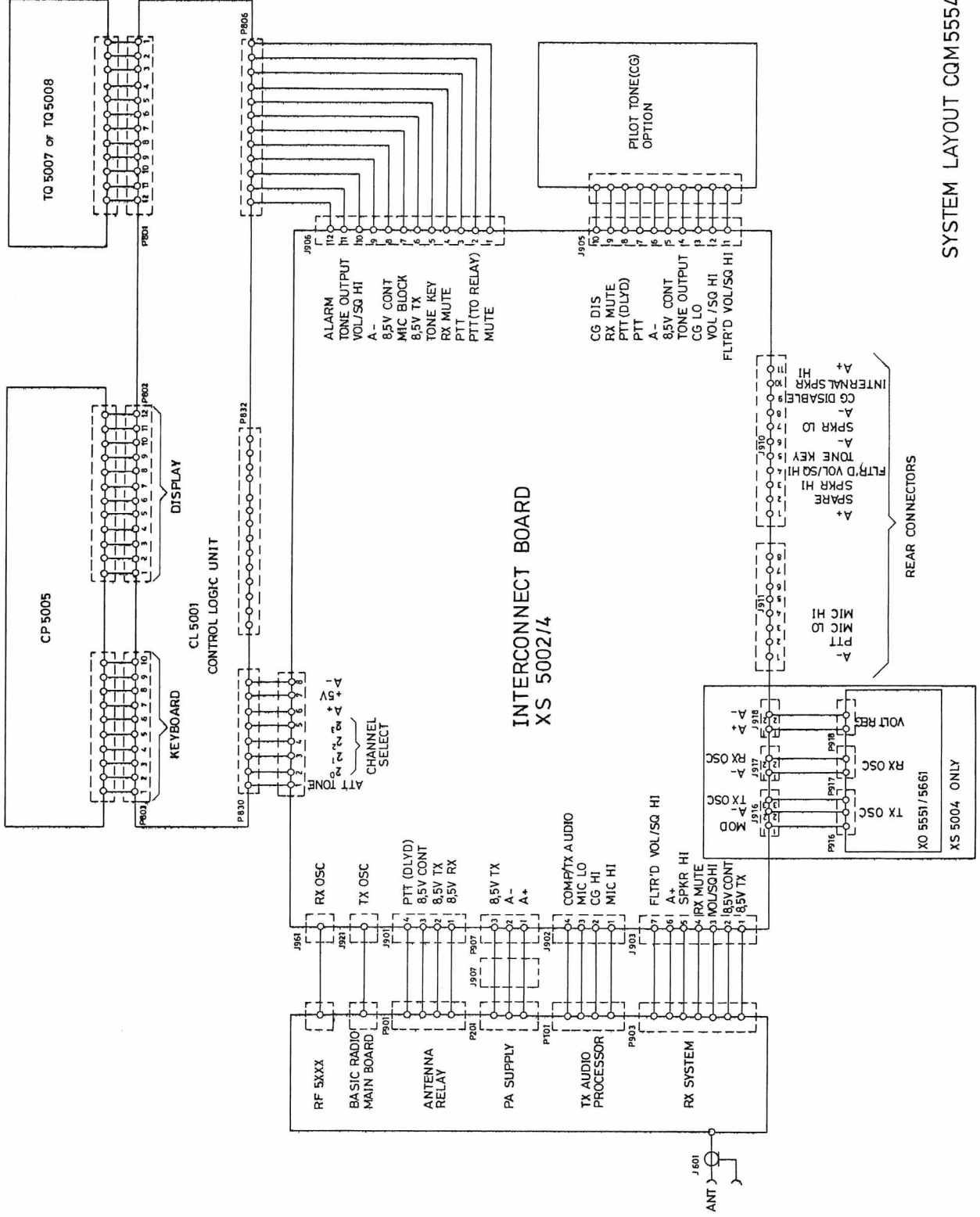

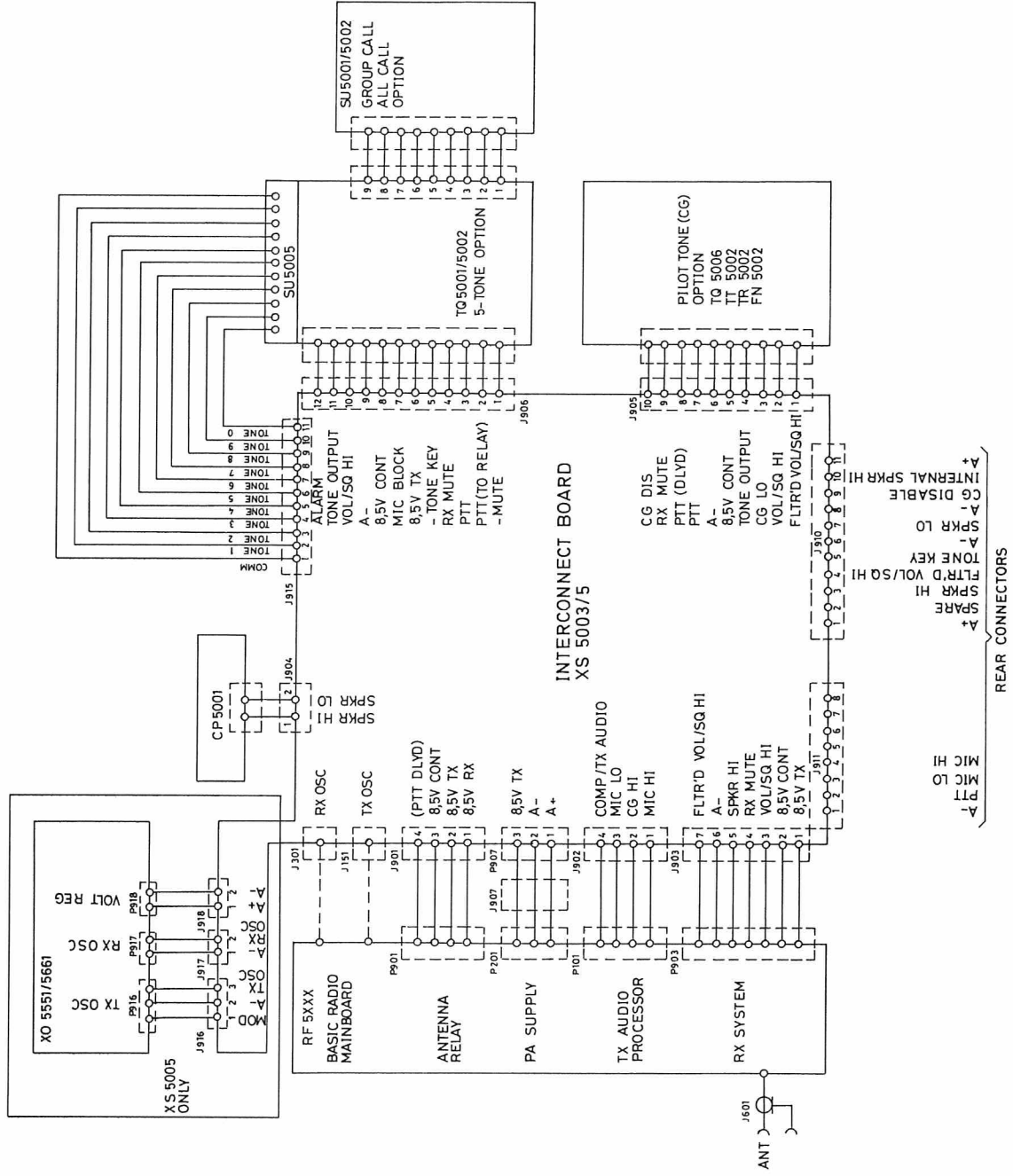

SYSTEM LAYOUT QCM5000 (F)
10-TONE CALL

TECHNICAL SPECIFICATIONS

CQM5660 S12

Guaranteed performance specifications unless otherwise noted.

Typical values are given in brackets.

GENERAL

Frequency Range

420 - 470 MHz

Maximum Number of Channels

12

Channel Separation

CQM5662: 30/25 kHz

CQM5663: 20 kHz

Supply Voltage

Minimum: 10.8 V

Nominal: 13.2 V

Maximum: 16.6 V

Negative potential to chassis

Maximum Frequency Deviation

CQM5662: ± 5 kHz

CQM5663: ± 4 kHz

Temperature Range

-30°C to $+60^{\circ}\text{C}$

Modulation Frequency Range

300 - 3000 Hz

Dimensions

B x D x H: 180 x 190 x 60 mm

Maximum RF Bandwidth

RX: 3.0 MHz

TX: 5.5 MHz

Weight

1.8 kg

Antenna Impedance

50 ohm

RECEIVER

Sensitivity

12 dB SINAD (EIA), $\frac{1}{2}$ e.m.f.

0.4 μV (0.3 μV)

ΔF 60% x Δf_{max} ; $f_{\text{mod}} = 1$ kHz.

Measured with psophometric filter.

Measuring conditions:

Δf , $\pm 2/3$ x Δf_{max} ; $f_{\text{mod}} = 1$ kHz

20 dB SINAD (CEPT) e.m.f.

1.0 μV (0.7 μV)

Crystal Frequency Range

420 - 450 MHz: 47 - 50 MHz

440 - 470 MHz: 45 - 48 MHz

Receiver VCO Frequency Range

139 - 157 MHz

Crystal Frequency Multiplication

x3

Frequency Stability

Conforms with governments regulations

Modulation Acceptance Bandwidth (EIA)

± 7 kHz (±7.5 kHz)

Adjacent Channel Selectivity

EIA

75 dB (80 dB)

CEPT

75 dB (80 dB)

Spurious Rejection

EIA

85 dB

Intermodulation Attenuation

EIA

70 dB

CEPT

70 dB (78 dB)

Blocking

90 dB/uV (100 dB/uV)

Radiation

Conducted: max. 0.8 nW

Radiated: max. 0.8 nW

AF Load Impedance (Loudspeaker)

4 ohm

AF Power Output

3 W (3.6 W)

AF Distortion

5% (1.5%)

 $\Delta f = \pm 3$ kHz, 1 kHz, 1 W, RF 1 mVFrequency ResponseCQM5662 S12, CQM5663 S12

+1/-3 dB (+0/-1.5 dB) CEPT

Relative to 1000 Hz, -6 dB/octave

fm: 300 - 3000 Hz

CQM5663 S12

+1/1.5 dB (+0/-1 dB) CEPT/FTZ

Relative to 1000 Hz, -6 dB/octave

fm: 400 - 2700 Hz

Hum and Noise

Squelched : 80 dB (better than 85 dB)

Unsquelched : 55 dB (57 dB)

Squelch Recovery Time

250 ms (200 ms)

Squelch Attack Time, EIA

150 ms (110 ms)

Squelch Closing Time, EIA

150 ms (50 ms)

Current Consumption

Squelched: 350 mA (330 mA)

AF 2 W : 750 mA (730 mA)

(1 channel, without tone equipment, 13.2 V supply)

TRANSMITTER

RF Power Output

CQM5660-5 W: 5 W

CQM5660-20 W: 20 W

 $R_L = 50$ ohmCrystal Frequency Range

45 - 50 MHz

Crystal Frequency Multification

x3

Transmitter VCO Frequency Range

140 - 156 MHz

Frequency Stability

Conforms with government regulations

Undesired Radiationmax. 0.2 μ WSideband Noise Power, CEPT

less than 70 dB

AF Input Impedance

560 ohm

Modulation Sensitivity90 mV \pm 3 dB(60%, $\Delta f = \pm 3$ kHz, 1 kHz)Modulation Response

300 - 3000 Hz

+1/-3.0 dB (+0.5/-2 dB)

relative to 1000 Hz, 6 dB/octave

400 - 2700 Hz+1/-1.5 dB (+0.5/-1 dB) relative to 1000 Hz,
6 dB/octaveModulation Distortion

fm = 1000 Hz: max. 3%

fm = 300 Hz: max. 5%

CQM5662: $\Delta f = \pm 3$ kHzCQM5663: $\Delta f = \pm 2.4$ kHzFM Hum and Noise

55 dB (57 dB)

CEPT (measured with 750 usec de-emphasis)

Attack Time

50 ms

Current Consumption

5 W: less than 1.8 A (1.5 A)

20 W: less than 5.5 A (5 A)

GENERAL DESCRIPTION

CQM5660 S12

The Stornophone 5000 is a mobile radiotelephone unit with self-contained controls and loudspeaker.

A comparison of the various models is presented in the table below.

Although compact in size, it contains a transmitter/receiver, optional 5-tone sequential encoder/decoder or Channel Guard, and up to 12 transmit and receive channels.

Type	CQM5662		CQM5663	
SPEC	5	20	5	20
Frequency Range MHz	420 - 470		420 - 470	
RF Power W	5	20	5	20
Channel Spacing kHz	30/25		20	
Max. Number of Channels	12		12	

ACCESSORIES

STANDARD ACCESSORIES

Mounting frame

Power cable

First microphone with retainer or

Fixed - mount microphone

External loudspeaker

External switches

LS701 Loudspeaker enclosed in a plastic housing, complete with cable.

MC702b Dynamic fist microphone with adjustable output level.

JB701a Junction box for MC702b. Consists of a plastic housing provided with cable for soldering assembly. Junction box is to mounted behind the first microphone retainer.

MC703a Desk microphone with PTT (Push -to - Talk) switch for fixed installations.

MC704 Microphone with chockabsorbing mounting bracket for mobile installation.

MK704 Mounting kit consisting of 2 flexible tubes, used for mounting the MC704 in close-talk position.

MC5001

First microphone with retractable spiral cable for mobile installation.

HS5001

Retainer for MC5001

HS5002

Retainer, with switches, for MC5001

MC5002

Cylindrical handmicrophone with build-in amplifier and press-to talk switch. Fitted with a coiled cord terminated into a connector which fits into the microphone retainer.

HS5003

Retainer for MC5002, without hook switch.

HS5004

Retainer for MC5002, with hook switch.

MK5001

Installation kit containing connectors, power cable, fuses and fuseholders.

MN703

Desk stand for fixed installations.

MN704

Mounting bracket for the radio cabinet.

MN5001

Mounting frame for mobile installations allowing the radio to be fixed in 36 positions. Includes a base plate with locking screw.

MN5002

Mounting cassette for the radio cabinet (see mechanical layout).

MT5001

Microphone with retainer. The retainer contains a microswitch which is

- used to switch off the internal loud-speaker, when the microphone is lifted.
- SU701 Transmitter keying switch for mounting on the steering column.
- SU702 Transmitter keying switch for mounting on the dashboard.
- SU704 Switch circuit for autoradio mounting.
- SU5003 External alarm with timer (Horn Alarm).

POWER SUPPLY UNITS:

Equipment	SUPPLY	VOLTAGE
	220V AC	+24V DC
CQM5000, max. 5 W	PS703	PS704
CQM5000, max. 20 W	PS5001	PS702

MECHANICAL AND ELECTRICAL DESCRIPTION

The internal construction of CQM5000 is on an H-frame chassis with a shelf separating the receiver/transmitter (RF) printed circuit board and the various option printed boards. Front panel controls are an integral part of the printed board assemblies.

The chassis is a die cast aluminium frame comprising the left and right sides, the back, and a shelf located midway between the top and bottom. The chassis front is open and looks like an "H" viewed from the front.

Interconnection to the package exterior and to internal options are made via the Frequency Synthesizer Board located on the option side of the H-frame. A test connector is also located on the synthesizer board and is accessible from the rear of the radio.

The moulded plastic front is directly attached to the chassis and has the speaker mounted to it. A separate moulded speaker grill and aluminum nameplate are attached to the front.

The top and bottom covers slide under the edge of the front and are then secured by screws at the rear.

The tone signalling encoder/decoder board (TQ), the Frequency Synthesizer Board (FS) and the Frequency Control (FC) mount in the top section of the chassis. Their switches and push buttons mount directly to the boards and protrude through the front.

Thin casted shields with adjustment holes are placed over the transmitter and receiver oscillators and parts of the transmitter in order to reduce spurious radiation.

CIRCUIT DESCRIPTION

RECEIVER

The receiver circuitry is placed on the main board and can be divided into:

- Receiver front end
- 1st IF section with first and second oscillator.
- 455 kHz 2nd IF section with demodulator.

(refer to functional block diagram)

FRONT-END

The receiver front-end consists of a dual-resonator input filter, a transistor RF amplifier, Q401, a triple-resonator intermediate filter and a FET mixer, Q402. The drain of the FET is terminated in the first IF resonant circuit which adapts the output impedance to the crystal filter. The front-end, antenna relay, first mixer and part of the transmitter PA interconnections are designed in micro-stripline techniques on the mainboard.

1ST IF

The first IF frequency is 21.4 MHz. The output from the crystal filter is fed to a dual-gate MOS-FET amplifier, Q501, the output signal of which is fed to the second mixer, U501, a single balanced, self-oscillating, active mixer. Out of the second mixer comes the 455 kHz IF signal. Two diodes, D501-502, limit the output from the mixer.

455 kHz IF/DEMODULATOR

The selectivity of the 455 kHz IF amplifier is formed by a ceramic filter fed from a 455 kHz amplifier/impedance transforming stage. The final 455 kHz amplification and limiting is performed by an integrated circuit, U502, which also contains the quadrature FM detector and the AF amplifier/output emitter follower for the audio line signal.

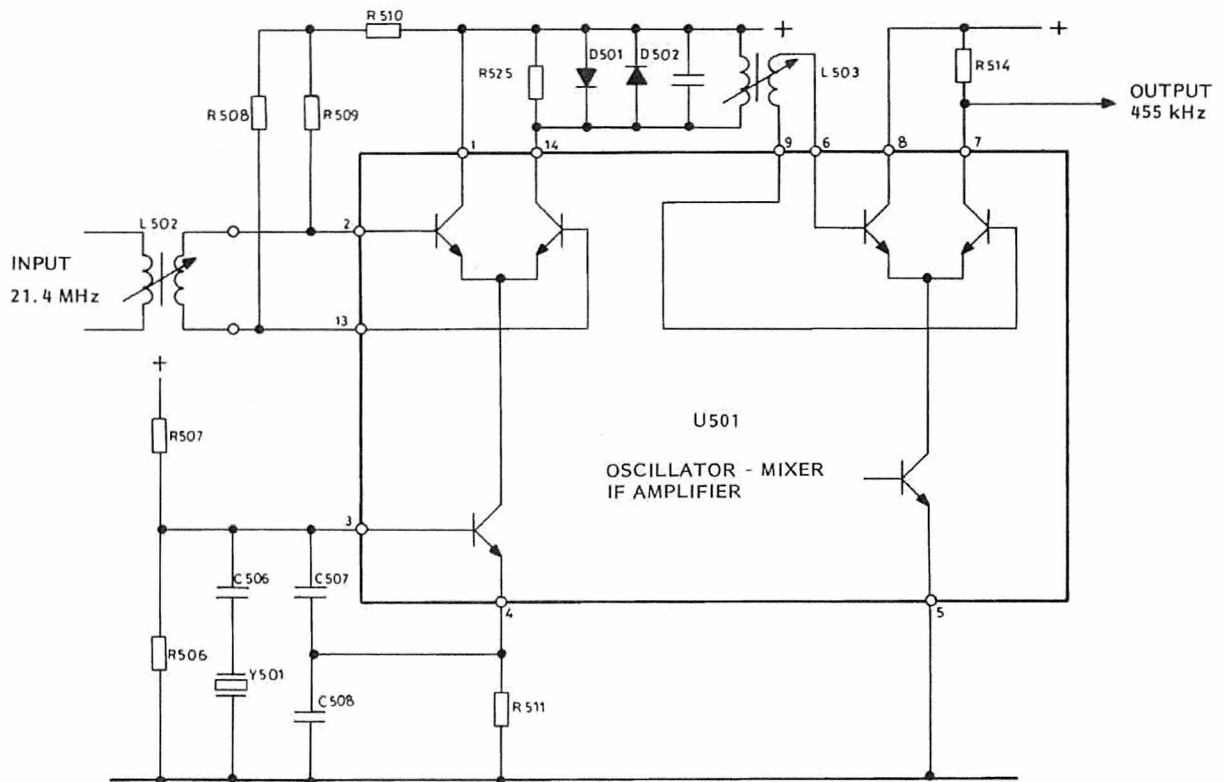

FIG. 1. SECOND OSCILLATOR , IF MIXER , AND IF AMPLIFIER

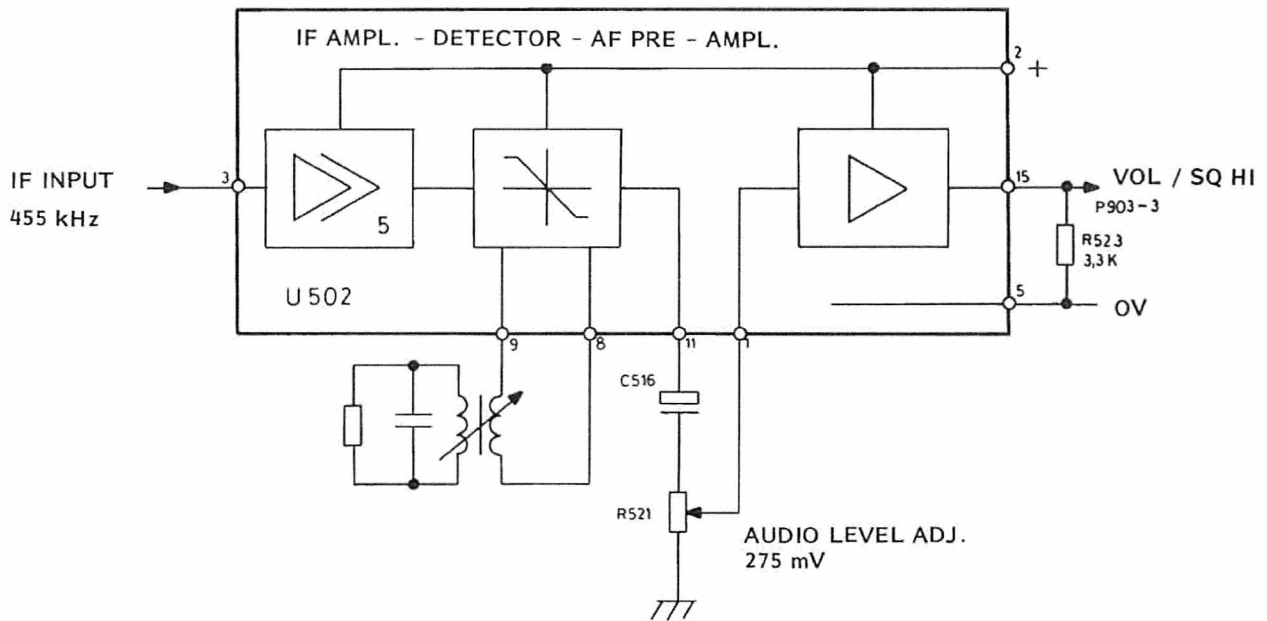

FIG. 2. IF AMPLIFIER , DETECTOR , AND AF PREAMPLIFIER

SQUELCH

The audio line signal (Vol/Sq - HI) is fed to a selective amplifier stage, where noise (frequencies around 7 kHz) is extracted from the audio signal. Via the squelch potentiometer R607, this signal reaches an expander stage which improves the level discrimination characteristics of the circuit. A passive voltage doubler circuit (D603-D604) with high source impedance performs the action of an average value rectifier. A Schmitt Trigger gives the necessary hysteresis and a well-defined output from the following buffer stage, Q605.

In the squelched condition and during transmissions this output is +1.5 V and mutes the audio power amplifier. The transmit indicator is part of the muting function.

A push button switch, S601, cancels the squelch function, when depressed, by grounding the base of Q601.

AUDIO CIRCUIT

In sets with Pilot tone option (CG), the audio line signal is fed to the Pilot tone board for filtering and back to the main board. In sets

without CG this path is bypassed and the audio line signal is fed directly to the passive de-emphasis network R629-C608 followed by the volume control.

The volume control potentiometer R630 is mounted directly on the RF board and protrudes through the front panel. The audio output amplifier U601 is a monolithic IC package capable of driving the loudspeaker at the desired power level. The output amplifier can be muted with a DC signal from the audio mute gate, which combines different logic signals to decide whether the amplifier should be active or not.

These inputs are:

- Regulated TX Voltage
- Squelch cancel
- Squelch signal

In sets equipped with Pilot tone and/or 5-tone sequential option, an RX mute function is routed from the option board to make the extra mute conditions possible.

The value of C610 in the feedback loop is chosen as the best compromise between battery ripple rejection and receiver squelch attack time.

The pilot lamp in the channel knob is supplied from A+, but controlled by the regulated 8.5 V via transistor Q968.

TRANSMITTER

The transmitter consists of a modulation processor, an exciter, and a power amplifier, all assembled on the main board along with the receiver.

The exciter contains an au audio processor, all frequency multiplier functions, and includes those stages operating at low enough power levels to avoid heat sinks.

The exciter output is at the carrier frequency when applied to the power amplifier.

The power amplifier boosts the signal to the proper level, and includes a low-pass filter for suppressing harmonics and a circuitry which permits adjustment of the operating power level. The PA low-pass filter connects to the antenna relay via a stripline on the board.

MODULATION PROCESSOR

The signal from the microphone load R901 on the FS board is applied to amplifier U101b. The transmitter audio frequency response is shaped by the feedback network R104-R103-C104.

The modulation limiting is obtained in the feedback network formed by D101, D102, R105, R106 and R107. The maximum permissible frequency deviation is set by a DEV potentiometer on the RF board.

Amplifier U101A is operated as an active low-pass splatter filter feeding the modulating input of the FM oscillator.

EXCITER

The exciter takes the synthesized signal, filters it to reduce spurious signals and amplifies it. Four amplifier stages (Q201-2-3-4), of which Q202 is a frequency tripler, and four filters (L204-5-8-9) are used in a narrow band design which limits the maximum frequency spread of the transmitter.

The exciter has four test points (TP201-2-3-4) for measurements and alignment.

POWER AMPLIFIER

The PA is constructed on the main board and employs two broadband untuned amplifier stages Q205, Q206. Two amplifier configurations are available providing options of power levels of 5 watts or 20 watts. A power control circuit is included to sense the output RF level and keep it constant with variations in temperature and supply voltage.

This circuit also limits the peak power to less than maximum, as specified by the authorities, while still maintaining the output as near maximum as possible.

The output power level can be set with a potentiometer, R215, over at least a 3:1 range. The transmitter delivers rated power into a 50-ohm load. A load SWR of 1.4:1 will result in more than 90% of the power being radiated. The transmitter will operate into a load with up to 3:1 SWR.

The power adjustment is achieved by controlling the supply voltage of power amplifier Q205 via transistor Q207. This series transistor is biased by a voltage generated by the feedback network C255, D210, Q210, Q209, Q208.

FREQUENCY SYNTHESIZER

The frequency synthesizer provides up to 12 channels and is built on a printed wiring board which mounts in the top section of the radio set. There are two versions of the board, a single channel board, FS5661, and multichannel board, FS5662.

The frequency of the single channel board is set by putting a binary code directly on the programmable divider input while the multichannel board uses a channel selector and

a Frequency Control unit, FC5001. The channel selector is mounted directly on the synthesizer board and protrudes through the front panel.

The Frequency Control unit FC5001 fits into a shield which is placed over the main section of the synthesizer board.

The Frequency Synthesizer board also carries all interconnections between the tone modules and the RF module, and it has two connectors at the rear for the accessories and the power supply cable.

SUPPLY VOLTAGE DISTRIBUTION SYSTEM

The battery voltage (A + BATT) enters the radio via two pins of the rear system connector to the synthesizer board. Both inputs are connected to reverse polarity protection diodes D901, D902. The ground lead comes through the same connector and is connected to chassis ground through a fusible printed wiring path which will open in case of the ground wire being accidentally connected to A+.

One battery input goes directly from the synthesizer board via a feed-through capacitor and a connector P907 to the transmitter PA stages. The other input feeds through J903 to the main board for two functions. One branch for the audio amplifier passes through an RC-ripple filter R638 - C618 and one of the ON/OFF switch sections S602. The other

section of the ON/OFF switch controls the V_B + to the voltage regulator U602 consisting of a monolithic regulator. The regulator output is fixed at 8.5 V by means of a factory adjusted resistor.

Regulated 8.5 V is switched to either the receiver or the transmitter by the antenna relay. The antenna relay is also supplied by the 8.5 V regulated.

The squelch circuit, the modulation processor, the Frequency Synthesizer and parts of the IF amplifier U502 are supplied directly from the continuous 8.5 V.

The receiver front-end, the 21.4 MHz IF stages and the second oscillator are supplied from 8.5 V RX.

The transmitter exciter is supplied from 8.5 V TX.

In sets with 5-tone sequential option or Pilot tone, the PTT (Push to talk) lead runs through the option board to provide for correct tone keying function.

WARNING

The transmitter PA transistors contain Beryllia which is poisonous when absorbed by the human body. Dissection, filing, or grinding of these transistors may be hazardous.

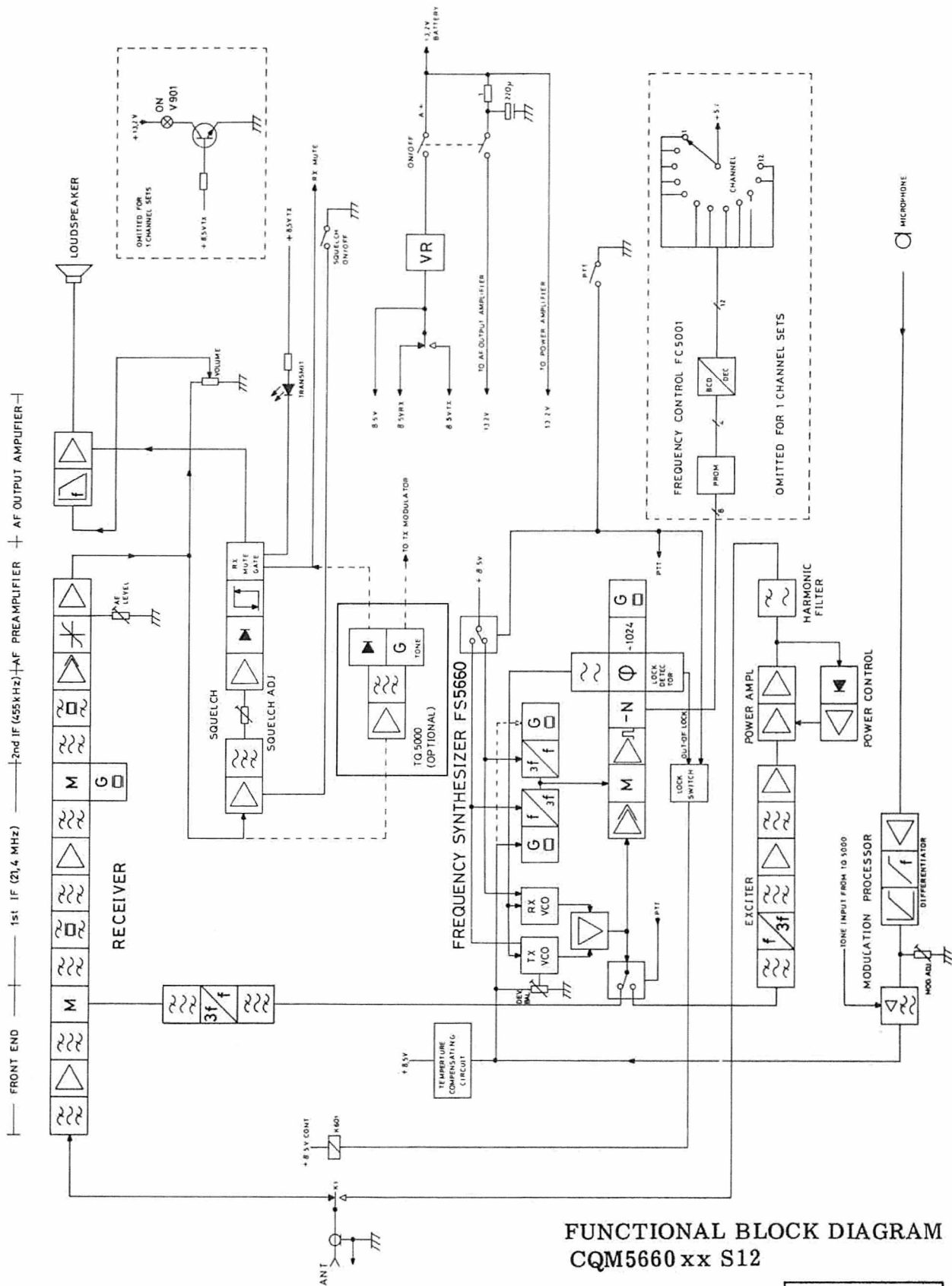

FUNCTIONAL BLOCK DIAGRAM
CQM5660xx S12

D402. 936

CHANNEL PROGRAMMING INSTRUCTIONS

CQM5660 S12

Programming of the PROM which contains the data for the channel frequencies will normally be part of the factory process, but it may also be field programmed.

The PROM programming unit must be approved by the PROM manufacturer, as for example (DATA I/O SYSTEM 17 or 19).

The programmer consists of the following items:

Programmer (DATA I/O SYSTEM 19)

Programming Pak, interchangeable

Socket adaptor

or universal programming pack.

DATA I/O UNIPAK (adaptable for more than 200 types of PROM devices).

To program a PROM the channel frequencies for all allocated channels and the channel spacing must be known.

It is recommended to complete a worksheet when calculating the PROM data.

It is also possible to use a computer to calculate the PROM data and Storno will be able to supply software programs for certain types of computers.

Operating instructions for the Programmer is supplied by the vendor.

WORKSHEET

For each PROM to be programmed a worksheet should be completed to calculate the input data for each channel.

The procedure for completing the worksheet is:

1. Complete list of receiver channel frequencies. (A).
2. Complete list of transmitter channel frequencies. (B).
3. Find highest (H) and lowest (L) receiving frequencies.
4. Find highest (H) and lowest (L) transmitting frequencies.
5. Select receiver mixer crystal frequency (C) from table 1. The highest and lowest receiver frequencies must be within the selected band.
6. Select transmitter mixer crystal frequency (D) from table 2. The highest and lowest transmitter frequencies must be within the selected band.
7. Note channel spacing and Reference frequency (F). See worksheet.
8. Use receiver formula to calculate " V_{DEC} " (divisor) for all receiver channels.
9. Use transmitter formula to calculate " V_{DEC} " (divisor) for all transmitter channels.
10. Check " V_{DEC} " for all channels to be between 256 and 511.
11. Use receiver crystal frequency and V_{DEC} to check for selfquieting frequencies, table 3.
12. In case of selfquieting select appropriate alternative and possibly recalculate "V".
13. Convert all " V_{DEC} " numbers to hexadecimal code. Refer to tabel 4.
14. Assign the hexadecimal codes to the corresponding channels and the PROM adresses.

After completing the worksheet the next steps are:

1. Enter correct Prom addresses and corresponding data (V_{HEX}) on the

Programmer (DATA I/O), refer to Programmer Operating Instructions.

2. Insert the channel knob stop (if needed) if less than 9 channels, refer to fig. 1.
3. In case of more than 8, but less than

12 channels are used, transmission on unauthorized channels must be avoided. This is done by burning the unused channel locations in the PROM with the highest channel HEX CODE.

CHANNEL STOP

LOWEST CH.	INSERT PIN BETWEEN	HIGHEST CH.	INSERT PIN BETWEEN
1	10 and 11	1	3 and 4
2	11 and 12	2	4 and 5
3	12 and 1	3	5 and 6
4	1 and 2	4	6 and 7
5	2 and 3	5	7 and 8
6	3 and 4	6	8 and 9
7	4 and 5	7	9 and 10
8	5 and 6	8	10 and 11
9	6 and 7	9	11 and 12
10	7 and 8	10	12 and 1
11	8 and 9	11	1 and 2
12	9 and 10	12	2 and 3

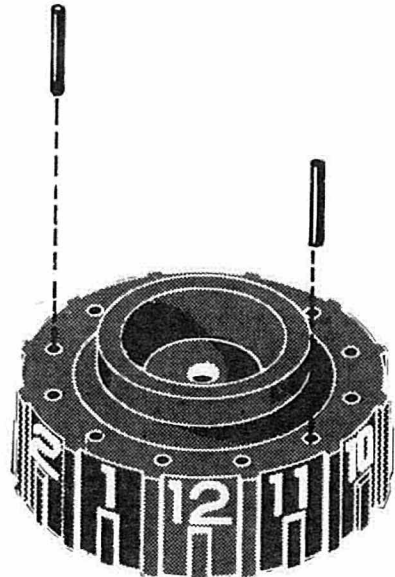

Note: If 8 channels are used insert only one PIN.
If more than 8 channels are used stop is not possible and no PINs are inserted.

Fig. 1. SETTING OF CHANNEL KNOB STOP.

RECOMMEND CRYSTAL FREQUENCIES

CQM5660 S12

CQM5662 FREQUENCY RANGE	CQM5663 FREQUENCY RANGE	RX CRYSTAL
418.6 - 424.9755	417.32 - 422.42	48.177777
421.1 - 427.4755	419.82 - 424.92	48.455555
423.6 - 429.9755	422.32 - 427.42	48.733333
426.1 - 432.4755	424.82 - 429.92	49.011111
428.6 - 434.9755	427.32 - 432.42	49.288888
431.1 - 437.4755	429.82 - 434.92	49.566666
433.6 - 439.9755	432.32 - 437.42	49.844444
436.1 - 442.4755	434.82 - 439.92	50.122222
438.6 - 444.9755	437.32 - 442.42	50.399999
441.1 - 447.4755	439.82 - 444.92	50.677777
443.6 - 449.9755	442.32 - 447.42	50.955555
446.1 - 452.4755	444.82 - 449.92	51.233333
441.4 - 447.7755	440.12 - 445.22	45.955555
443.9 - 450.2755	442.62 - 447.72	46.233333
446.4 - 452.7755	445.12 - 450.22	46.511111
448.9 - 455.2755	447.62 - 452.72	46.788888
451.4 - 457.7775	450.12 - 455.22	47.066666
453.9 - 460.2775	452.62 - 457.72	47.344444
456.4 - 462.7755	455.12 - 460.22	47.622222
458.9 - 465.2755	457.62 - 462.72	47.899999
461.4 - 467.7755	460.12 - 465.22	48.177777
463.9 - 470.2755	462.62 - 467.72	48.455555
466.4 - 472.7755	465.12 - 470.22	48.733333
468.9 - 475.2755	467.62 - 472.72	49.011111

TABLE 1. RECEIVER MIXER CRYSTAL FREQUENCY

RECOMMENDED CRYSTAL FREQUENCIES

CQM5660 S12

CQM5662 FREQUENCY RANGE	CQM5663 FREQUENCY RANGE	TX CRYSTAL
420.0 - 426.375	418.72 - 423.82	137.866666
422.5 - 428.875	421.22 - 426.32	138.7
425.0 - 431.375	423.72 - 428.82	139.533333
427.5 - 433.875	426.22 - 431.32	140.366666
430.0 - 436.375	428.72 - 433.82	141.2
432.5 - 438.875	431.22 - 436.32	142.033333
435.0 - 441.375	433.72 - 438.82	142.866666
437.5 - 443.875	436.22 - 441.32	143.7
440.0 - 446.375	438.72 - 443.82	144.533333
442.5 - 448.875	441.22 - 446.32	145.366666
445.0 - 451.375	443.72 - 448.82	146.2
447.5 - 453.875	446.22 - 451.32	147.033333
450.0 - 456.375	448.72 - 453.82	147.866666
452.5 - 458.875	451.22 - 456.32	148.7
455.0 - 461.375	453.72 - 458.82	149.533333
457.5 - 463.875	456.22 - 461.32	150.366666
460.0 - 466.375	458.72 - 463.82	151.2
462.5 - 468.875	461.22 - 466.32	152.033333
465.0 - 471.375	463.72 - 468.82	152.866666
467.5 - 473.875	466.22 - 471.32	153.7

TABLE 2. TRANSMITTER MIXER CRYSTAL FREQUENCY

SELFQUIETING FREQUENCIES

CQM5662

RECEIVER CRYSTAL FREQUENCY, MHz	V DEC	USE ALTERNATIVE ⁺
All crystal frequencies	428	1
48.177	265	2
48.177	274	4
48.733	416	4
48.733	459	4
49.844	466	2
50.122	366	2
50.399	266	2
50.399	397	4
47.622	465	2
47.899	328	2

⁺refer to worksheet

TABLE 3A. SELFQUIETING FREQUENCIES

SELFQUIETING FREQUENCIES

CQM5663

RECEIVER CRYSTAL FREQUENCY, MHz	V DEC	USE ALTERNATIVE ⁺
48.177	278	4
48.177	286	2
48.177	331	4
49.566	290	4
50.122	458	4
50.122	503	4
50.399	333	2
50.399	378	2
45.955	284	4
46.511	374	2
46.788	375	4
47.899	399	4
47.899	411	4
47.899	456	2
48.177	274	4
48.177	286	4
48.177	331	4
48.177	420	2
48.733	390	4
48.733	394	2
49.011	265	4

⁺refer to worksheet

TABLE 3B. SELFQUIETING FREQUENCIES

Least Significant Digit (LSD) of Hex Code

	0	1	2	3	4	5	6	7	8	9	A	B	C	D	E	F
0	256	257	258	259	260	261	262	263	264	265	266	267	268	269	270	271
1	272	273	274	275	276	277	278	279	280	281	282	283	284	285	286	287
2	288	289	290	291	292	293	294	295	296	297	298	299	300	301	302	303
3	304	305	306	307	308	309	310	311	312	313	314	315	316	317	318	319
4	320	321	322	323	324	325	326	327	328	329	330	331	332	333	334	335
5	336	337	338	339	340	341	342	343	344	345	346	347	348	349	350	351
6	352	353	354	355	356	357	358	359	360	361	362	363	364	365	366	367
7	368	369	370	371	372	373	374	375	376	377	378	379	380	381	382	383
8	384	385	386	387	388	389	390	391	392	393	394	395	396	397	398	399
9	400	401	402	403	404	405	406	407	408	409	410	411	412	413	414	415
A	416	417	418	419	420	421	422	423	424	425	426	427	428	429	430	431
B	432	433	434	435	436	437	438	439	440	441	442	443	444	445	446	447
C	448	449	450	451	452	453	454	455	456	457	458	459	460	461	462	463
D	464	465	466	467	468	469	470	471	472	473	474	475	476	477	478	479
E	480	481	482	483	484	485	486	487	488	489	490	491	492	493	494	495
F	496	497	498	499	500	501	502	503	504	505	506	507	508	509	510	511

Most Significant Digit of Hex Code

"V_{DEC}" Numbers.



Example "V_{DEC}" = 345 equals to hex code 59.
 "V_{DEC}" = 469 equals to hex code D5.

Table 4.
 "V" Number to hex code conversion table.

FOR CQM5660 S12

Customer:

RECEIVER						TRANSMITTER					
CHAN-NEL	A FREQUENCY MHz	L H	V DEC	V HEX	PROM ADDRESS (HEX)	B FREQUENCY MHz	L H	V DEC	V HEX	PROM ADDRESS (HEX)	
1					00					10	
2					01					11	
3					02					12	
4					03					13	
5					04					14	
6					05					15	
7					06					16	
8					07					17	
9					08					18	
10					09					19	
11					0A					1A	
12					0B					1B	

RECEIVER MIXER CRYSTAL FREQ. (Y702): C= _____

420 - 450 MHz: $V_{DEC} = \frac{(A + 21.4) - (C \times 9)}{3 \times F}$

440 - 470 MHz: $V_{DEC} = \frac{(A - 21.4) - (C \times 9)}{3 \times F}$

TRANSMITTER MIXER CRYSTAL FREQ. (Y701) D= _____

FORMULA: $V_{DEC} = \frac{B - (D \times 9)}{3 \times F}$

CHANNEL SPACING:	REFERENCE CRYSTAL (Y703):	REFERENCE FREQUENCY:
20 kHz	6.8266 MHz	F= 0.006666
25 kHz	8.5333 MHz	F= 0.008333
12.5 kHz	4.26667 MHz	F= 0.004166

LIST OF REFERENCE CRYSTALS (Y703)

ALTERNATIVE SOLUTIONS IF THE RECEIVER IS SELFQUIETING:

MODE	FREQUENCY, MHz	PART No.
Standard 5662	8.5333333	19J706361P3
Standard 5663	6.8266666	19J706361P4
Standard 5664	4.26667	19J706361P5

1. SELECT ANOTHER RX MIXER CRYSTAL FREQUENCY
2. SELECT HIGH INJECTION FREQUENCY FOR 2nd OSCILLATOR
Y501= 21.85500 MHz INSTEAD OF 20.945000 MHz
3. USE SLIGHTLY OFFSET REFERENCE CRYSTAL
4. WEAK QUIETING; NO ALTERNATIVE REQUIRED

ADJUSTMENT PROCEDURE

CQM5660 S12

This adjustment procedure applies to the following radiotelephone types:

CQM5662 S12 30/25 kHz Channel spacing
CQM5663 S12 20 kHz Channel spacing

Before making adjustments to the radiotelephone transmitter/receiver, read the type label and note the channel frequencies.

Check all straps according to the notes on the diagrams. Also check the selective calling tone equipment, if any, against the coding instructions; refer to description of tone equipment.

All screens must be in place and properly secured during the adjustments.

MEASURING INSTRUMENTS

The following list contains instruments necessary for adjusting the radiotelephone and checking its performance characteristics:

DC Voltmeter	$R_{in} \geq 1$ Mohm
AC Voltmeter	$Z_{in} > 1$ Mohm//50 pF
Multimeter	$R_i \geq 20$ Kohm/Volt
Distortion meter	e. g. Storno E11c
RF Watt meter	25 W/50 ohm/420-470 MHz
Deviation meter	420-470 MHz
RF generator	$Z_{out} = 50$ ohm; 420-470 MHz
21.4 MHz signal generator	e. g. Storno TS-G21B

Frequency counter with attenuator	$Z_{in} = 50$ ohm; sensitivity 100 mV at 470 MHz
RF diode probe	Storno 95.0089-00
RF coaxial probe	Storno 95.0179-00
DC power supply	10.8 V - 16.6 V; 6A
Oscilloscope	0 - 5 MHz min.

MISCELLANEOUS

4 ohm/3 W resistor	3 x Storno code 82.5026-00
22 uF/40 V electrolytic capacitor	Storno code 73.5107-00
Connector, 11-pin house	Storno code 41.5543-00
Connector, 8-pin house	Storno code 41.5542-00
Pins for connectors	Storno code 41.5551-00
Trimming tools	

The following tables show the frequency ranges of the CQM5660 S12 radiotelephone signals:

SIGNAL	FREQUENCY MHz
TX VCO	140 - 156
TX crystal	45 - 50
TX crystal multiplication	x3
RX VCO	139 - 157
RX crystal	47 - 50 (420 - 450) 45 - 48 (440 - 470)
RX crystal multiplication	x3

Table 1.

Channel spacing kHz	Reference Crystal MHz	Min. Divider input frequency MHz	Max. Divider input frequency MHz	Reference frequency kHz
20	6.8266	1.7066	3.4066	6.666
30 or 25 ¹⁾	5.8533	2.1333	4.2583	8.333

Table 2 ¹⁾ Two steps per channel

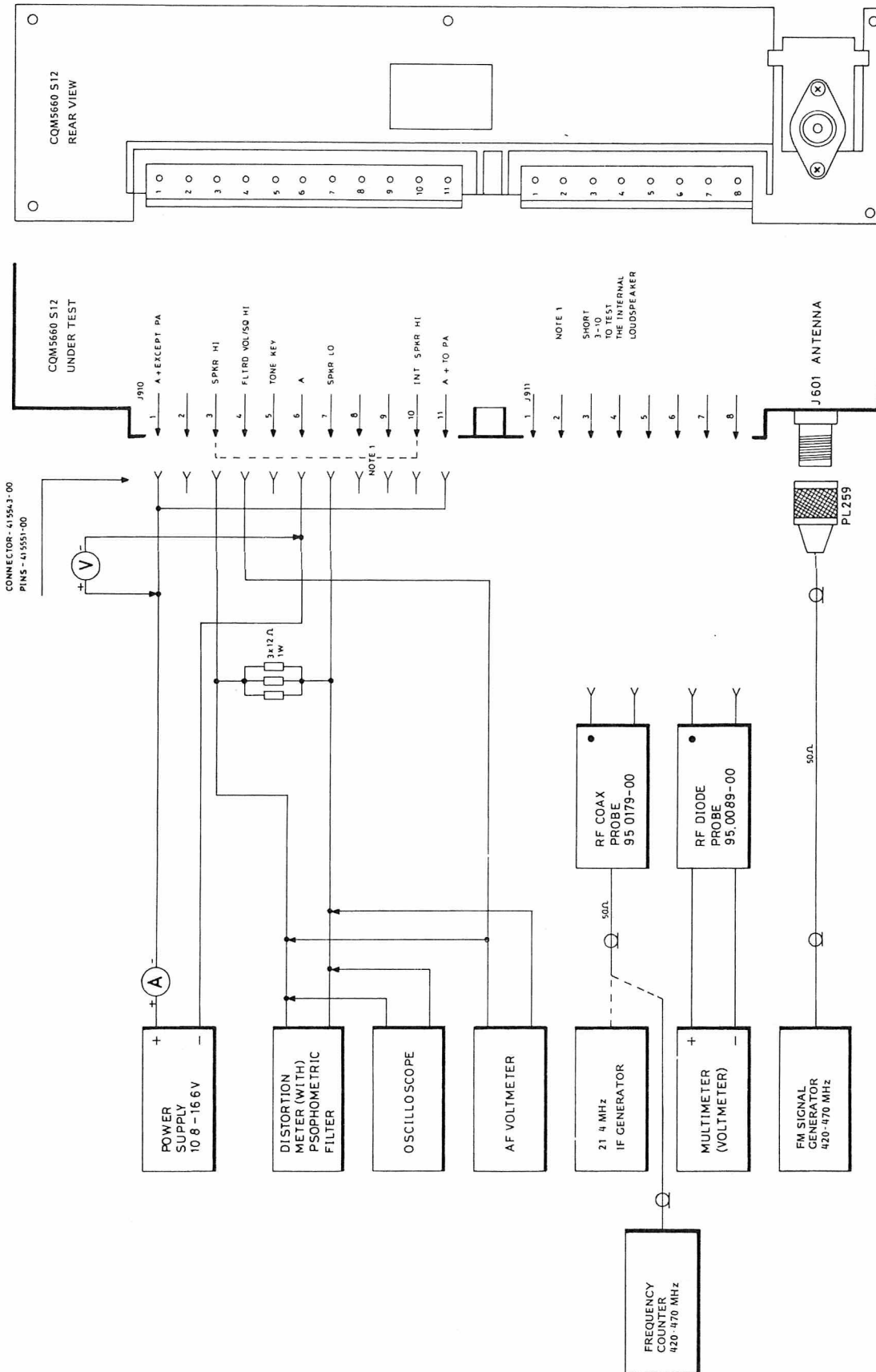

RECEIVER TEST SET-UP

CQM5660 S12

D402.935

RECEIVER ADJUSTMENT

CHECKING 8.5 V REGULATED SUPPLY

Turn the power supply ON and set the voltage to 13.2 V. Set the power supply current limiter to 1 A.

Turn the radiotelephone ON by depressing the ON/OFF button. Note the light in the Channel selector, if any, is on.

Depress the Squelch button.

Set the volume control to minimum.

Connect the DC voltmeter to J901 pin 3 and read the Voltage.

Requirement: 8.5 V \pm 0.15 V

If the requirement is not fulfilled check resistor R636 against the colour code of U602.

U602 colour code	R636 Value
Brown	omit
Red	270
Orange	100
Yellow	47
Green	22
Blue	6.8

Adjust the power supply voltage to 16.6 V and read the 8.5 V regulated. Compare the change in the 8.5 Volt regulated to the value obtained at 13.2 V.

Requirement: \leq 50 mV

Repeat the procedure with the power supply adjusted for 10.8 V

FREQUENCY SYNTHESIZER ALIGNMENT

Check the PROM U801, the TX mixer crystal, the RX mixer crystal, and the reference crystal and verify the frequencies and PROM codes.

Mixer crystal output

Connect RF diode probe 95.0089-00 with multimeter to test point TP701. (1 V range).

Adjust L711 for maximum deflection on the multimeter.

Adjust L707 for maximum deflection on the multimeter.

Requirement: 45 mV \pm 15 mV

(corresponding to -10 dBm to -4 dBm).

Note: Be careful not to resonate L707 to the false harmonics. If in doubt consult table 1 or check the crystal oscillator output with a spectrum analyzer.

Receiver VCO

Connect the oscilloscope to test point TP706.

The oscilloscope measures the synthesizer's lock signal which is +8 volts with very narrow negative going pulses when in locked position. Unlocked condition is indicated by a variable duty signal or logic "low".

Typical trace for locked condition

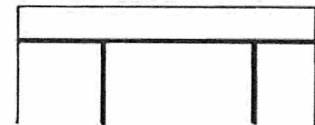

The pulse repetition rate is 10 or 12.5 kHz corresponding to the channel spacing respectively. Select the channel whose frequency is closest to the center frequency.

Adjust C745 for as narrow pulses as possible.

Connect the multimeter to test point TP703.

Adjust C745 for 4.0 volt on the multimeter.

If the radio has more than one channel adjust C745 so that the multimeter reading for all channels are evenly distributed around 4.0 volt. The high channel frequency shall give a voltage reading above 4.0 volt equal to the low channel reading below 4.0 volt.

Example:

High channel reading: 4.8 volt (4.0 + 0.8)

Center channel reading: 4.0 volts

Low channel reading: 3.2 volt (4.0 - 0.8)

The deviation of the voltage reading from 4.0 volts depends on the spread of the high and low channel.

Mixer Crystal Frequency

Connect coax probe 95.0179-00 to test point TP701.

Connect the frequency counter to the probe and read the frequency.

$$f = f_x \times 3 \quad (f_x = \text{crystal frequency})$$

Adjust L711 to the calculated frequency.

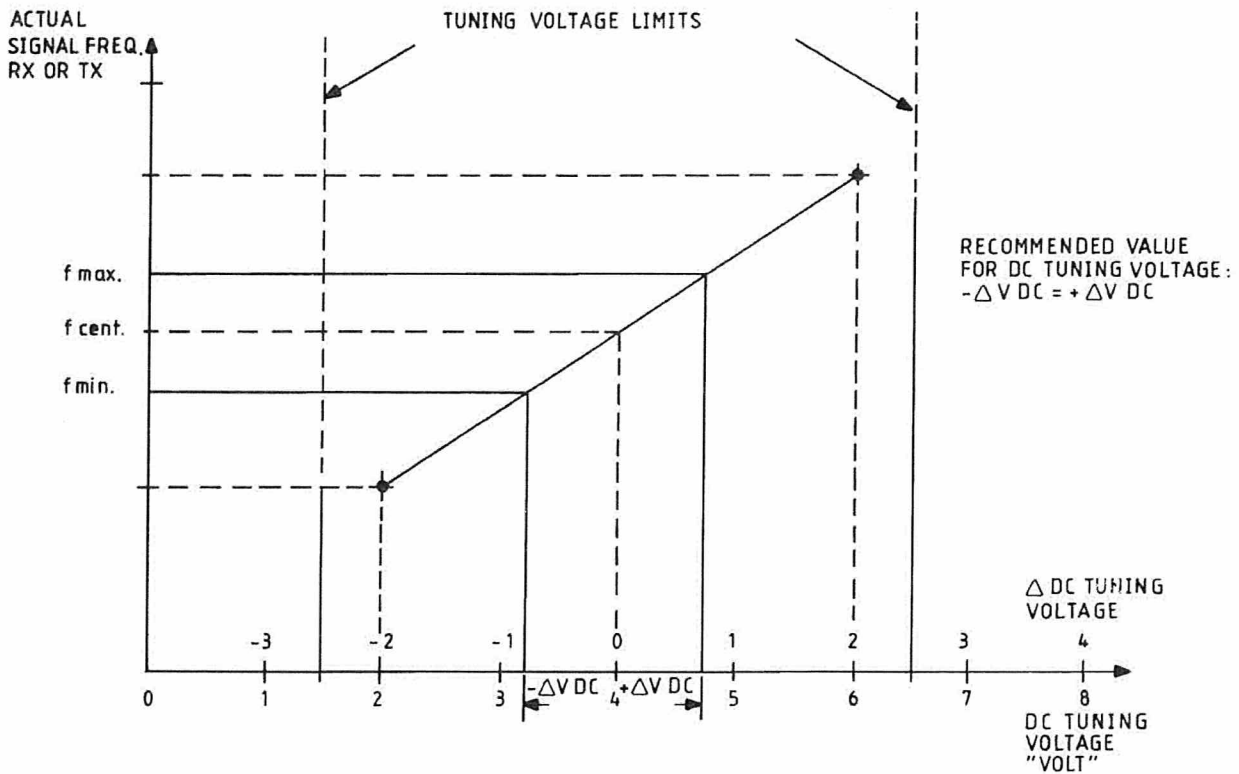

Requirement: $f \pm 0.3 \text{ ppm at } 25^{\circ}\text{C.}$
 $\text{ppm} = \text{parts per million} = 10^{-6}$

Injection Frequency

Connect coax probe 95.0179-00 to test point TP401.

Connect the frequency counter to the probe.
 Calculate the injection frequency for all channels.

$$f_{inj} = f_{ant} - 21.4 \text{ (MHz)}$$

Select, one by one, the channels and read the injection frequency.

Requirement: $F_{inj} \pm 0.2 \text{ ppm}$

IF AMPLIFIERS

Connect a 21.4 MHz signal generator to TP401 via coax probe 95.0179-00.

Connect RF diode probe 95.0089-00 with multimeter to test point TP501. (50 uA range).

During adjustment the RF generator output must be kept low enough to prevent limiting

in the IF stages, i.e. a maximum reading of 50 uA on the multimeter.

Adjust coils L503, L502, L501, and L406, in that order, for maximum deflection on the multimeter.

FRONT-END

Connect the RF probe 95.0089-00 and the multimeter to test point TP501. (50 uA range).
 Connect an unmodulated RF generator to the antenna connector, J601.

Set the generator frequency to the receiver frequency.

Adjust the generator output to produce a deflection on the multimeter, i.e. a maximum reading of 50 uA on the multimeter.

Adjust L401 and L402 for maximum deflection.

Detune L406: Adjust L405 and L407 for maximum deflection on the multimeter.

Adjust L406 for maximum deflection.

Readjust L401 and L402 for maximum deflection.

Remove the RF diode probe.

Standard Test condition:

Connect the RF generator to antenna connector and adjust the output to 1 mV e. m. f. Modulate the RF generator with 1000 Hz to 60% of Δf max.

CQM5662 S12 ± 3 kHz

CQM5663 S12 ± 2.4 kHz

Connect a 4 ohm/3 W resistor load to connector J910/3-7 (SPKR HI-SPKR LO).

Connect an AF voltmeter to J910/4-7 (FLTD VOL SPKR LO).

IF DEMODULATOR

Turn R521 halfway up.

Adjust L504 for maximum reading on the AF voltmeter.

Connect a distortion meter and AF voltmeter across the 4 ohm resistor. (if Storno E11c distortion meter is used switch the function to AF voltmeter).

Adjust the volume control for approx. 2 V across the load.

Adjust L501 and L406 for minimum distortion. The demodulated signal may be monitored on an oscilloscope connected in parallel with the distortion meter.

Connect the AF voltmeter and distortion meter to J910/4-7 (FLTD VOL - SPKR LO).

Adjust R521 for a reading of 275 mV on the AF voltmeter.

Requirement: 275 mV ± 5 mV.

Read the distortion.

Typical Total Harmonic Distortion (THD) will be less than 5%.

RECEIVER SENSITIVITY

EIA or CEPT method may be used.

Method of measurement CEPT

The purpose of the measurement is to define the ratio of one condition to another.

The first condition is the one where a modulated RF-signal drives the receiver into full limiting. The audio output is measured with the distortion meter (in the CAL position) and, disregarding the amplitude of the audio, this is adjusted to read 100% on the meter scale; this is our reference condition consisting of signal +noise +distortion, where 'signal' is the modulation of the RF, 'noise' is the lowest possible amount achieved from that particular receiver, when receiving a strong carrier, and 'distortion' is the modulation being slightly distorted in passing through the receiver.

The second condition is the one where the signal (modulation) is removed with a notch filter and the RF-signal is lowered in amplitude until the remaining noise and distortion increases to 20 dB below the first condition, as read on the distortion meter scale. This corresponds to a reading of 10%, 10 being 20 dB below 100, which was our reference condition.

In practice our first condition is achieved by feeding a minimum of 1000 uV of RF-signal modulated with 1000 Hz at 60% Δf max. to the receiver.

The audio output (which must be at least 100% of the receiver's audio rating) is measured through the psophometric filter, with the distortion meter in position CAL and adjusted with potentiometer ADJ. FSD. to a reading of 100.

The notch filter is then inserted in series with the audio by pressing one of the buttons marked in %. The meter needle immediately drops to indicate a low value, this being the receiver's inherent audio distortion.

By backing off the attenuator of the RF generator, thereby lowering the RF input to the receiver, the noise will eventually increase; the attenuator is now adjusted for a 10% reading on the distortion meter scale.

At this stage it must be ensured that the increased noise and the signal (with the notch filter switched out while checking) still equals 100 on the meter scale.

The RF-generator's calibrated attenuator now shows the value of RF-signal required to achieve a 20 dB ratio between signal + noise + distortion and noise + distortion, i. e. 20 dB SINAD sensitivity.

EIA Method

EIA (Electronic Industries Association)

Standard, definition:

The SINAD sensitivity of a receiver is the minimum input signal that will provide at least 50% of the receiver's rated audio power with 12 dB signal + noise + distortion to noise + distortion.

The EIA method differs from CEPT by omitting the psophometric filter, adjusting the RF generator for $2/3 \times \Delta f_{max.}$, and measure the distortion at 50% of the receiver's rated AF power. The SINAD sensitivity is measured as a 12 dB ratio between signal + noise + distortion and noise + distortion, which corresponds to a reading of 25% noise + distortion.

ADJUSTING THE SENSITIVITY

Lower the RF generator output to obtain 20 dB SINAD (10% THD as measured with the

distortion meter). Readjust L402 for the best SINAD value, e. i. lowest generator output for 10% THD.

MEASURING 20 dB SINAD (CEPT)

Adjust the volume control for 2.45 V (1.5 W/4 ohm) as measured with an AF voltmeter across the load.

Adjust the RF generator output to obtain 20 dB SINAD condition.

Read the 20 dB SINAD sensitivity (e. m. f.) Requirement: $\leq 1.0 \mu V$.

The sensitivity should be measured on all channels, if more than one.

MEASURING 12 dB SINAD (EIA)

Adjust the volume control for 2.45 V as measured with an AF voltmeter across the load.

Adjust the RF generator to obtain 12 dB SINAD condition.

Read the 12 dB SINAD sensitivity.

Requirement: $\leq 0.4 \mu V$ ($\frac{1}{2}$ e. m. f.)

The sensitivity should be measured on all channels, if more than one.

AUDIO FREQUENCY RESPONSE

Set the signal generator to Standard Test Condition.

Adjust the volume control for 0.82 V across the load. (4 ohm across (SPKR HI - LO)).

At 13.2 V supply, $\Delta F = 60\% \Delta F_{max}$ and 1000 Hz measure the output voltage according to the following table:

	Frequency	Level	Tol.
Type CQM5662 S12	300 Hz	+9 dB	+1 dB/-3 dB
	1000 Hz	0 dB	
	3000 Hz	-9.5 dB	+1 dB/-3 dB
Type CQM5663 S12	300 Hz	+10.5 dB	+1.5 dB/-3 dB
	400 Hz	+8 dB	+1.5 dB/-1.5 dB
	1000 Hz	0 dB	
	2700 Hz	-8.6 dB	+1.5 dB/-1.5 dB
	3000 Hz	-9.5 dB	+1.5 dB/-3 dB
	6000 Hz	<-20 dB	

SELF QUIETING CHECK

Internal oscillators, dividers and the harmonic frequencies hereof, may cause self quieting of the receiver if a mixer product falls in the RF or IF pass band.

For proper operation of the squelch all channels must be checked for the self quieting phenomenon.

Connect the RF generator to the antenna connector. Reduce the RF output to 0.

Set the frequency outside the 420 - 470 MHz band.

Alternatively, an attenuator (50 ohm) may be connected to the antenna connector.

Connect an AF voltmeter across the 4 ohm speaker load.

Adjust the volume control for 774 mV (0 dBm) as read on the AF voltmeter.

Select, in turn, all allocated channels.

The reading on the AF voltmeter shall not on any selected channel decline more than 6 dB.

Requirement: Quieting ≤ 6 dB.

AF POWER OUTPUT

Adjust the RF signal generator to Standard Test Condition.

Set the supply voltage to 13.2 V.

Adjust the volume control for 3 W output (3.46 V across the 4 ohm load).

Measure the distortion (THD).

Requirement: THD $\leq 5\%$.

SQUELCH

Release the squelch cancel button.

Adjust potentiometer R607 squelch adj. to open the receiver for an RF input signal corresponding to 8-10 dB SINAD.

The final squelch adjustment must not be set on a channel that has shown a minor degree of selfquieting.

CURRENT CONSUMPTION

Measure the current consumption at 13.2 V.

Requirements

Condition	Current consumption
Standby	≤ 400 mA
Receive 2 W AF ~ 2.83 V r.m.s. across 4 ohm.	≤ 750 mA

For sets with selective calling facilities add current consumption of the tone unit to the figures above.

TRANSMITTER ADJUSTMENT

Adjust the power supply voltage to 13.2 V and set current limiter as follows:

20 W transmitter: 6A

5 W transmitter: 4A

Refer to Receiver Alignment for measuring 8.5 V regulated supply.

Preset all transmitter tuning slugs, L151, L153, L201, L202, L204, and L205 to be flush with the coil form top.

Connect a multimeter (2.5 volt range) to test point TP201.

Turn the power control potentiometer, R221, to minimum, anticlockwise (CCW).

Connect a Wattmeter, (25 W) to the antenna connector, J601.

FREQUENCY SYNTHESIZER ALIGNMENT

Check the PROM U801, the TX mixer crystal, the RX mixer crystal, and the reference crystal and verify the frequencies and the prom codes.

Mixer crystal output

Connect RF probe 95.0089-00 with multimeter to test point TP701 (1 V range).

Key the transmitter.

Adjust L701 for maximum deflection on the multimeter.

Adjust L704 for maximum deflection on the multimeter.

Requirement:

40 mV \pm 15 mV

(corresponding to -10 dBm to -4 dBm)

Note: Be careful not to resonate L704 to the false harmonics. If in doubt consult table 1 or check the crystal oscillator output with a spectrum analyzer.

Transmitter VCO

Connect the oscilloscope to test point TP706. The oscilloscope measures the synthesizer's lock signal which is +8 volts with very narrow negative going pulses when in locked position. Unlocked condition is indicated by a variable duty signal or logic "low".

Typical trace for locked condition

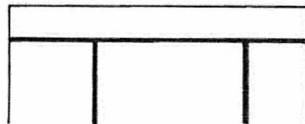

The pulse repetition rate is 10 or 12.5 kHz corresponding to the channel spacing respectively. Select the channel whose frequency is closest to the center frequency. Adjust C745 for as narrow pulses as possible. Connect the multimeter to test point TP703. Adjust C745 for 4.0 volt on the multimeter.

If the radio has more than one channel adjust C745 so that the multimeter reading for all channels are evenly distributed around 4.0 volt. The high channel frequency shall give a voltage reading above 4.0 volt equal to the low channel reading below 4.0 volt.

Example:

High channel reading: 5.1 volt (4.0 + 1.1)

Center channel reading: 4.0 volts

Low channel reading: 2.9 volt (4.0 - 1.1)

The deviation of the voltage reading from 4.0 volts depends on the spread of the high and low channel.

Mixer Crystal Frequency

Connect coax probe 95.0179-00 to test point TP701.

Connect the frequency counter to the probe, key the transmitter and read the frequency.

$f = f_x \times 3$ (f_x = crystal frequency).

Adjust L701 to the calculated frequency.

Requirement: $f \pm 0.3$ ppm at 25°C.

ppm= parts per million= 10^{-6} .

Synthesizer Output Level

Connect a multimeter, 2.5 V range, to test point TP201. Key the transmitter.

Adjust L153 for maximum deflection on the multimeter, typical more than 0.75 V.

EXCITER

Connect a multimeter (1.0 V range) to test point TP201.

Adjust L203 for minimum deflection. The dip is small.

Connect the multimeter, (1 V range) to test point TP202.

Adjust L204 for maximum deflection on the multimeter, typical 0.7 V.

Repeat the adjustments of L203, L153, and L151 (L921-L926) until no further improvements is obtainable.

Adjust C213 for minimum reading. The dip is small.

Connect the multimeter, 1 volt range, to test point TP203.

Adjust C215 for maximum reading on the multimeter, typical 0.5 V.

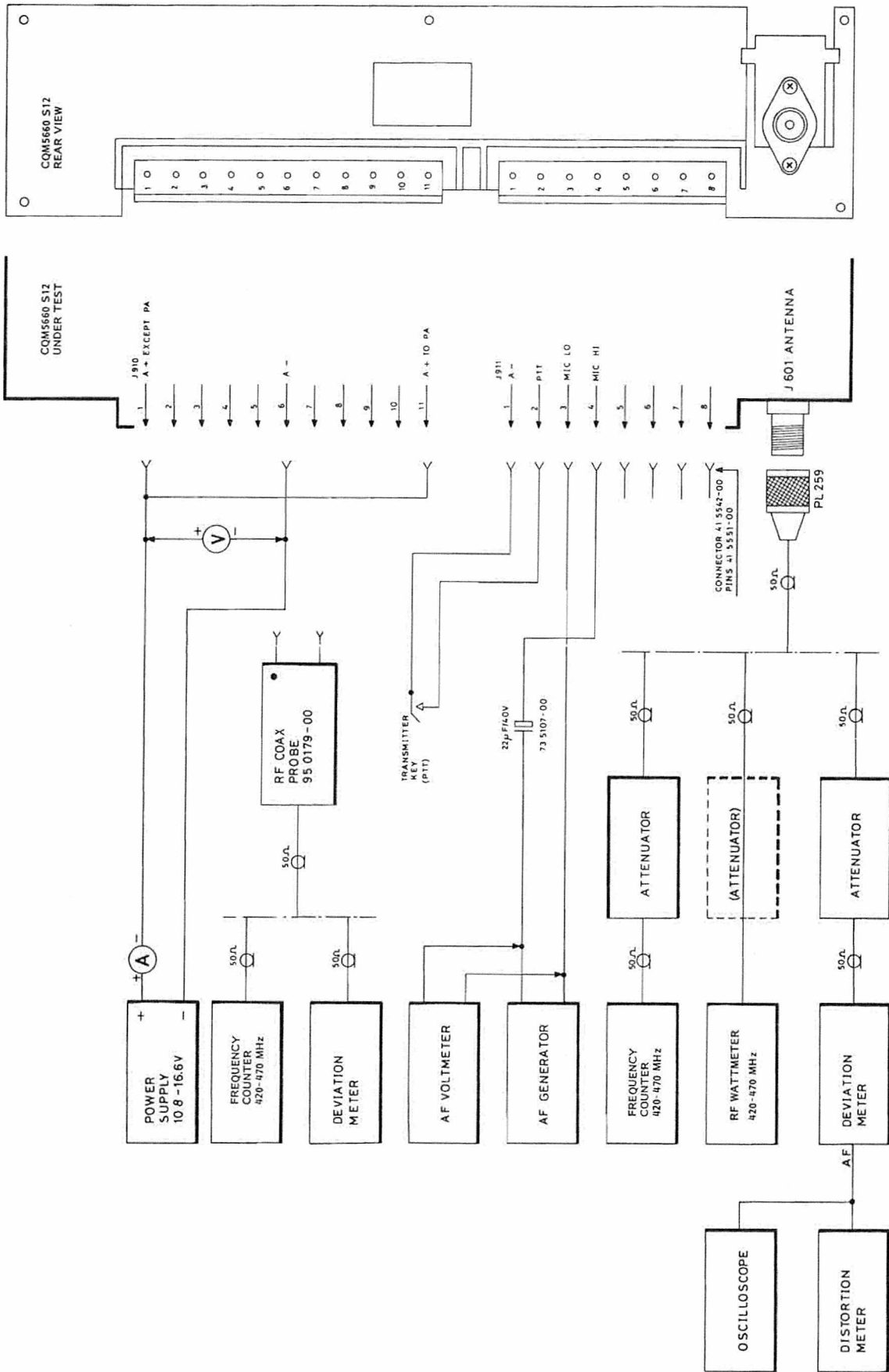

TRANSMITTER TEST SET-UP
CQM5660 S12

D402.937

Repeat the adjustment of C213 and L204 until no further improvement is obtainable.
Adjust C221 minimum deflection. The dip is small and careful tuning is required.
Connect the multimeter, 10 volt range, to the RF probe.
Connect RF diode probe 95.0089-00 to TP204.
Adjust C221 and C223 for maximum deflection (typical 4.0 V).
Adjust the PA power control, R215, for rated transmitter power, 5 W or 20 W.

EXCITER, FINE ADJUSTMENT

Connect the multimeter to test point TP201.
Readjust L153 for maximum reading.
Connect the multimeter to test point TP202.
Peak L203 and L204 for maximum reading.
Connect the multimeter to test point TP203.
Connect C213 and C215 for maximum reading.
Connect the 95.0089-00 RF probe and multimeter to TP204.
Adjust C221 and C223 for maximum reading.

TYPICAL TEST POINT READINGS

TP201: 0.2 V
TP202: 0.7 V
TP203: 0.5 V
TP204: 4.0 V

TRANSMITTER FREQUENCY ADJUSTMENT

Connect a frequency counter through a suitable attenuator to the antenna connector J601.

Key the transmitter.
Select one by one, the channels and read their frequencies.
Adjust L701 for best frequency tracking on all channels.

Requirement: $F = F_{\text{ant}} \pm 0.2 \text{ ppm}$,
ppm = parts per million = 10^{-6}

RF POWER OUTPUT, CURRENT CONSUMPTION, AND POWER CONTROL

Connect the Watt meter to the antenna connector, J601.
Increase the supply voltage to 13.2 V. The voltage is measured directly at the input connector J910.
Readjust the PA power control, R221, for rated transmitter power (P), 20 W or 5 W.
Requirement: $P_{\text{nom}} \pm 0.2 \text{ dB}$.
Measure the RF power output at 16 V, 13.2 V and 10.8 V.

Requirements (20 W):

Voltage	Power	Current
16 V	$\leq 25 \text{ W}$ (ref)	5.4 A
13.2 V	20 W	5.4 A
10.8 V	$\geq 12 \text{ W}$	5.4 A

Requirements (5 W):

Voltage	Power	Current
16 V	$\leq 6.5 \text{ W}$	1.7 A
13.2 V	5 W	1.7 A
10.8 V	$\geq 3.5 \text{ W}$	1.7 A

MODULATION ADJUSTMENT

Set the power supply voltage to 13.2 V.
Select the channel having the highest frequency. Set R116 to mid-position.
Connect coax probe 95.0179-00 to test point TP701.
Connect a deviation meter to the coax probe.

Connect a distortion meter and oscilloscope to the deviation meter output.
Connect a AF generator and an AF Voltmeter to the microphone input via a 22 uF capacitor; refer to test setup.
Set the AF generator to 1000 Hz.

Adjust the AF generator output to 1 V r. m. s. This voltage is approx. 20 dB above the nominal modulation input level (60% Δf max) to ensure full limiting in the modulation processor.

Note the deviation read at TP701.

Connect the deviation meter to test point TP702.

Adjust R752 (Dev. Bal.) for same deviation as measured at TP701.

Connect the deviation meter through an attenuator to the antenna connector, J601.

Connect a distortion meter and oscilloscope to the deviation meter output.

Connect an AF generator and an AF Voltmeter to the microphone input via a 22 μ F capacitor; refer to test setup.

Set the AF generator to 1000 Hz.

Adjust the AF generator output to 1 V r. m. s. This voltage is approx. 20 dB above the nominal modulation input level (60% Δf max) to ensure full limiting in the modulation processor.

Find the AF frequency between 200 Hz and 3000 Hz giving the greatest frequency deviation as read on the deviation meter with the transmitter keyed.

Check the maximum deviation for both positive and negative deviation polarity. At that audio frequency set the maximum frequency deviation Δf max with R116.

Type	Channel spacing	Δf max
CQM5662 S12	30/25 kHz	± 5 kHz
CQM5663 S12	20 kHz	± 4 kHz

Requirement

Difference between + and - deviation: $\leq 10\%$

MODULATION SENSITIVITY AND MODULATION DISTORTION

Set the AF generator frequency to 1000 Hz
Adjust the generator output until 60% of Δf max is obtained on the deviation meter.

CQM5662 S12 : ± 3.0 kHz

CQM5663 S12 : ± 2.4 kHz

Read the AF generator output and measure the modulation distortion on the audio output of the deviation meter.

Requirements:

Modulating signal: 75 mV ± 3 dB

Distortion: $\leq 7\%$
(measured without deemphasis)

MODULATION FREQUENCY RESPONSE

Set the AF generator to 1000 Hz.

Reduce the AF generator output until a deviation of $0.2 \times \Delta f$ max is obtained on the deviation meter.

CQM5662 S12 : ± 1.0 kHz

CQM5663 S12 : ± 0.8 kHz

Vary the frequency of the generator and note the deviation changes as referred to the 1000 Hz value.

Requirement :

Within the frequency range 400-2700 Hz the frequency characteristic shall lie within +1 dB/-1.5 dB related to a 6 dB/octave characteristic.

With 6 kHz modulation frequency the deviation shall be attenuated at least 6 dB below the 1 kHz value.

ADJUSTMENT OF TONE EQUIPMENT

Measuring equipment

Tone Test Generator Storno TS-G13
95B0251-00

Check the connections and the tone combination of the TQ5001/TQ5002/TQ5004/TQ5005 and SU/5002; refer to description and diagrams.

Adjustment of frequency deviation

Apply Standard test condition to the transmitter; refer to transmitter test setup.

Establish a shortcircuit between emitter and collector of Q108, on the solder side of the TQ unit, which will produce a continuous tone to the modulator.

Key the transmitter using the tone button.

Adjust R113, TQ5001/TQ5002/TQ5004/TQ5005 for 70% of maximum frequency deviation.

Remove the short circuit.

Connect the G13 Tone Test set to the AF output on the Deviation Meter.

Check that the tone call is properly received when the tone button is depressed.

Checking the Tone Receiver

Apply Standard test condition to the receiver; refer to receiver test setup.

Modulate the signal generator with the G13 Tone Test Set.

Set the G13 to the proper tone combination.

Check that the TQ unit responds to a released tone call.

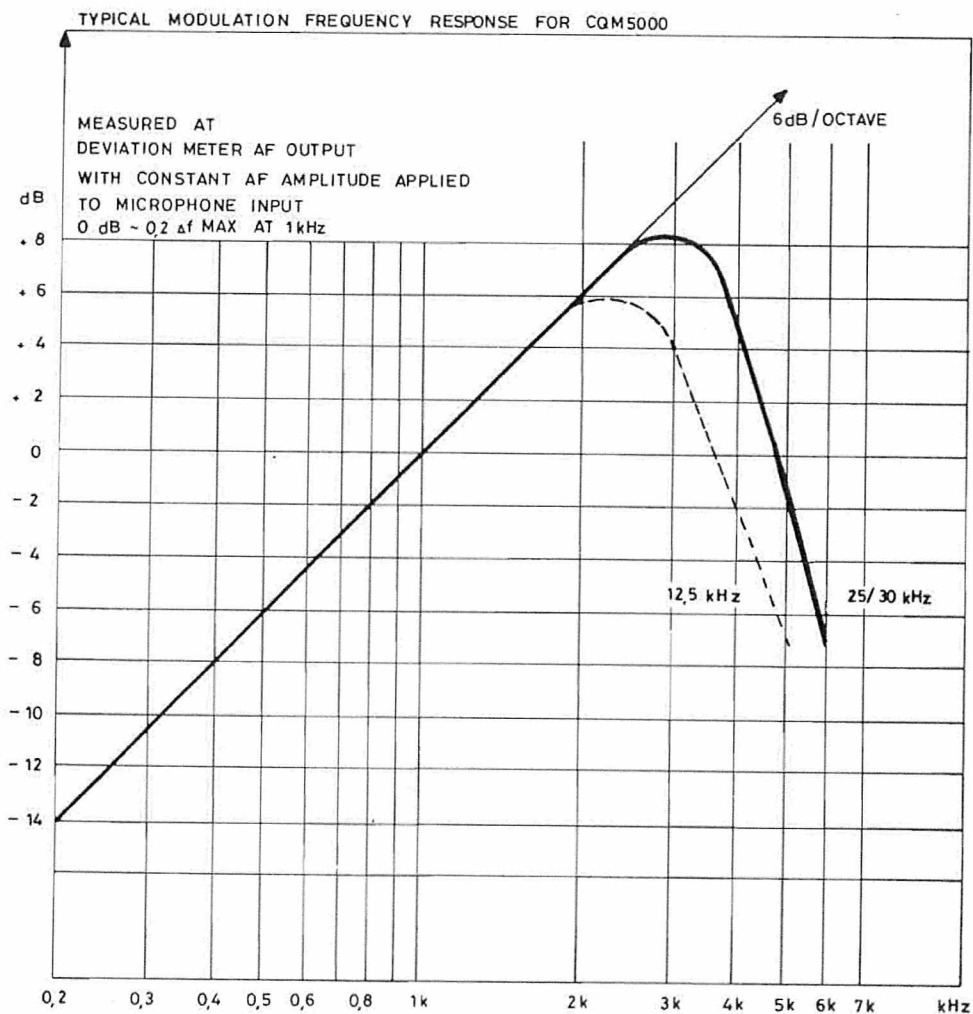

TECHNICAL SPECIFICATIONS

CQM5660 S99

Guaranteed performance specifications unless otherwise noted.

Typical values are given in brackets.

GENERAL

Frequency Range

420 - 470 MHz

Channel Separation

CQM5662: 30/25 kHz

CQM5663: 20 kHz

Maximum Frequency Deviation

CQM5662: ± 5 kHz

CQM5663: ± 4 kHz

Modulation Frequency Range

300 - 3000 Hz

Maximum RF Bandwidth

RX: 3.0 MHz

TX: 5.1 MHz

Antenna Impedance

50 ohm

Maximum Number of Channels

99

Supply Voltage

Minimum: 10.8 V

Nominal: 13.2 V

Maximum: 16.6 V

Negative potential to chassis

Temperature Range

-30°C to $+60^{\circ}\text{C}$

Dimensions

B x D x H: 180 x 190 x 60 mm

Weight

1.8 kg

RECEIVER

Sensitivity

12 dB SINAD (EIA), $\frac{1}{2}$ e.m.f.

0.4 μV (0.3 μV)

Measuring conditions:

$\Delta f, \pm 2/3 \times \Delta f_{\text{max}}$; $f_{\text{mod}} = 1$ kHz

20 dB SINAD (CEPT) e.m.f.

1.0 μV (0.7 μV)

$\Delta F 60\% \times \Delta f_{\text{max}}$; $f_{\text{mod}} = 1$ kHz.

Measured with psophometric filter.

Crystal Frequency Range

420 - 450 MHz: 48.17 - 51.23 MHz

440 - 470 MHz: 45.95 - 49.01 MHz

Receiver VCO Frequency Range

139 - 157 MHz

Crystal Frequency Multiplication

x3

Frequency Stability

Conforms with governments regulations

Modulation Acceptance Bandwidth (EIA) ± 7 kHz (± 7.5 kHz)Adjacent Channel Selectivity

EIA

75 dB (80 dB)

CEPT

75 dB (80 dB)

Spurious Rejection

EIA

85 dB

Intermodulation Attenuation

EIA

70 dB

CEPT

70 dB (78 dB)

Blocking

90 dB/uV (100 dB/uV)

Radiation

Conducted: max. 0.8 nW

Radiated: max. 0.8 nW

AF Load Impedance (Loudspeaker)

4 ohm

AF Power Output

3 W (3.6 W)

AF Distortion

5% (1.5%)

 $\Delta f = \pm 3$ kHz, 1 kHz, 1 W, RF 1 mVFrequency ResponseCQM5662S99, CQM5663S99

+1/-3 dB (+0/-1.5 dB) CEPT

Relative to 1000 Hz, -6 dB/octave

fm: 300 - 3000 Hz

CQM5663S99

+1/1.5 dB (+0/-1 dB) CEPT/FTZ

Relative to 1000 Hz, -6 dB/octave

fm: 400 - 2700 Hz

Hum and Noise

Squelched : 80 dB (better than 85 dB)

Unsquelched : 55 dB (57 dB)

Squelch Recovery Time

250 ms (200 ms)

Squelch Attack Time, EIA

150 ms (110 ms)

Squelch Closing Time, EIA

150 ms (50 ms)

Current Consumption

Squelched: 1000 mA (750 mA)

AF 3 W: 1450 mA (1150 mA)

(13.2 V supply)

TRANSMITTER

RF Power Output

CQM5660-5 W: 5 W

CQM5660-20 W: 20 W

 $R_L = 50$ ohmCrystal Frequency Range

45.95 - 51.23 MHz

Crystal Frequency Multiflication

x3

Transmitter VCO Frequency Range

140 - 156 MHz

Frequency Stability

Conforms with government regulations

Undesired Radiationmax. 0.2 μ WSideband Noise Power, CEPT

less than 70 dB

AF Input Impedance

560 ohm

Modulation Sensitivity90 mV \pm 3 dB(60%, $\Delta f = \pm 3$ kHz, 1 kHz)Modulation Response300 - 3000 Hz (CEPT)

+1/-3.0 dB (+0.5/-2 dB)

relative to 1000 Hz, 6 dB/octave

400 - 2700 Hz

+1/-1.5 dB (+0.5/-1 dB) relative to 1000 Hz,
6 dB/octaveModulation Distortion

fm= 1000 Hz: max. 3%

fm= 300 Hz: max. 5%

CQM5662: $\Delta f = \pm 3$ kHzCQM5663: $\Delta f = \pm 2.4$ kHzFM Hum and Noise

55 dB (57 dB)

CEPT (measured with 750 usec de-emphasis)

Attack Time

50 ms

Current Consumption

5 W: less than 2.5 A (2 A)

20 W: less than 6.2 A (5.5 A)

GENERAL DESCRIPTION

CQM5660 S99

The Stornophone 5000 is a mobile radiotelephone unit with self-contained controls keyboard and display.

A comparison of the various models are presented in the table below.

Although compact in size, it contains a transmitter/receiver, a microcomputer controlled synthesizer and tone equipment, optional 5-tone sequential encoder/decoder or Channel Guard, and up to 99 transmit and receive channels.

Type	CQM5662 S99		CQM5663 S99	
SPEC	5	20	5	20
Frequency Range MHz	420 - 470		420 - 470	
RF Power W	5	20	5	20
Channel Spacing kHz	30/25		20	
Max. Number of Channels	99		99	

ACCESSORIES

Standard accessories include:

Mounting frame

Power cable

Fist microphone with retainer or

Fixed - mount microphone

External loudspeaker

External switches

MN5001 Mounting frame for mobile installations allowing the radio to be fixed in 36 positions. Includes a base plate with locking screw.

MN703 Desk stand for fixed installations.

MN704a Mounting frame for mobile installations and direct attachment to the vehicle.

MC5001 Fist microphone with retractable spiral cable for mobile installation.

HS5001 Retainer for MC5001.

HS5002 Retainer, with switches, for MC5001

MC704 Microphone with chockabsorbing mounting bracket for mobile installation.

MC703 Desk microphone with PTT switch for fixed installations.

MK5001 Installation kit containing connectors, power cable, fuses and fuseholders.

LS701 Loudspeaker enclosed in a plastic housing, complete with cable.

SU701 Transmitter keying switch for mounting on the steering column.

SU702 Transmitter keying switch for mounting on the dashboard.

PS702 Power supply regulator for 24 V car battery installations.

PS5001 Power supply for 220 V AC mains.

MECHANICAL AND ELECTRICAL DESCRIPTION

The internal construction of CQM5000 is on an H-frame chassis with a shelf separating the receiver/transmitter (RF) printed circuit board and the various option printed boards. Front panel controls, display and keyboard are an integral part of the Control Panel.

The chassis is a die cast aluminium frame comprising the left and right sides, the back, and a shelf located midway between the top and bottom. The chassis front is open and looks like an "H" viewed from the front.

Interconnection to the package exterior and to internal options are made via the Frequency Synthesizer Board located on the option side of the H-frame. A test connector is also located on the synthesizer board and is accessible from the rear of the radio.

The moulded plastic front is directly attached to the chassis and has the speaker mounted to it. A separate moulded control panel and aluminum nameplate are attached to the front.

The top and bottom covers slides under the edge of the front and are then secured by screws at the rear.

The tone signalling encoder/decoder board (TQ), the Frequency Synthesizer Board (FB), and the Control Logic (CL) mount in the top section of the chassis.

Thin casted shields with adjustment holes are placed over the RF board and the synthesizer board in order to reduce spurious radiation.

RECEIVER DESCRIPTION

The receiver circuitry is placed on the RF board and can be divided into:

- Receiver front end
- 1st IF section with first and second oscillator
- 455 kHz 2nd IF portion with demodulator.
- Squelch
- Audio Amplifier

(refer to functional block diagram)

FRONT-END

The receiver front-end consists of a dual-resonator input filter, a transistor RF amplifier, Q401, a triple-resonator intermediate filter and a FET mixer, Q402. The drain of the FET

is terminated in the first IF resonant circuit which adapts the output impedance to the crystal filter. The front-end, antenna relay, first mixer and part of the transmitter PA interconnections are designed in micro-stripline techniques on the mainboard.

1st IF

The first IF frequency is 21.4 MHz. The output from the crystal filter is fed to a dual-gate MOSFET amplifier, Q501, the output signal of which is fed to the second mixer, U501, a single balanced, self-oscillating, active mixer. Out of the second mixer comes the 455 kHz IF signal. Two diodes, D501-502, limit the output from the mixer.

455 kHz IF/DEMODULATOR

The selectivity of the 455 kHz IF amplifier is formed by a ceramic filter fed from a 455 kHz amplifier/impedance transforming stage. The final 455 kHz amplification and limiting is performed by an integrated circuit, U502, which also contains the quadrature FM detector and the AF amplifier/output emitter follower for the audio line signal.

value rectifier. A Schmitt Trigger gives the necessary hysteresis and a well-defined output from the following buffer stage, Q605. In the squelched condition and during transmissions this output is +1.5 V and mutes the audio power amplifier. The transmit indicator is part of the muting function.

A push button switch, S601, cancels the squelch function, when depressed, by grounding the base of Q601.

SQUELCH AND AUDIO CIRCUITS

The audio line signal (Vol/Sq - HI) is fed to a selective amplifier stage, where noise (frequencies around 8 kHz) is extracted from the audio signal. Via the squelch potentiometer R607, this signal reaches an expander stage which improves the level discrimination characteristics of the circuit. A passive voltage doubler circuit (D603-D604) with high source impedance performs the action of an average

AUDIO

In sets with Pilot tone option (CG), the audio line signal is fed to the Pilot tone board for filtering and back to the main board. In sets without CG this path is bypassed and the audio line signal is fed directly to the passive deemphasis network R629-C608 followed by the volume control. The volume control potentiometer R630 is mounted directly on the RF board and protrude through the front panel.

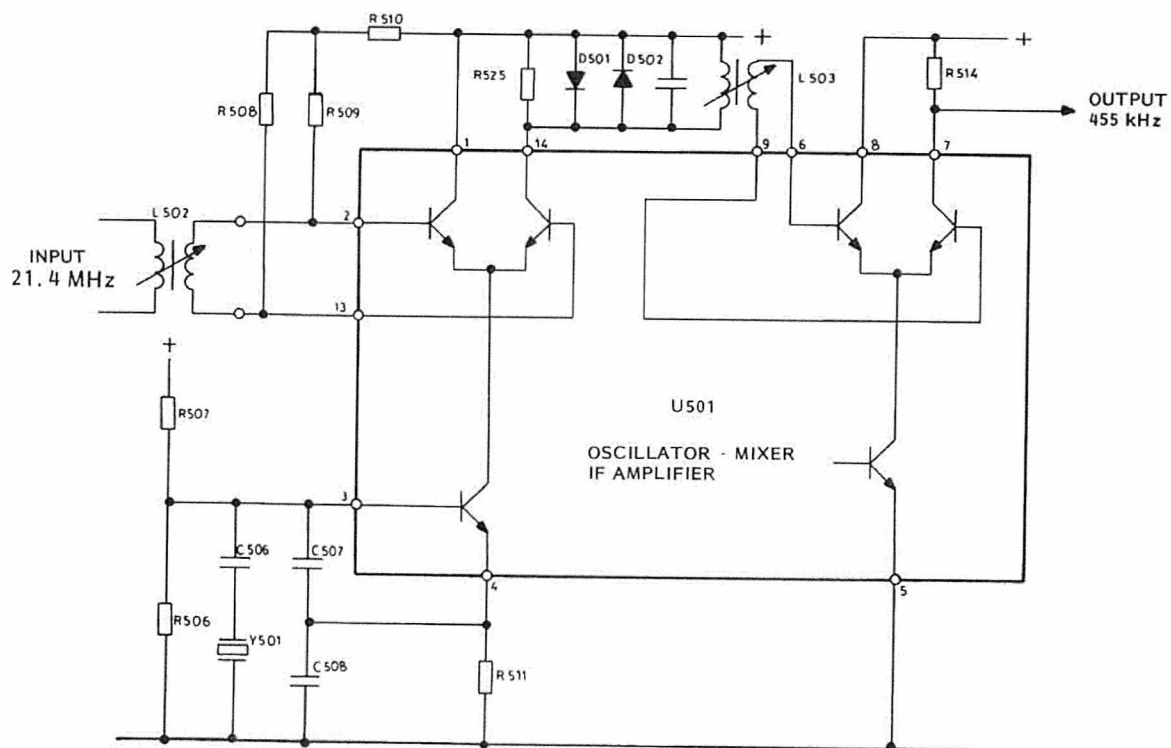

FIG. 1. SECOND OSCILLATOR, IF MIXER, AND IF AMPLIFIER

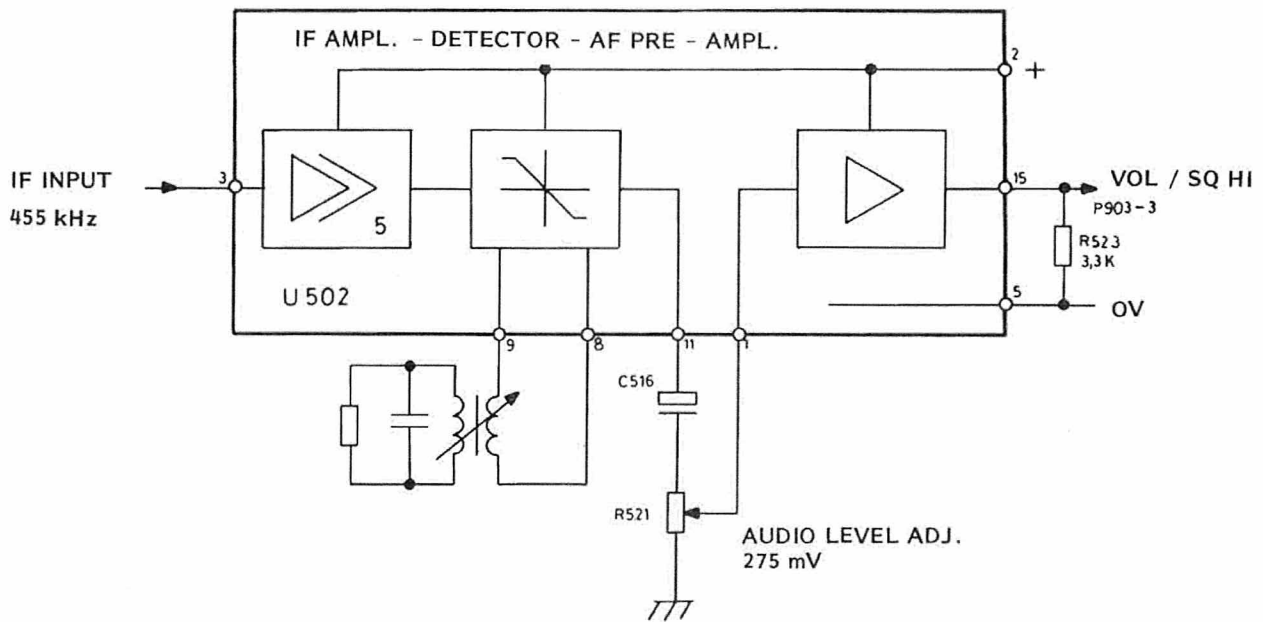

FIG. 2. IF AMPLIFIER , DETECTOR , AND AF PREAMPLIFIER

The audio output amplifier U601 is a monolithic IC package capable of driving the loudspeaker at the desired power level. The output amplifier can be muted with a DC signal from the audio mute gate, which combines different logic signals to decide whether the amplifier should be active or not. These inputs are:

- Regulated TX Voltage
- Squelch cancel
- Squelch signal

In sets equipped with Pilot tone and/or 5-tone sequential option, an RX mute function is routed from the option board to make the extra mute conditions possible. The value of C610 in the feed back loop is chosen as the best compromise between battery ripple rejection and receiver squelch attack time. The pilot lamp in the channel knob is supplied from A+, but controlled by the regulated 8.5 V via transistor Q968.

TRANSMITTER

The transmitter consists of a modulation processor, an exciter, and a power amplifier, all assembled on the RF board along with the receiver.

The exciter contains, an audio processor, all frequency multiplier functions, and includes those stages operating at low enough power levels to avoid heat sinks. The exciter output is at the carrier frequency when applied to the power amplifier. The power amplifier boosts the signal to the proper level, and in-

cludes a low pass filter for suppressing harmonics and a circuitry which permits adjustment of the operating power level. The PA low pass filter connects to the antenna relay via a stripline on the board.

MODULATION PROCESSOR

The signal from the microphone load R901 on the FS board is applied to amplifier U101b. The transmitter audio frequency response is

shaped by the feedback network R104-R103-C104.

The modulation limiting is obtained in the feedback network formed by D101, D102, R105, R106 and R107. The maximum permissible frequency deviation is set by a DEV. BAL. potentiometer on the FS board.

Amplifier U101A is operated as an active low-pass splatter filter feeding the modulating input of the VCO on the Frequency Synthesizer board.

EXCITER

The exciter takes the synthesized signal, filters it to reduce spurious signals and amplifies it. Four amplifier stages (Q201-2-3-4) and four filters (L204-5-8-9) are used in a narrow band design which limits the maximum frequency spread of the transmitter. The exciter has three test points (TP201-2-3) for measurements and alignment.

POWER AMPLIFIER

The PA is constructed on the main board and employs two broadband untuned amplifier stages Q205, Q206. Two amplifier configurations are available providing options of power levels of 10 watts or 25 watts. A power control circuit is included to sense the output RF level and keep it constant with variations in temperature and supply voltage. This circuit also limits the peak power to less than maximum, as specified by the authorities, while still maintaining the output as near maximum as possible. The output power level can be set with a potentiometer, R215, over at least a 3:1 range. The transmitter delivers rated power into a 50-ohm load. A load SWR of 1.4:1 will result in more than 90% of the power being radiated. The transmitter will operate into a load with up to 3:1 SWR.

The power adjustment is achieved by controlling the supply voltage of power amplifier Q205 via transistor Q207. This series transi-

stor is biased by a voltage generated by the feedback network C255, D201, Q201, Q209, Q208.

FREQUENCY SYNTHESIZER AND CONTROL LOGIC

The frequency synthesizer FS5661 provides up to 99 channels and is built on a printed wiring board which mounts in the top section of the radioset.

The frequency of the synthesizer board is set by a binary code from the control logic board CL5001 which is placed over the main section of the synthesizer board.

The Frequency Synthesizer board also carries all interconnections between the tone modules and the RF module, and it has two connectors at the rear for accessories and the power supply cable.

SUPPLY VOLTAGE DISTRIBUTION SYSTEM

The battery voltage (A + BATT) enters the radio via two pins of the rear system connector to the synthesizer board. Both inputs are connected to reverse polarity protection diodes D741, D742. The ground lead comes through the same connector and is connected to chassis ground through a fusible printed wiring path which will open in case of the ground wire being accidentally connected to A +.

One battery input goes directly from the synthesizer board via a feed-through capacitor and a connector P907 to the transmitter PA stages. The other input feeds through P903 - J903 to the RF board for two functions. One branch for the audio amplifier passes through an RC-ripple filter R638 - C618 and one of the ON/OFF switch sections S602. The other section of the ON/OFF switch controls the $V_B +$ to the voltage regulator U602 consisting of a monolithic regulator. The regulator output is fixed at 8.5 V by means of a factory adjusted resistor.

Regulated 8.5 V is switched to either the receiver or the transmitter by the antenna relay. The antenna relay is also supplied by the 8.5 V regulated.

The squelch circuit, the modulation processor, parts of the IF amplifier U502, and the Frequency Synthesizer is supplied directly from the continuous 8.5 V.

The receiver front-end, the 10.7 MHz IF stages and the second oscillator are supplied from 8.5 V RX. The transmitter exciter is supplied from 8.5 V TX.

In sets with 5-tone sequential option or Pilot tone, the PTT (Push to talk) lead runs through the option board to provide for correct tone keying function.

WARNING

The transmitter PA transistors contain Beryllia which is poisonous when absorbed by the human body. Dissection, filing, or grinding of these transistor may be hazardous.

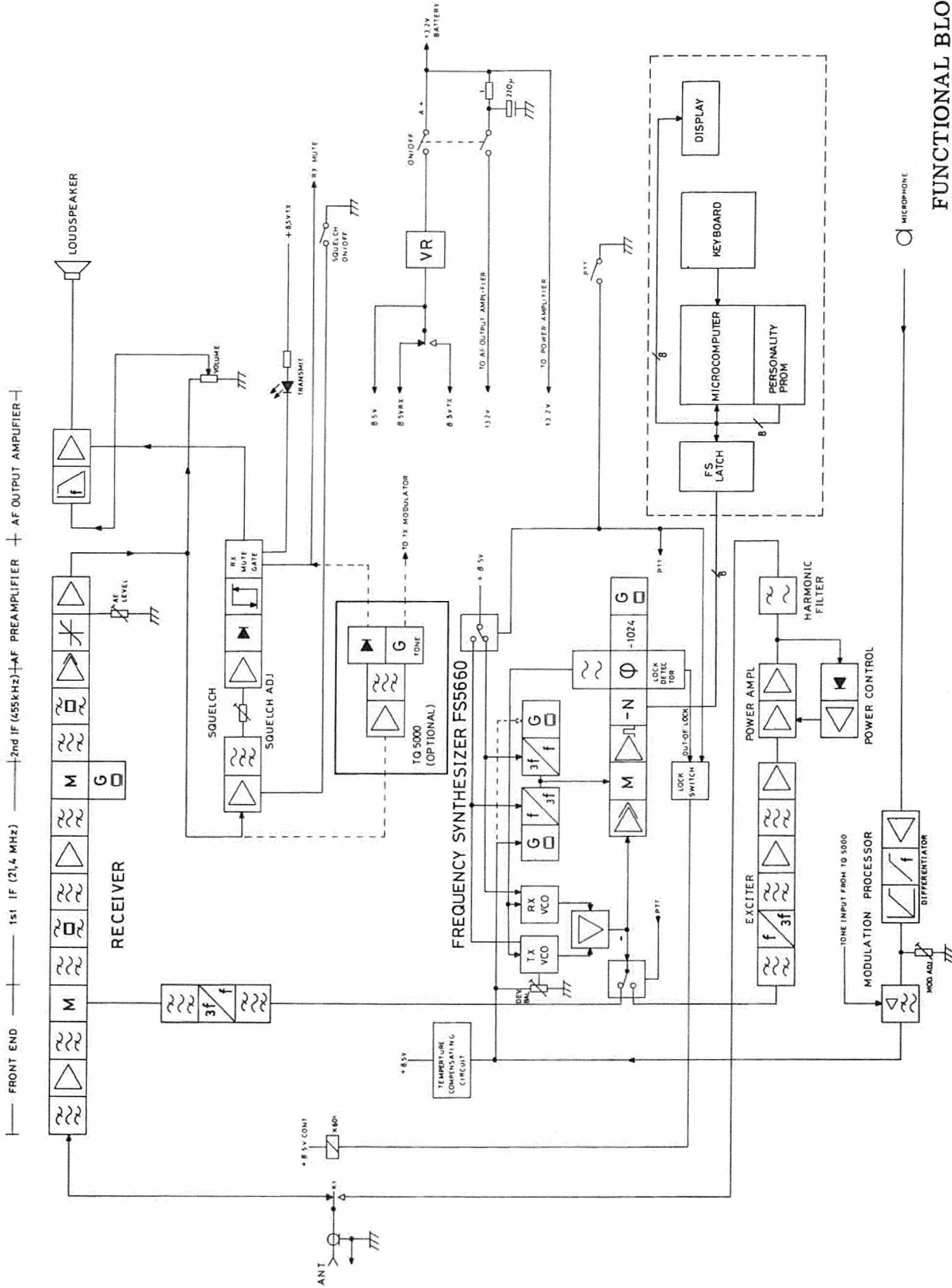

CHANNEL PROGRAMMING INSTRUCTIONS

CQM5660 S99

Programming of the PROM which contains the personality data will normally be part of the factory process, but it may also be field programmed.

The PROM programming unit must be approved by the PROM manufacturer, as for example (DATA I/O SYSTEM 19).

The programmer consists of the following items:

Programmer (DATA I/O SYSTEM 19)

Programming Pak, interchangeable

Socket adaptor

or universal programming pack.

DATA I/O UNIPAK (adaptable for more than 200 types of PROM devices).

To program a PROM the channel frequencies for all allocated channels and the channel spacing must be known.

It is recommended to complete a worksheet when calculating the PROM data.

It is also possible to use a computer to calculate the PROM data and Storno will be able to supply software programs for certain types of computers.

Operating instructions for the Programmer is supplied by the vendor.

WORKSHEET

For each PROM to be programmed a worksheet should be completed to calculate the input data for each channel.

The procedure for completing the worksheet is:

1. Complete list of receiver channel frequencies. (A).
2. Complete list of transmitter channel frequencies. (B).
3. Find highest (H) and lowest (L) receiving frequencies.
4. Find highest (H) and lowest (L) transmitting frequencies.
5. Select receiver mixer crystal frequency (C) from table 1. The highest and lowest receiver frequencies must be within the selected band.
6. Select transmitter mixer crystal frequency (D) from table 2. The highest and lowest transmitter frequencies must be within the selected band.
7. Note channel spacing and Reference frequency (F). See worksheet.
8. Use receiver formula to calculate " V_{DEC} " (divisor) for all receiver channels.
9. Use transmitter formula to calculate " V_{DEC} " (divisor) for all transmitter channels.
10. Check " V_{DEC} " for all channels to be between 256 and 511.
11. Use receiver crystal frequency and V_{DEC} to check for selfquieting frequencies, table 3.
12. In case of selfquieting select appropriate alternative and possibly recalculate "V".
13. Convert all " V_{DEC} " numbers to hexadecimal code. Refer to tabel 4.
14. Assign the hexadecimal codes to the corresponding channels and the PROM adresses.

After completing the worksheet enter correct Prom addresses and corresponding data (V_{HEX}) on the Programmer (DATA I/O), refer to Programmer Operating Instructions.

RECOMMENDED CRYSTAL FREQUENCIES

CQM5660 S99

CQM5662 FREQUENCY RANGE	CQM5663 FREQUENCY RANGE	RX CRYSTAL
418.6 - 424.9755	417.32 - 422.42	48.177777
421.1 - 427.4755	419.82 - 424.92	48.455555
423.6 - 429.9755	422.32 - 427.42	48.733333
426.1 - 432.4755	424.82 - 429.92	49.011111
428.6 - 434.9755	427.32 - 432.42	49.288888
431.1 - 437.4755	429.82 - 434.92	49.566666
433.6 - 439.9755	432.32 - 437.42	49.844444
436.1 - 442.4755	434.82 - 439.92	50.122222
438.6 - 444.9755	437.32 - 442.42	50.399999
441.1 - 447.4755	439.82 - 444.92	50.677777
443.6 - 449.9755	442.32 - 447.42	50.955555
446.1 - 452.4755	444.82 - 449.92	51.233333
441.4 - 447.7755	440.12 - 445.22	45.955555
443.9 - 450.2755	442.62 - 447.72	46.233333
446.4 - 452.7755	445.12 - 450.22	46.511111
448.9 - 455.2755	447.62 - 452.72	46.788888
451.4 - 457.7775	450.12 - 455.22	47.066666
453.9 - 460.2775	452.62 - 457.72	47.344444
456.4 - 462.7755	455.12 - 460.22	47.622222
458.9 - 465.2755	457.62 - 462.72	47.899999
461.4 - 467.7755	460.12 - 465.22	48.177777
463.9 - 470.2755	462.62 - 467.72	48.455555
466.4 - 472.7755	465.12 - 470.22	48.733333
468.9 - 475.2755	467.62 - 472.72	49.011111

TABLE 1. RECEIVER MIXER CRYSTAL FREQUENCY

RECOMMENDED CRYSTAL FREQUENCIES

CQM5660 S99

CQM5662 FREQUENCY RANGE	CQM5663 FREQUENCY RANGE	TX CRYSTAL
420.0 - 426.375	418.72 - 423.82	45.955555
422.5 - 428.875	421.22 - 426.32	46.233333
425.0 - 431.375	423.72 - 428.82	46.511111
427.5 - 433.875	426.22 - 431.32	46.788888
430.0 - 436.375	428.72 - 433.82	47.066666
432.5 - 438.875	431.22 - 436.32	47.344444
435.0 - 441.375	433.72 - 438.82	47.622222
437.5 - 443.875	436.22 - 441.32	47.899999
440.0 - 446.375	438.72 - 443.82	48.177777
442.5 - 448.875	441.22 - 446.32	48.455555
445.0 - 451.375	443.72 - 448.82	48.733333
447.5 - 453.875	446.22 - 451.32	49.011111
450.0 - 456.375	448.72 - 453.82	49.288888
452.5 - 458.875	451.22 - 456.32	49.566666
455.0 - 461.375	453.72 - 458.82	49.844444
457.5 - 463.875	456.22 - 461.32	50.122222
460.0 - 466.375	458.72 - 463.82	50.399999
462.5 - 468.875	461.22 - 466.32	50.677777
465.0 - 471.375	463.72 - 468.82	50.955555
467.5 - 473.875	466.22 - 471.32	51.233333

TABLE 2. TRANSMITTER MIXER CRYSTAL FREQUENCY

SELFQUIETING FREQUENCIES

CQM5662 S99

RECEIVER CRYSTAL FREQUENCY. MHz	V DEC	USE ALTERNATIVE ⁺
All crystal frequencies	428	1
48.177	265	2
48.177	274	4
48.733	416	4
48.733	459	4
49.844	466	2
50.122	366	2
50.399	266	2
50.399	397	4
47.622	465	2
47.899	328	2

⁺refer to worksheet

TABLE 3A. SELFQUIETING FREQUENCIES

SELFQUIETING FREQUENCIES

CQM5663 S99

RECEIVER CRYSTAL FREQUENCY. MHz	V DEC	USE ALTERNATIVE ⁺
48.177	278	4
48.177	286	2
48.177	331	4
49.566	290	4
50.122	458	4
50.122	503	4
50.399	333	2
50.399	378	2
45.955	284	4
46.511	374	2
46.788	375	4
47.899	399	4
47.899	411	4
47.899	456	2
48.177	274	4
48.177	286	4
48.177	331	4
48.177	420	2
48.733	390	4
48.733	394	2
49.011	265	4

⁺ refer to worksheet

TABLE 3B. SELFQUIETING FREQUENCIES

HEX CODE CONVERSION TABLE

		Least Significant Digit (LSD) of Hex Code															
		0	1	2	3	4	5	6	7	8	9	A	B	C	D	E	F
Most Significant Digit of Hex Code.	0	256	257	258	259	260	261	262	263	264	265	266	267	268	269	270	271
	1	272	273	274	275	276	277	278	279	280	281	282	283	284	285	286	287
	2	288	289	290	291	292	293	294	295	296	297	298	299	300	301	302	303
	3	304	305	306	307	308	309	310	311	312	313	314	315	316	317	318	319
	4	320	321	322	323	324	325	326	327	328	329	330	331	332	333	334	335
	5	336	337	338	339	340	341	342	343	344	345	346	347	348	349	350	351
	6	352	353	354	355	356	357	358	359	360	361	362	363	364	365	366	367
	7	368	369	370	371	372	373	374	375	376	377	378	379	380	381	382	383
	8	384	385	386	387	388	389	390	391	392	393	394	395	396	397	398	399
	9	400	401	402	403	404	405	406	407	408	409	410	411	412	413	414	415
	A	416	417	418	419	420	421	422	423	424	425	426	427	428	429	430	431
	B	432	433	434	435	436	437	438	439	440	441	442	443	444	445	446	447
	C	448	449	450	451	452	453	454	455	456	457	458	459	460	461	462	463
	D	464	465	466	467	468	469	470	471	472	473	474	475	476	477	478	479
	E	480	481	482	483	484	485	486	487	488	489	490	491	492	493	494	495
	F	496	497	498	499	500	501	502	503	504	505	506	507	508	509	510	511

"V_{DEC}" Numbers.



Example "V_{DEC}" = 345 equals to hex code 59.
 "V_{DEC}" = 469 equals to hex code D5.

Table 4.
 "V" Number to hex code conversion table.

PROGRAMMING WORKSHEET

FOR CQM5660 S99

Customer:

RECEIVER						TRANSMITTER				
CHAN- NEL	A FREQUENCY MHz	L H	V DEC	V HEX	PROM ADDRESS (HEX)	B FREQUENCY MHz	L H	V DEC	V HEX	PROM ADDRESS (HEX)
1										
2										
3										
4										
5										
6										
7										
8										
9										
10										
11										
12										
RECEIVER MIXER CRYSTAL FREQ. (Y702). C=_____						TRANSMITTER MIXER CRYSTAL FREQ. (Y701) D=_____				
420 - 450 MHz: $V_{DEC} = \frac{(A + 21.4) - (C \times 9)}{3 \times F}$						FORMULA: $V_{DEC} = \frac{B - (D \times 9)}{3 \times F}$				
440 - 470 MHz: $V_{DEC} = \frac{(A - 21.4) - (C \times 9)}{3 \times F}$										

CHANNEL SPACING:	REFERENCE CRYSTAL (Y703):	REFERENCE FREQUENCY:
20 kHz	6.8266 MHz	F= 0.006666
25 kHz	8.5333 MHz	F= 0.008333

LIST OF REFERENCE CRYSTALS (Y703)			ALTERNATIVE SOLUTIONS IF THE RECEIVER IS SELFQUIETING:		
MODE	FREQUENCY, MHz	PART No.	1.	2.	3.
Standard 5662	8.5333333	19J706361P3	SELECT ANOTHER RX MIXER CRYSTAL FREQUENCY	SELECT HIGH INJECTION FREQUENCY FOR 2nd OSCILLATOR	Y501= 21.85500 MHz INSTEAD OF 20.945000 MHz
Standard 5663	6.8266666	19J706361P4	USE SLIGHTLY OFFSET REFERENCE CRYSTAL	WEAK QUIETING; NO ALTERNATIVE REQUIRED	

ADJUSTMENT PROCEDURE

CQM5660 S99

This adjustment procedure applies to the following radiotelephone types:

CQM5662 : 30/25 kHz Channel spacing

CQM5663 : 20 kHz Channel spacing

Before making adjustments to the radiotelephone transmitter/receiver, read the type label and note the channel frequencies.

Check all straps according to the notes on the diagrams. Also check the selective calling tone equipment, if any, against the coding instructions; refer to description of tone equipment.

All screens must be in place and properly secured during the adjustments.

MEASURING INSTRUMENTS

The following list contains instruments necessary for adjusting the radiotelephone and checking its performance characteristics:

DC Voltmeter	$R_{in} \geq 1$ Mohm
AC Voltmeter	$Z_{in} > 1$ Mohm//50 pF
Multimeter	$R_i \geq 20$ Kohm/Volt
Distortion meter	e.g. Storno E11c
RF Watt meter	25 W/50 ohm/420-470 MHz
Deviation meter	420-470 MHz
RF generator	$Z_{out} = 50$ ohm; 420-470 MHz
21.4 MHz signal generator	e.g. Storno TS-G21B

Frequency counter with attenuator	$Z_{in} = 50$ ohm; sensitivity 100 mV at 470 MHz
RF diode probe	Storno 95.0089-00
RF coaxial probe	Storno 95.0179-00
DC power supply	10.8 V - 16.6 V; 6A
Oscilloscope	0 - 5 MHz min.

MISCELLANEOUS

4 ohm/3 W resistor	3 x Storno code 82.5026-00
22 uF/40 V electrolytic capacitor	Storno code 73.5107-00
Connector, 11-pin house	Storno code 41.5543-00
Connector, 8-pin house	Storno code 41.5542-00
Pins for connectors	Storno code 41.5551-00
Trimming tools	

The following tables show the frequency ranges of the CQM5660 S12 radiotelephone signals:

SIGNAL	FREQUENCY MHz
TX VCO	140 - 156
TX crystal	45 - 50
TX crystal multiplication	x3
RX VCO	139 - 157
RX crystal	47 - 50 (420 - 450)
RX crystal multiplication	45 - 48 (440 - 470)
	x3

Table 1.

Channel spacing kHz	Reference Crystal MHz	Min. Divider input frequency MHz	Max. Divider input frequency MHz	Reference frequency kHz
20	6.8266	1.7066	3.4066	6.666
30 or 25 ¹⁾	8.5333	2.1333	4.2583	8.333

Table 2

¹⁾ Two steps per channel

RECEIVER TEST SET-UP
CQM5660 S99

D402.935/2

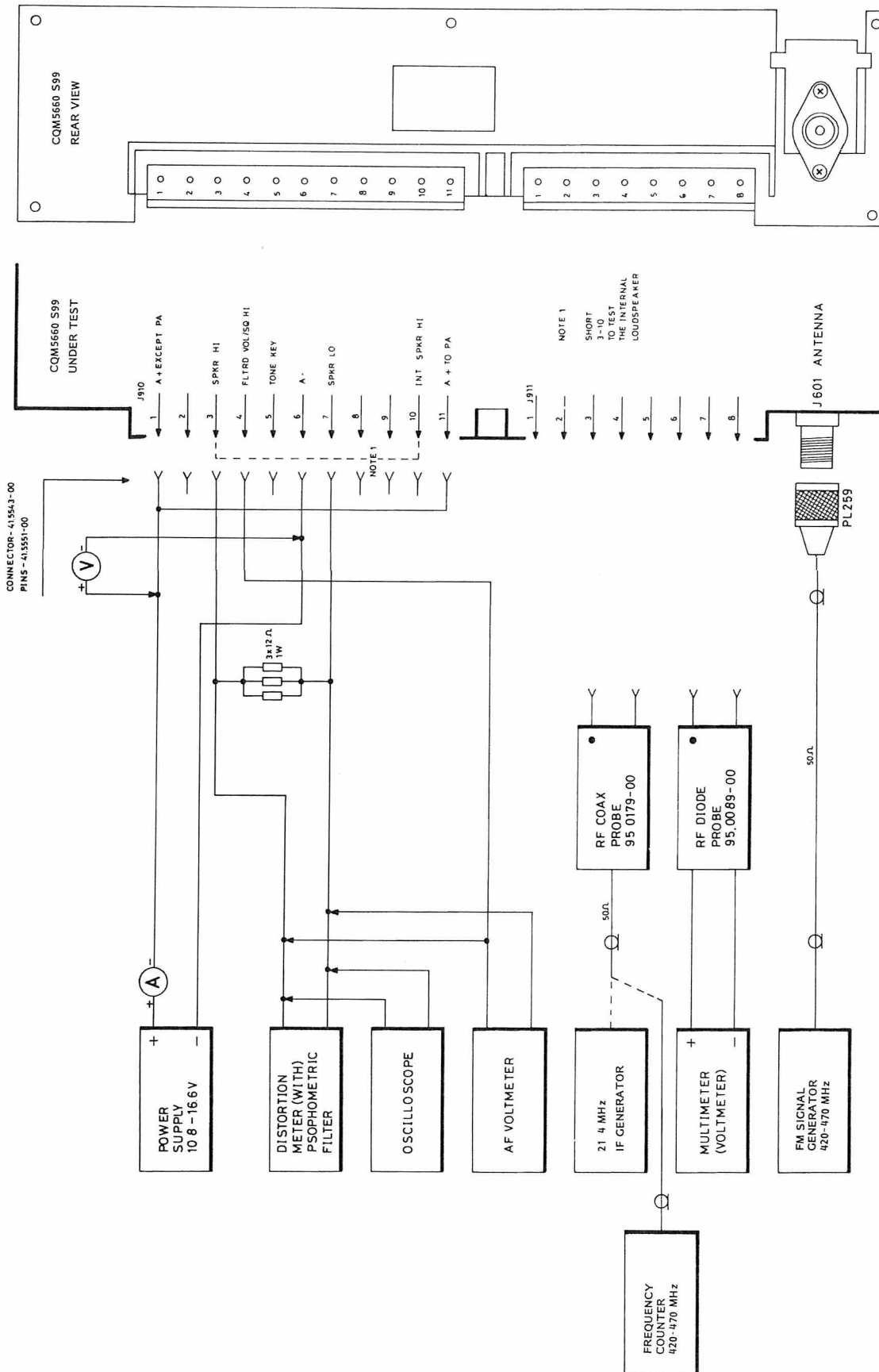

RECEIVER ADJUSTMENT

CHECKING 8.5 V REGULATED SUPPLY

Turn the power supply ON and set the voltage to 13.2 V. Set the power supply current limiter to 1 A.

Turn the radiotelephone ON by depressing the ON/OFF button. Note the light in the Channel selector, if any, is on.

Depress the Squelch button.

Set the volume control to minimum.

Connect the DC voltmeter to J901 pin 3 and read the Voltage.

Requirement: $8.5 \text{ V} \pm 0.15 \text{ V}$

If the requirement is not fulfilled check resistor R636 against the colour code of U602.

U602 colour code	R636 Value
Brown	omit
Red	270
Orange	100
Yellow	47
Green	22
Blue	6.8

Adjust the power supply voltage to 16.6 V and read the 8.5 V regulated. Compare the change in the 8.5 Volt regulated to the value obtained at 13.2 V.

Requirement: $\leq 50 \text{ mV}$

Repeat the procedure with the power supply adjusted for 10.8 V

FREQUENCY SYNTHESIZER ALIGNMENT

Check the PROM U801, the TX mixer crystal, the RX mixer crystal, and the reference crystal and verify the frequencies and PROM codes.

Mixer crystal output

Connect RF diode probe 95.0089-00 with multimeter to test point TP701. (1 V range).

Adjust L711 for maximum deflection on the multimeter.

Adjust L707 for maximum deflection on the multimeter.

Requirement: $45 \text{ mV} \pm 15 \text{ mV}$

(corresponding to -10 dBm to -4 dBm).

Note: Be careful not to resonate L707 to the false harmonics. If in doubt consult table 1 or check the crystal oscillator output with a spectrum analyzer.

Receiver VCO

Connect the multimeter, 10 V range, to test point TP706. The synthesizer's lock signal is accessible at TP706. +8 V DC with very narrow pulses (0.1 μ sec) indicates normal locked condition. Unlocked condition is indicated by a variable duty signal or logic "Low". Select the channel whose frequency is closest to the center frequency.

Await locked condition, constant voltage.

Adjust C745 for 8 Volts on the multimeter.

Connect the multimeter to test point TP703.

Adjust C745 for a voltage corresponding to the variable divider ratio (V) as indicated by the graph fig. 3.

Requirement: The voltage shall be in the range 1.5 V to 6.5 V and not deviate from the graph by more than 20%.

Mixer Crystal Frequency

Connect coax probe 95.0179-00 to test point TP701.

Connect the frequency counter to the probe and read the frequency.

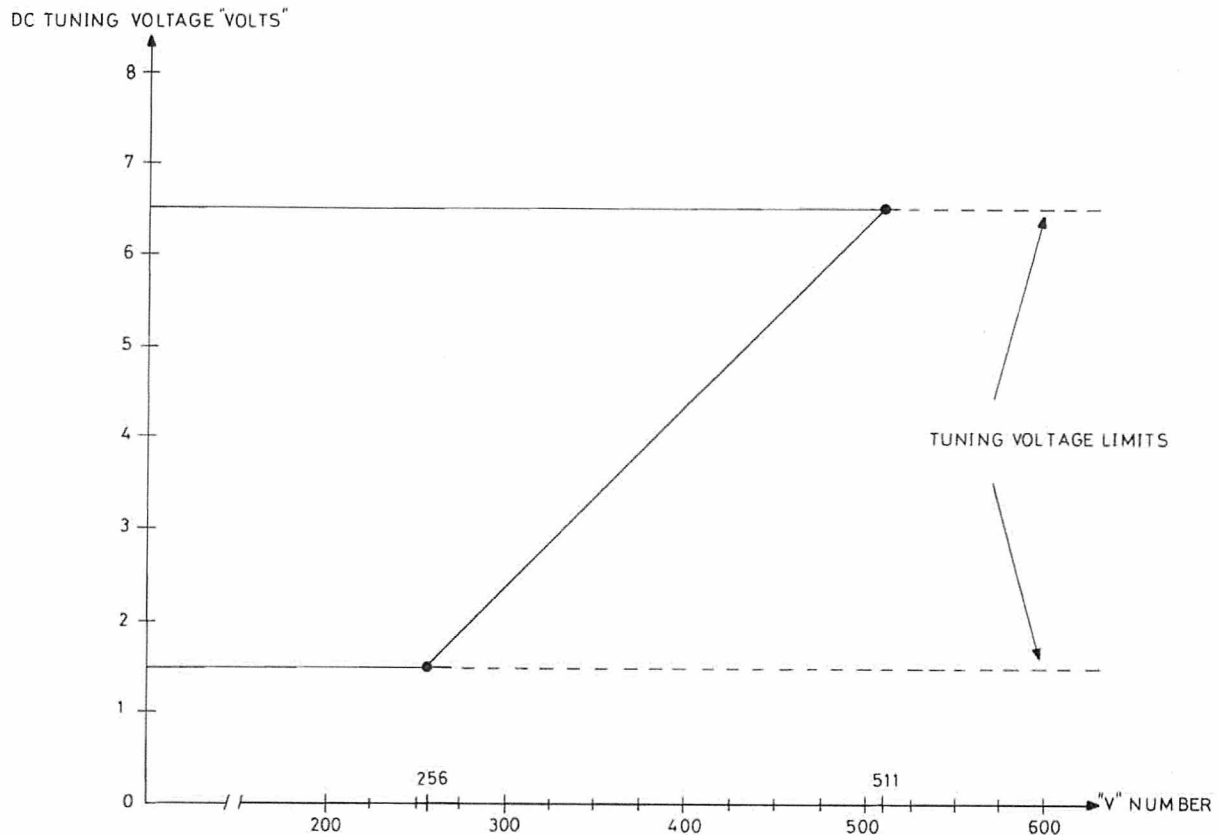

Fig. 1. Tuning voltage vs. V. number.

$f = f_x \times 3$ (f_x = crystal frequency)
 Adjust L711 to the calculated frequency.
 Requirement: $f \pm 0.3$ ppm at 25°C .
 ppm = parts per million = 10^{-6}

Injection Frequency

Connect coax probe 95.0179-00 to test point TP401.
 Connect the frequency counter to the probe.
 Calculate the injection frequency for all channels.

$$f_{inj} = f_{ant} - 21.4 \text{ (MHz)}$$

Select, one by one, the channels and read the injection frequency.

Requirement: $F_{inj} \pm 0.2$ ppm

IF AMPLIFIERS

Connect a 21.4 MHz signal generator to TP401 via coax probe 95.0179-00.
 Connect RF diode probe 95.0089-00 with multimeter to test point TP501. (50 μA range).

During adjustment the RF generator output must be kept low enough to prevent limiting in the IF stages, i.e. a maximum reading of 50 μA on the multimeter.

Adjust coils L503, L502, L501, and L406, in that order, for maximum deflection on the multimeter.

FRONT-END

Connect the RF probe 95.0089-00 and the multimeter to test point TP501. (50 μA range).
 Connect an unmodulated RF generator to the antenna connector, J601.
 Set the generator frequency to the receiver frequency.

Adjust the generator output to produce a deflection on the multimeter, i.e. a maximum reading of 50 μA on the multimeter.

Adjust L401 and L402 for maximum deflection.
 Detune L406: Adjust L405 and L407 for maximum deflection on the multimeter.

Adjust L406 for maximum deflection.
 Readjust L401 and L402 for maximum deflection.
 Remove the RF diode probe.

Standard Test condition:

Connect the RF generator to antenna connector and adjust the output to 1 mV e. m. f.
 Modulate the RF generator with 1000 Hz to 60% of Δf max.

CQM5662 S12/S99 ± 3 kHz
 CQM5663 S12/S99 ± 2.4 kHz

Connect a 4 ohm/3 W resistor load to connector J910/3-7 (SPKR HI-SPKR LO).
 Connect an AF voltmeter to J910/4-7 (FLTD VOL SPKR LO).

IF DEMODULATOR

Turn R521 halfway up.
 Adjust L504 for maximum reading on the AF voltmeter.

Connect a distortion meter and AF voltmeter across the 4 ohm resistor. (if Storno E11c distortion meter is used switch the function to AF voltmeter).

Adjust the volume control for approx. 2 V across the load.

Adjust L501 and L406 for minimum distortion. The demodulated signal may be monitored on an oscilloscope connected in parallel with the distortion meter.

Connect the AF voltmeter and distortion meter to J910/4-7 (FLTD VOL - SPKR LO).

Adjust R521 for a reading of 275 mV on the AF voltmeter.

Requirement: 275 mV ± 5 mV.

Read the distortion.

Typical Total Harmonic Distortion (THD) will be less than 5%.

RECEIVER SENSITIVITY

EIA or CEPT method may be used.

Method of measurement CEPT

The purpose of the measurement is to define the ratio of one condition to another. The first condition is the one where a modulated RF-signal drives the receiver into full limiting. The audio output is measured with the distortion meter (in the CAL position) and, disregarding the amplitude of the audio, this is adjusted to read 100% on the meter scale; this is our reference condition consisting of signal +noise +distortion, where 'signal' is the modulation of the RF, 'noise' is the lowest possible amount achieved from that particular receiver, when receiving a strong carrier, and 'distortion' is the modulation being slightly distorted in passing through the receiver.

The second condition is the one where the signal (modulation) is removed with a notch filter and the RF-signal is lowered in amplitude until the remaining noise and distortion increases to 20 dB below the first condition, as read on the distortion meter scale. This corresponds to a reading of 10%, 10 being 20 dB below 100, which was our reference condition.

In practice our first condition is achieved by feeding a minimum of 1000 μ V of RF-signal modulated with 1000 Hz at 60% Δf max. to the receiver.

The audio output (which must be at least 100% of the receiver's audio rating) is measured through the psophometric filter, with the distortion meter in position CAL and adjusted with potentiometer ADJ. FSD. to a reading of 100.

The notch filter is then inserted in series with the audio by pressing one of the buttons marked in %. The meter needle immediately drops to indicate a low value, this being the receiver's inherent audio distortion.

By backing off the attenuator of the RF generator, thereby lowering the RF input to the receiver, the noise will eventually increase; the attenuator is now adjusted for a 10% reading on the distortion meter scale.

At this stage it must be ensured that the increased noise and the signal (with the notch filter switched out while checking) still equals 100 on the meter scale.

The RF-generator's calibrated attenuator now shows the value of RF-signal required to achieve a 20 dB ratio between signal + noise + distortion and noise + distortion, i. e. 20 dB SINAD sensitivity.

EIA Method

EIA (Electronic Industries Association)

Standard, definition:

The SINAD sensitivity of a receiver is the minimum input signal that will provide at least 50% of the receiver's rated audio power with 12 dB signal + noise + distortion to noise + distortion.

The EIA method differs from CEPT by omitting the psophometric filter, adjusting the RF generator for $2/3 \times \Delta f_{max}$, and measure the distortion at 50% of the receiver's rated AF power. The SINAD sensitivity is measured as a 12 dB ratio between signal + noise + distortion and noise + distortion, which corresponds to a reading of 25% noise + distortion.

ADJUSTING THE SENSITIVITY

Lower the RF generator output to obtain 20 dB SINAD (10% THD as measured with the

distortion meter). Readjust L402 for the best SINAD value, e. i. lowest generator output for 10% THD.

MEASURING 20 dB SINAD (CEPT)

Adjust the volume control for 2.45 V (1.5 W/4 ohm) as measured with an AF voltmeter across the load.

Adjust the RF generator output to obtain 20 dB SINAD condition.

Read the 20 dB SINAD sensitivity (e. m. f.)

Requirement: $\leq 1.0 \mu V$.

The sensitivity should be measured on all channels, if more than one.

MEASURING 12 dB SINAD (EIA)

Adjust the volume control for 2.45 V as measured with an AF voltmeter across the load.

Adjust the RF generator to obtain 12 dB SINAD condition.

Read the 12 dB SINAD sensitivity.

Requirement: $\leq 0.4 \mu V$ ($\frac{1}{2}$ e. m. f.)

The sensitivity should be measured on all channels, if more than one.

AUDIO FREQUENCY RESPONSE

Set the signal generator to Standard Test Condition.

Adjust the volume control for 0.82 V across the load. (4 ohm across (SPKR HI - LO)).

At 13.2 V supply, $\Delta F = 60\% \Delta F_{max}$ and 1000 Hz measure the output voltage according to the following table:

	Frequency	Level	Tol.
CQM5662 S12/S99	300 Hz	+9 dB	+1 dB/-3 dB
	1000 Hz	0 dB	
	3000 Hz	-9.5 dB	+1 dB/-3 dB
CQM5663 S12/S99	300 Hz	+10.5 dB	+1.5 dB/-3 dB
	400 Hz	+8 dB	+1.5 dB/-1.5 dB
	1000 Hz	0 dB	
	2700 Hz	-8.6 dB	+1.5 dB/-1.5 dB
	3000 Hz	-9.5 dB	+1.5 dB/-3 dB
	6000 Hz	<-20 dB	

SELF QUIETING CHECK

Internal oscillators, dividers and the harmonic frequencies hereof, may cause self quieting of the receiver if a mixer product falls in the RF or IF pass band.

For proper operation of the squelch all channels must be checked for the self quieting phenomenon.

Connect the RF generator to the antenna connector. Reduce the RF output to 0.

Set the frequency outside the 420 - 470 MHz band.

Alternatively, an attenuator (50 ohm) may be connected to the antenna connector.

Connect an AF voltmeter across the 4 ohm speaker load.

Adjust the volume control for 774 mV (0 dBm) as read on the AF voltmeter.

Select, in turn, all allocated channels.

The reading on the AF voltmeter shall not on any selected channel decline more than 6 dB.

Requirement: Quieting ≤ 6 dB.

AF POWER OUTPUT

Adjust the RF signal generator to Standard Test Condition.

Set the supply voltage to 13.2 V.

Adjust the volume control for 3 W output (3.46 V across the 4 ohm load).

Measure the distortion (THD).

Requirement: THD $\leq 5\%$.

SQUELCH

Release the squelch cancel button.

Adjust potentiometer R607 squelch adj. to open the receiver for an RF input signal corresponding to 8-10 dB SINAD.

The final squelch adjustment must not be set on a channel that has shown a minor degree of selfquieting.

CURRENT CONSUMPTION

Measure the current consumption at 13.2 V.

Requirements

CONDITION	CURRENT CONSUMPTION	
	S12	S99
Standby	≤ 350 mA	≤ 1000 mA
Receive ~ 2.83 V r. m. s. across 4 ohm.	2 W AF/ ≤ 750 mA	3 W AF/ ≤ 1450 mA

For sets with selective calling facilities add current consumption of the tone unit to the figures above.

TRANSMITTER ADJUSTMENT

Adjust the power supply voltage to 13.2 V and set current limiter as follows:

20 W transmitter:	7 A
5 W transmitter:	4 A

Refer to Receiver Alignment for measuring 8.5 V regulated supply.

Preset all transmitter tuning slugs, L151,

L153, L201, L202, L204, and L205 to be flush with the coil form top.

Connect a multimeter (2.5 volt range) to test point TP201.

Turn the power control potentiometer, R221, to minimum, anticlockwise (CCW).

Connect a Wattmeter, (25 W) to the antenna connector, J601.

FREQUENCY SYNTHESIZER ALIGNMENT

Check the PROM U801, the TX mixer crystal, the RX mixer crystal, and the reference crystal and verify the frequencies and the prom codes.

Mixer crystal output

Connect RF probe 95.0089-00 with multimeter to test point TP701 (1 V range).

Key the transmitter.

Adjust L701 for maximum deflection on the multimeter.

Adjust L704 for maximum deflection on the multimeter.

Requirement:

40 mV \pm 15 mV

(corresponding to -10 dBm to -4 dBm)

Note: Be careful not to resonate L704 to the false harmonics. If in doubt consult table 1 or check the crystal oscillator output with a spectrum analyzer.

Transmitter VCO

Connect the multimeter, 10 V range, to test point TP706.

The synthesizer's lock signal is accessible at TP706 and +8 V DC with very narrow pulses (0.1 μ sec.) indicate normal locked condition. Unlocked condition is indicated by a variable duty signal or logic "LOW".

Select the channel whose frequency is closest to the center frequency. Key the transmitter.

Await locked condition.

Adjust C737 for 8 Volts on the multimeter.

Connect the voltmeter to test point TP703.

Adjust C737 for a voltage corresponding to the variable divider ratio (V) as indicated by the graph fig. 1.

Requirement: The voltage shall be in the range 1.5 V to 6.5 V and not deviate from the graph by more than 20%.

Mixer Crystal Frequency

Connect coax probe 95.0179-00 to test point TP702.

Connect the frequency counter to the probe, key the transmitter and read the frequency.

$f = f_x \times 3$ (f_x = crystal frequency).

Adjust L701 to the calculated frequency.

Requirement: $f \pm 0.3$ ppm at 25°C.

ppm = parts per million = 10^{-6} .

Synthesizer Output Level

Connect a multimeter, 2.5 V range, to test point TP201. Key the transmitter.

Adjust L153 for maximum deflection on the multimeter, typical more than 0.75 V.

EXCITER

Connect a multimeter (1.0 V range) to test point TP201.

Adjust L203 for minimum deflection. The dip is small.

Connect the multimeter, (1 V range) to test point TP202.

Adjust L204 for maximum deflection on the multimeter, typical 0.7 V.

Repeat the adjustments of L203, L153, and L151 (L921-L926) until no further improvements is obtainable.

Adjust C213 for minimum reading. The dip is small.

Connect the multimeter, 1 volt range, to test point TP203.

Adjust C215 for maximum reading on the multimeter, typical 0.5 V.

Repeat the adjustment of C213 and L204 until no further improvement is obtainable.

Adjust C221 minimum deflection. The dip is small and careful tuning is required.

Connect the multimeter, 10 volt range, to the RF probe.

Connect RF diode probe 95.0089-00 to TP204. Adjust C221 and C223 for maximum deflection (typical 4.0 V).

Adjust the PA power control, R215, for rated transmitter power, 5 W or 20 W.

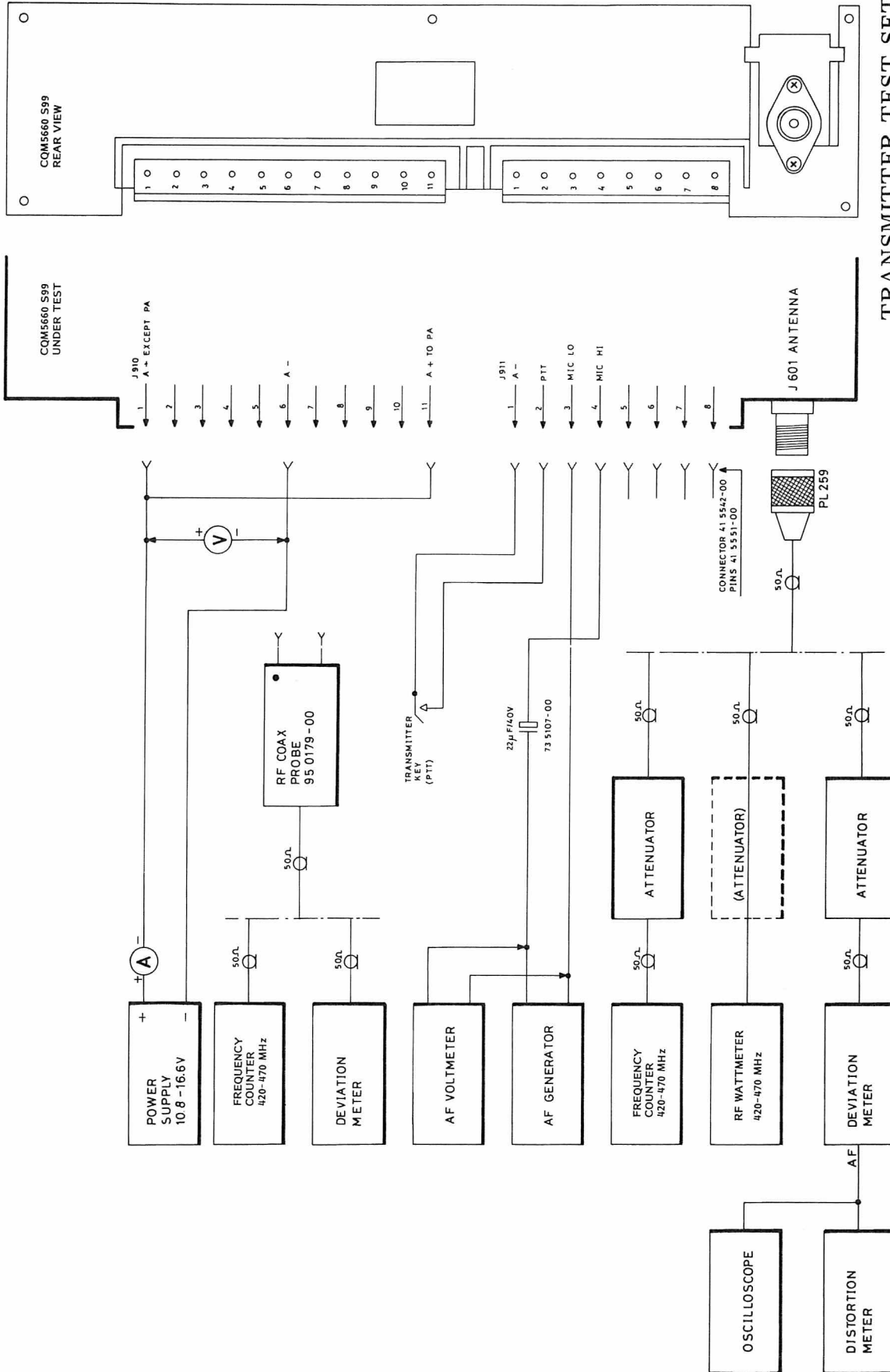

TRANSMITTER TEST SET-UP
CQM5660 S99

D402.937/2

EXCITER, FINE ADJUSTMENT

Connect the multimeter to test point TP201.
 Readjust L153 for maximum reading.
 Connect the multimeter to test point TP202.
 Peak L203 and L204 for maximum reading.
 Connect the multimeter to test point TP203.
 Connect C213 and C215 for maximum reading.
 Connect the 95.0089-00 RF probe and multi-
 meter to TP204.
 Adjust C221 and C223 for maximum reading.

TYPICAL TEST POINT READINGS

TP201: 0.2 V
 TP202: 0.7 V
 TP203: 0.5 V
 TP204: 4.0 V

TRANSMITTER FREQUENCY ADJUSTMENT

Connect a frequency counter through a suit-
 able attenuator to the antenna connector J601.
 Key the transmitter.
 Select one by one, the channels and read
 their frequencies.
 Adjust L701 for best frequency tracking on
 all channels.

Requirement: $F = F_{ant} \pm 0.2 \text{ ppm}$,
 $\text{ppm} = \text{parts per million} = 10^{-6}$

**RF POWER OUTPUT, CURRENT CONSUMPTION,
 AND POWER CONTROL**

Connect the Watt meter to the antenna con-
 nector, J601.
 Increase the supply voltage to 13.2 V. The
 voltage is measured directly at the input con-
 nector J910.
 Readjust the PA power control, R221, for
 rated transmitter power (P), 20 W or 5 W.
 Requirement: $P_{nom} \pm 0.2 \text{ dB}$.
 Measure the RF power output at 16 V, 13.2 V
 and 10.8 V.

Requirements (20 W):

CQM5660	S12	S99
Voltage	Power	Current
16.6 V	$\leq 25 \text{ W (ref)}$	$\leq 5.4 \text{ A}$
13.2 V	20 W	$\leq 5.4 \text{ A}$
10.8 V	$\geq 20 \text{ W}$	$\leq 5.4 \text{ A}$

Requirements (5 W):

CQM5660	S12	S99
Voltage	Power	Current
16 V	$\leq 6.5 \text{ W}$	$\leq 1.7 \text{ A}$
13.2 V	5 W	$\leq 1.7 \text{ A}$
10.8 V	$\geq 3.5 \text{ W}$	$\leq 1.7 \text{ A}$

MODULATION ADJUSTMENT

Set the power supply voltage to 13.2 V.
 Select the channel having the highest frequen-
 cy. Set R116 to mid-position.
 Connect coax probe 95.0179-00 to test point
 TP701.
 Connect a deviation meter to the coax probe.

 Connect a distortion meter and oscilloscope
 to the deviation meter output.
 Connect a AF generator and an AF Voltmeter
 to the microphone input via a 22 uF capacitor;
 refer to test setup.

Set the AF generator to 1000 Hz.
 Adjust the AF generator output to 1 V r. m. s.
 This voltage is approx. 20 dB above the no-
 minal modulation input level (60% Δf max) to
 ensure full limiting in the modulation proces-
 sor.
 Note the deviation read at TP701.
 Connect the deviation meter to test point
 TP702.
 Adjust R752 (Dev. Bal.) for same deviation
 as measured at TP701.

Disconnect the deviation meter from the coax-probe and connect it through an attenuator to the antenna connector, J601.

Find the AF frequency between 200 Hz and 3000 Hz giving the greatest frequency deviation as read on the deviation meter with the transmitter keyed.

Check the maximum deviation for both positive and negative deviation polarity. At that audio frequency set the maximum frequency deviation Δf_{max} with R116.

Type	Channel spacing	Δf_{max}
CQM5662	30/25 kHz	± 5 kHz
CQM5663	20 kHz	± 4 kHz

Requirement

Difference between + and - deviation: $\leq 10\%$

MODULATION SENSITIVITY AND MODULATION DISTORTION

Set the AF generator frequency to 1000 Hz
Adjust the generator output until 60% of Δf_{max} is obtained on the deviation meter.

CQM5662 : ± 3.0 kHz
CQM5663 : ± 2.4 kHz

Read the AF generator output and measure the modulation distortion on the audio output of the deviation meter.

Requirements:

Modulating signal: 75 mV ± 3 dB

Distortion: $\leq 7\%$

(measured without deemphasis)

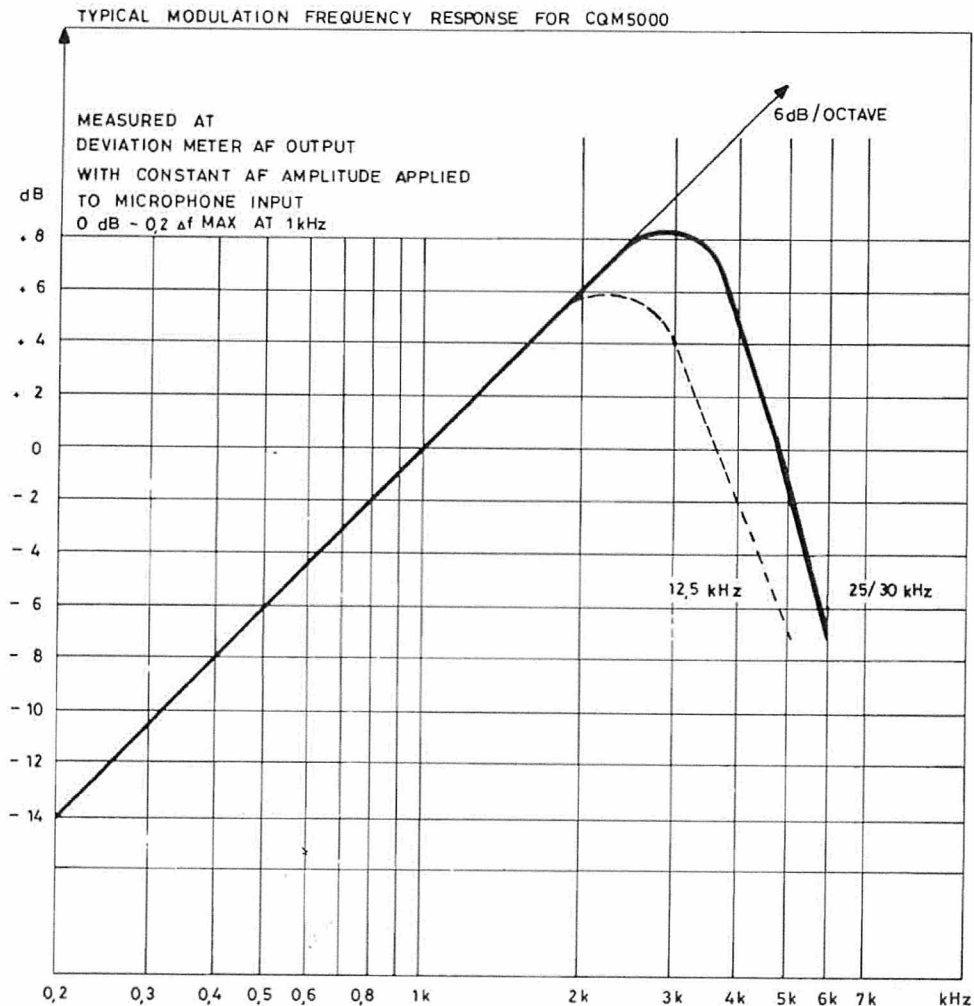

MODULATION FREQUENCY RESPONSE

Set the AF generator to 1000 Hz.

Reduce the AF generator output until a deviation of $0.2 \times \Delta f_{\max}$ is obtained on the deviation meter.

CQM5662 : ± 1.0 kHz

CQM5663 : ± 0.8 kHz

Vary the frequency of the generator and note the deviation changes as referred to the 1000 Hz value.

Requirement :

Within the frequency range 400–2700 Hz the frequency characteristic shall lie within +1 dB/–1.5 dB related to a 6 dB/octave characteristic.

With 6 kHz modulation frequency the deviation shall be attenuated at least 6 dB below the 1 kHz value.

CHANNEL FREQUENCY SYNTHESIZER

FS5661 and FS5662

The frequency synthesizer generates up to 12 channel frequencies for a STORNOPHONE 5000 operating in the 420 - 470 MHz band. It is built on a printed circuit board which mounts in the top section of the radio set. There are two versions of the board, a single channel board, FS5661 and a multichannel board FS5662. The frequency of the single channel board is set by putting a binary code directly on the programmable divider input while the multichannel board channels are selected with a channel selector and a Frequency Control unit, FC5001. The channel selector is mounted directly on the board and protrudes through the front panel, and the Frequency Control module FC5001, fits into the cast shield which is placed over the main section of the synthesizer board. A metal shield is placed underneath the os-

cillator and mixer sections of the board.

All circuitry can be accessed and operated for repair and maintenance without the shields and with the FC5001 in its socket.

The Frequency Synthesizer board also carries all interconnections between the tone modules and the RF module and has two connectors at the rear for accessories and power supply cables.

The channel programming is contained in a 256 bit PROM placed in a socket on the Frequency Control module. The PROM can be field programmed if the necessary programming equipment is available. Programming equipment and procedures must be approved by STORNO and the PROM manufacturer, refer to the Channel Programming Instructions.

CIRCUIT DESCRIPTION

The Frequency Synthesizer generates the local oscillator injection for the receiver and a modulated exciter signal for the transmitter. The circuit is a single-loop phase-locked frequency generator.

The synthesizer frequency is controlled by three crystals, one reference crystal and two mixer crystals, and by a PROM.

The synthesizer can be reprogrammed for new frequencies if these are within the maximum frequency spread of the STORNOPHONE 5000.

Two voltage controlled oscillators (VCO) are generating the signals which are used as injection for the receiver mixer and excitation signal for the transmitter. The frequency of

each VCO can be preset to any frequency within the band by a variable capacitor, and the fine adjustment is controlled by a variable capacitance diode, varicap, and the phase detector output. The control voltage for the varicaps is filtered in a loop integrating filter. The TX VCO has an additional varicap which is used to modulate the transmitter.

The Push-to-talk switch controls a transistor switch, which switches the supply voltage between the RX VCO and the TX VCO.

The output signal from the VCO's are fed into a buffer amplifier which protects the VCO from load changes.

The buffer amplifier's output is applied to an

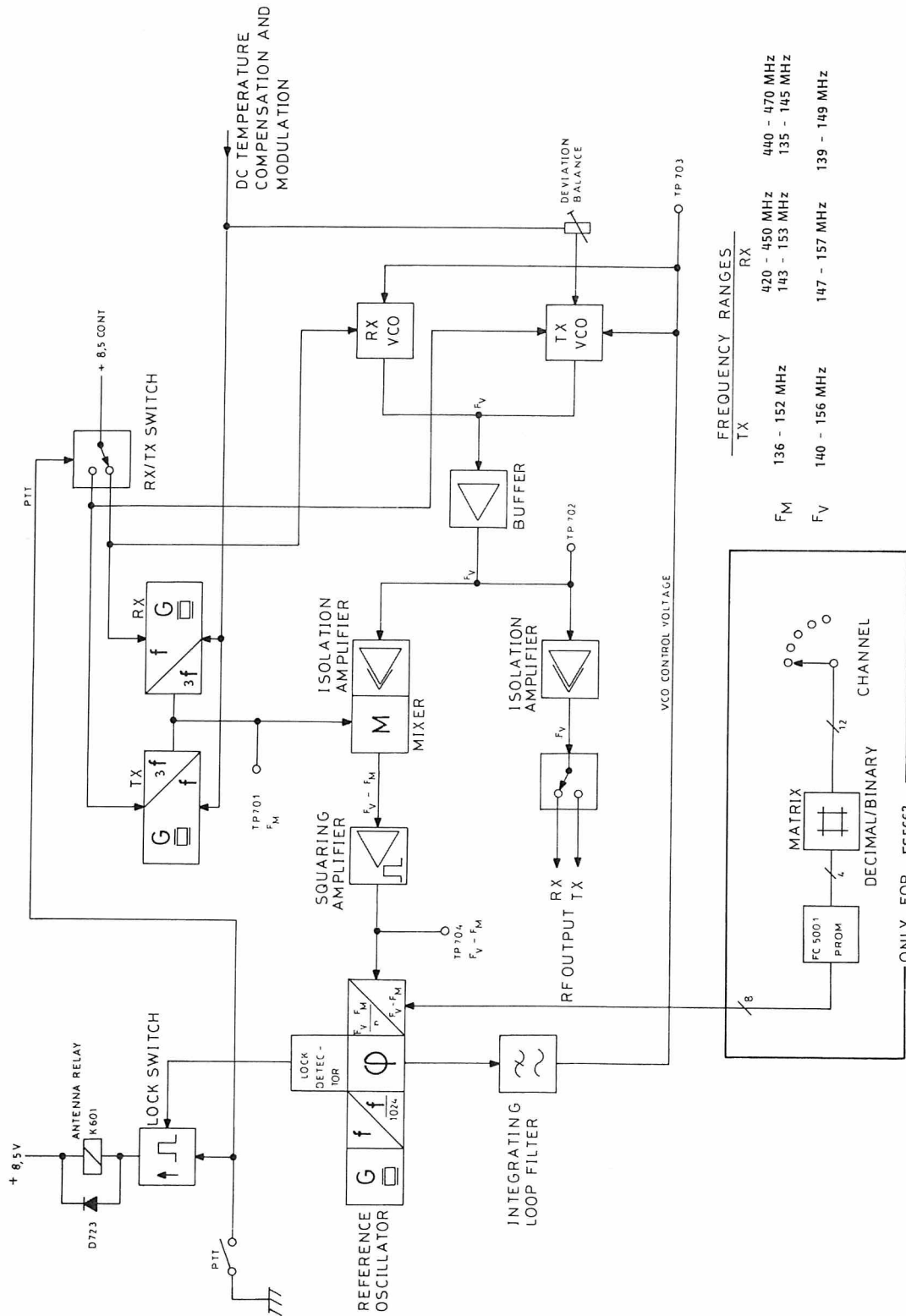

BLOCK DIAGRAM FS5661, FS5662

D402. 934

isolation amplifier and a diode switch before entering the RF board.

The buffer amplifier also connects to another isolation amplifier via a resistive attenuator and feeds the signal to the synthesizer mixer.

The synthesizer mixer mixes the VCO signal and the crystal oscillator signal to a frequency which is within the dividing capability of the programmable divider.

Separate crystal oscillators are used in the receive and transmit mode, respectively, and they are both third mode oscillators.

A temperature compensating voltage is applied to the crystal oscillators only in the 5 p.p.m. version. This voltage is kept constant in the 10 p.p.m. version by cutting a diode on the RF board.

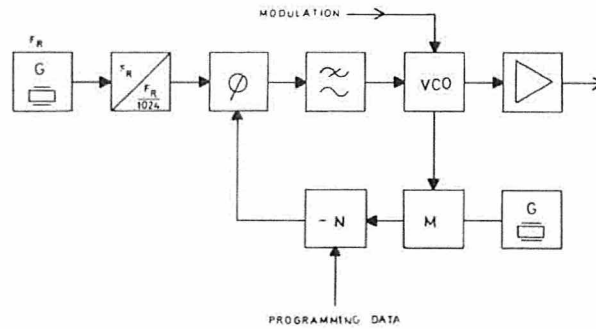

Fig. 2. Phase Locked loop Principle

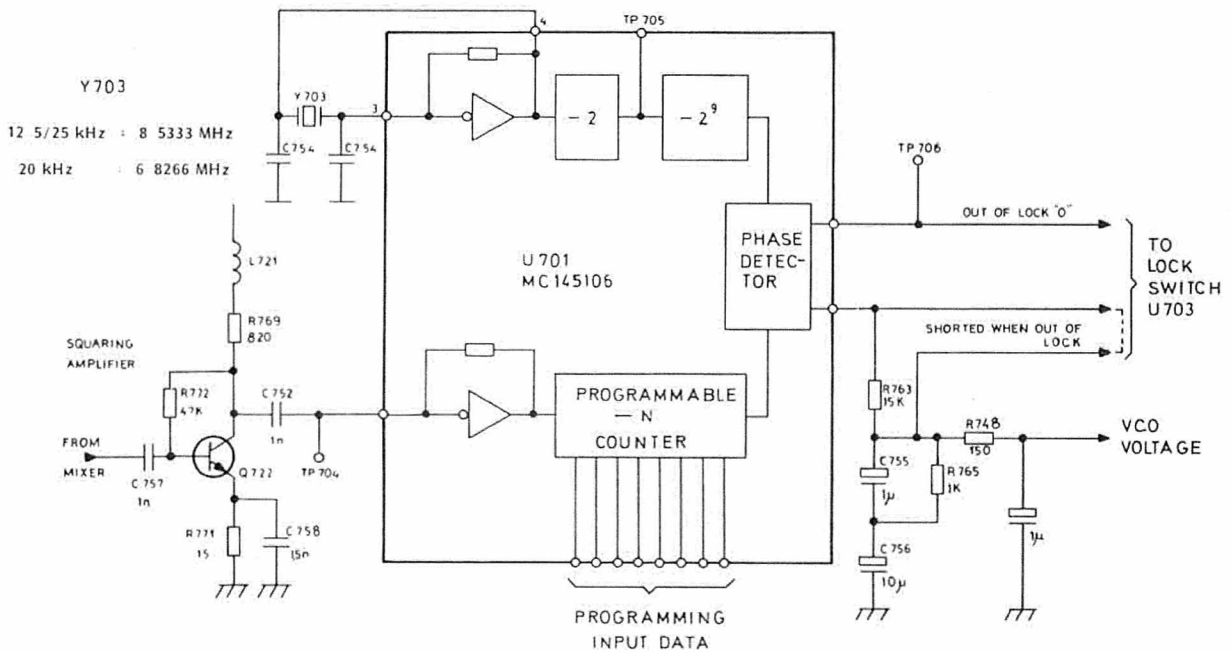
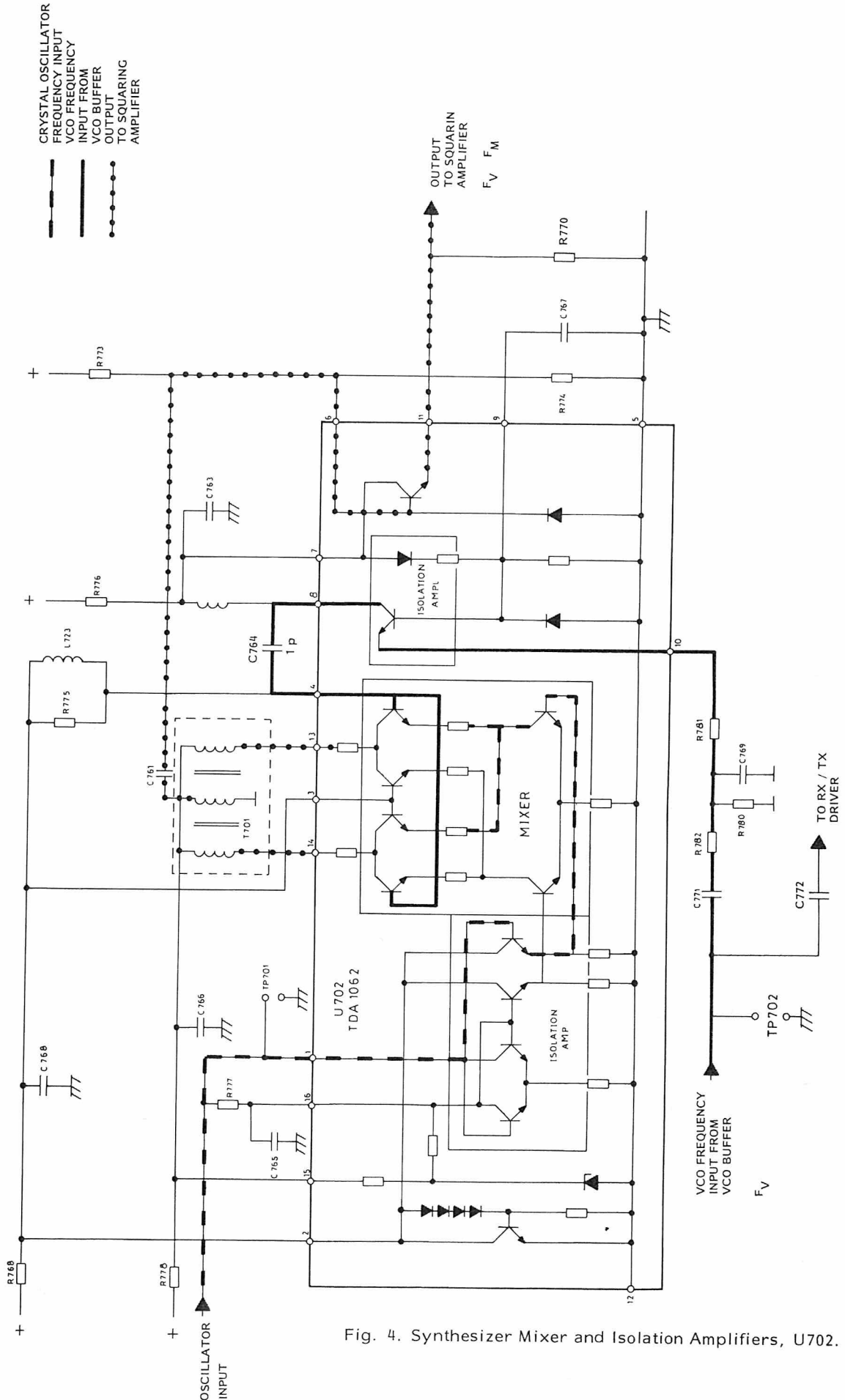

FIG. 3. REFERENCE OSCILLATOR, DIVIDER, AND PHASE DETECTOR



CRYSTAL OSCILLATOR
 FREQUENCY INPUT
 VCO FREQUENCY
 INPUT FROM
 VCO BUFFER
 OUTPUT
 TO SQUARE
 WAVE
 AMPLIFIER

Fig. 4. Synthesizer Mixer and Isolation Amplifiers, U702.

The output from the synthesizer mixer is fed to a squaring amplifier which drives the programmable divider and this divides the frequency by 256 to 511 depending on the logic levels on the 8-bit binary control input. The input frequency range for the divider differs according to the channel spacing and is shown in fig. 3.

The phase detector produces a waveform with variable duty cycle which depends on the phase and frequency difference between its two input signals. The operating frequency range of the phase detector is 1.7 kHz to 3.5 kHz and it depends on the channel spacing.

The reference frequency is generated in a crystal oscillator whose output is divided by 1024 and applied to the phase detector.

The output from the phase detector passes through a passive integrating filter which produces a DC voltage proportional to the duty cycle of the phase detector output. This voltage adjusts the frequency of the VCO.

An out-of-lock circuit inhibits the transmitter when the synthesizer loop is out of lock and hunting for the frequency.

The transmitter modulation is applied simul-

taneously to the transmitter mixer-oscillator and the VCO. The modulation bandwidth also covers sub-audio frequencies used for channel guard (pilot tones). The frequency deviation balance adjustment equalizes the deviation on both oscillators to ascertain low distortion and low noise reference side bands during modulation of the synthesizer because it is operating with a relatively large loop bandwidth.

The frequency control module, FC5001, is built on a separate wiring board which mounts on top of the synthesizer shield. This module converts the BCD-code (4 bits) from the channel selector to an 8-bit binary code for the programmable divider in the synthesizer loop. These 8-bit codes are programmed into a PROM (Programmable Read Only Memory) and are dividing factors expressed in hexadecimal codes.

On the FC5001 is a 5-Volt regulator which supplies the voltage for the PROM. When the PTT button is pushed the transistor Q801 converts the PTT voltage level to TTL level and puts a logic "0" on the MSB (Most Significant Bit) on the address input of the PROM. This selects the PROM code for the corresponding transmitter channel. The PROM outputs have open collectors with external pull-up resistors.

TECHNICAL SPECIFICATIONS

Supply Voltage

+8.5 Volts regulated
+13.2 Volts unregulated

Current Consumption

max. 80 mA (+8.5 V)
max. 200 mA (+13.2 V)

Channel Spacing

30/25 kHz
20 kHz

Modulation Input

0.75 V r.m.s. ± 2 dB
 $\Delta f = 60\%$, $f_{\text{mod}} = 1$ kHz

Modulation Bandwidth

70 - 3000 Hz

Modulation Distortion

70 - 300 Hz: <5%
1 kHz: <4%

DC Temperature Stabilization Voltage

25°C = 6 V ± 10% (reference)
 -30°C = +350 mV ± 10%
 -10°C = -50 mV ± 10%
 +60°C = +50 mV ± 10%

The voltage characteristic is approximately linear between these points.

RF Output Level

4 mW ± 1 mW
 (open collector output connected to tuned circuit)

TX Output Frequency Range

420 - 470 MHz (VCO)

RX Output Frequency Range (VCO)

420 - 450 MHz: 147 - 157 MHz
 440 - 470 MHz: 139 - 149 MHz

Frequency Stability

5 p.p.m. or 10 p.p.m. (p.p.m. = 10⁻⁶)

Reference Crystal Frequency

20 kHz: 10.240 MHz
 12.5/25 kHz: 12.800 MHz

Signal-to-Noise Ratio (S/N)

>100 dB
 $\Delta f = 25$ kHz, BW (Bandwidth) = 10 kHz

Spurious Attenuation

>85 dB

Lock Time

<30 m sec.
 for 1 MHz step

Logic Control Level

LOW = <2 V
 HIGH = >6 V
 8 bit binary positive logic with built-in pull down resistors, $I_{IN} = 175$ uA per bit.

Temperature range

-30°C to +60°C

Dimensions

135 x 190 x 45 mm (BxDxH)

Weight

PC board: 150 g
 Shield: 75 g

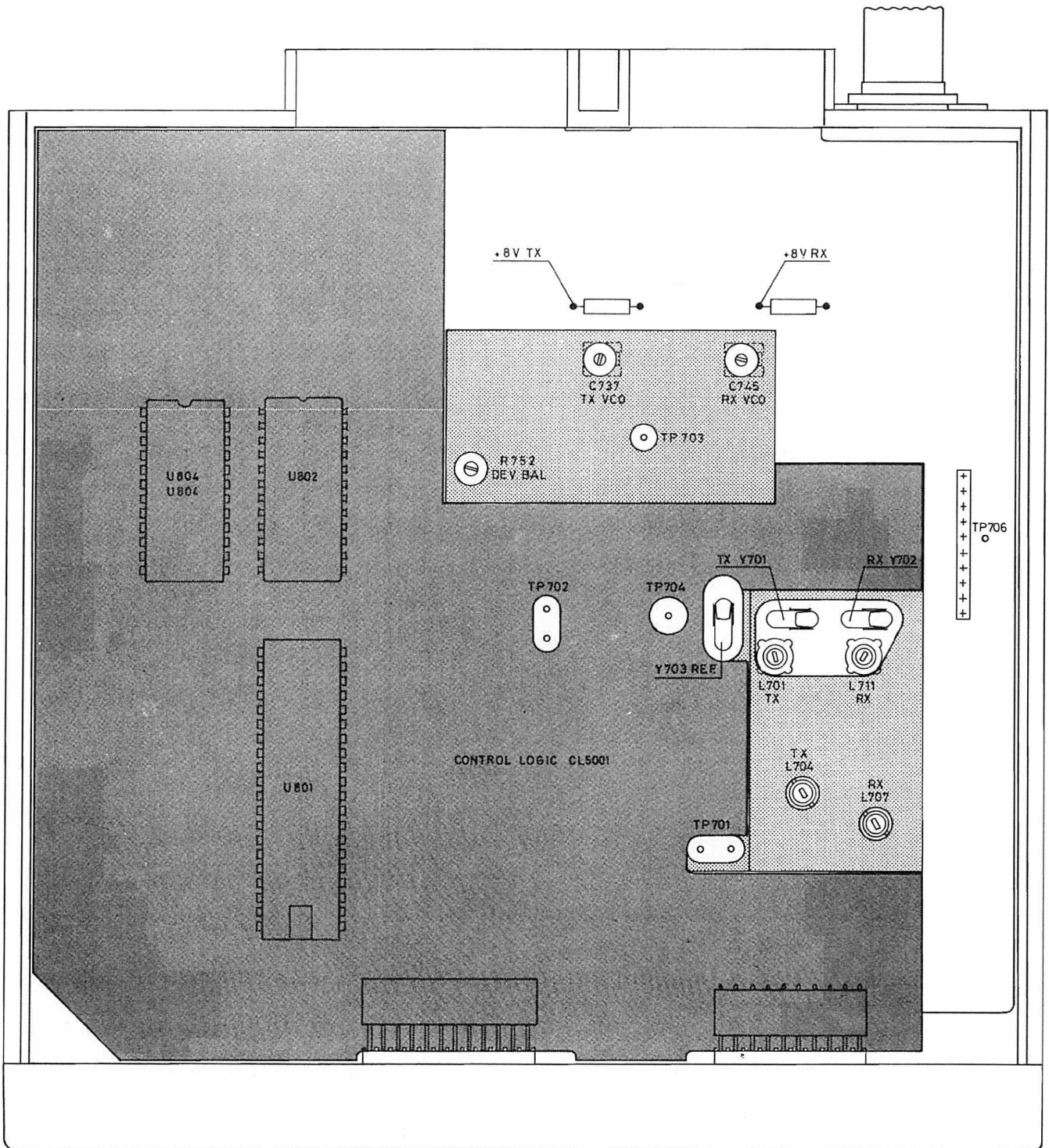

ADJUSTABLE COMPONENTS AND TEST POINTS ON CQM5000SXXS99

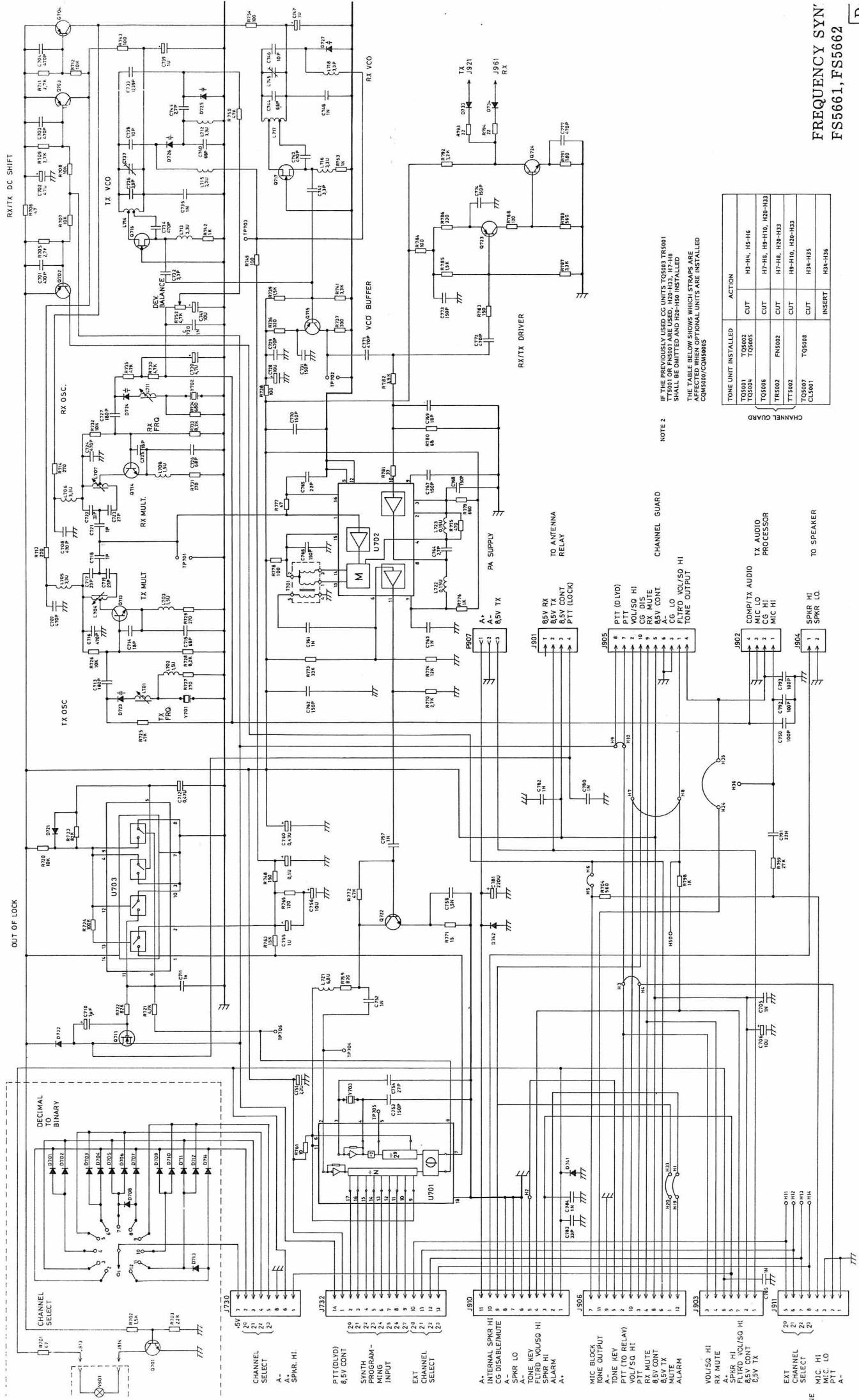

NOTE 2
IF THE PREVIOUSLY USED CG UNITS TO5003, TO5001, TO5001 OR FN5007 ARE USED, H28-H33, H7-H8 SHOULD BE OMITTED AND H30-H33 INSTALLED. ADDITIONAL UNITS ARE INSTALLED COM-5006/COM-5005

CHANNEL GUARD	TO NE UNIT INSTALLED	ACTION
	TO5002	CUT
	TO5005	CUT
	TO5004	CUT
	TO5006	CUT
	FN5002	CUT
	TO5002	CUT
	TO5007	CUT
	CL5001	CUT
	TO5008	INSERT
	H30-H33	INSERT

CHANNEL GUARD

TX AUDIO PROCESSOR

TO SPEAKER

TO ANTENNA RELAY

PA SUPPLY

8.5V TX

PTT (LOCK)

8.5V CONT

8.5V TX

8.5V RX

PTT (LOCK)

8.5V CONT

8.5V TX

8.5V RX

PTT (LOCK)

8.5V CONT

8.5V TX

8.5V RX

PTT (LOCK)

8.5V CONT

8.5V TX

8.5V RX

PTT (LOCK)

8.5V CONT

8.5V TX

8.5V RX

PTT (LOCK)

8.5V CONT

8.5V TX

8.5V RX

PTT (LOCK)

8.5V CONT

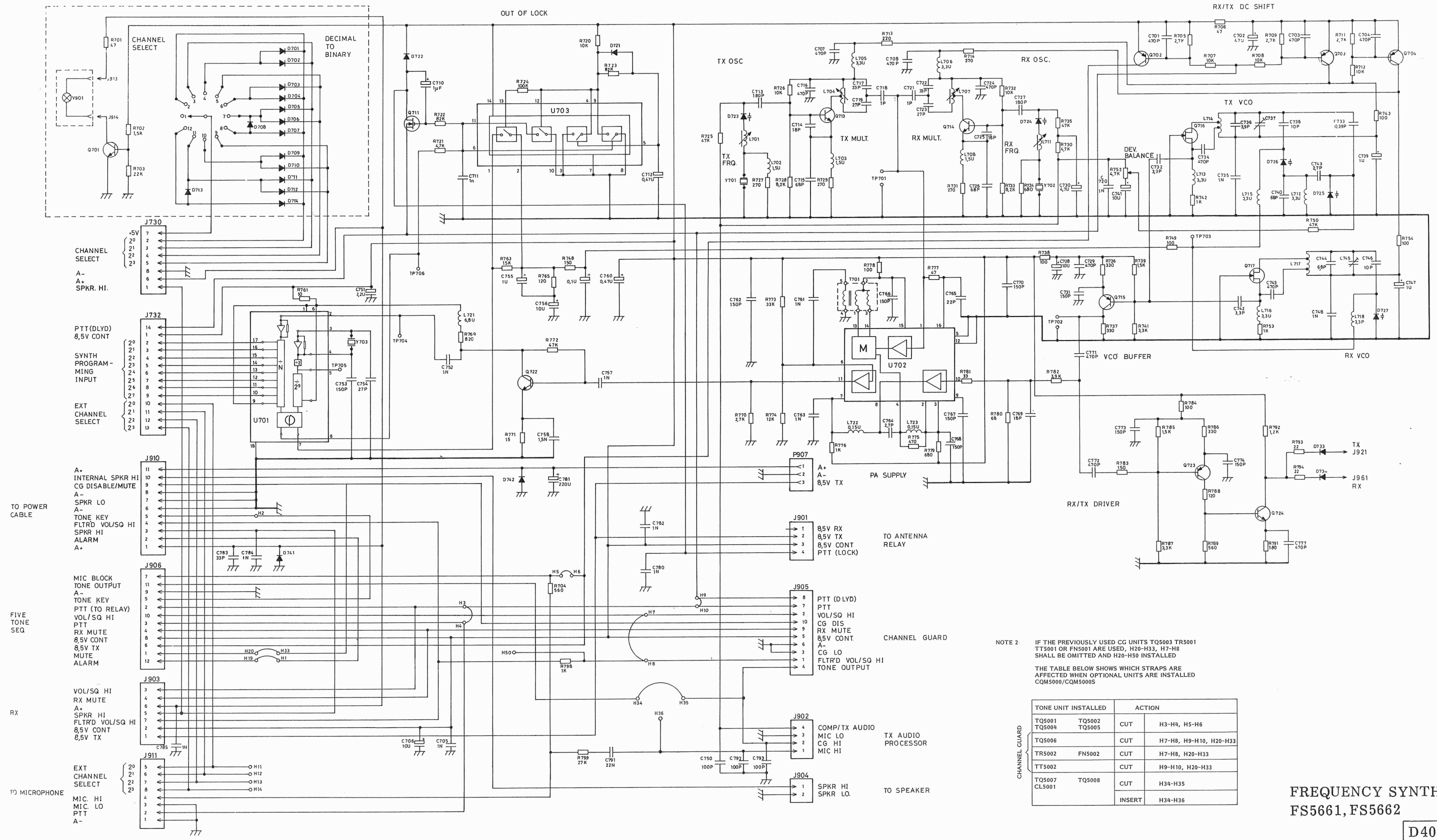

FREQUENCY SYNTHESIZER
FS5661, FS5662

Nº	CODE	DATA
C701	19A700233P5	470 pF Capacitor Ceramic
C702	19J706005P3	47 uF Capacitor Electrolytic
C703	19A700233P5	470 pF Capacitor Ceramic
C704	19A700233P5	470 pF Capacitor Ceramic
C705	19A700233P7	1 nF Capacitor Ceramic
C706	19A700003P7	10 uF Capacitor Tantalum
C707	19A700233P5	470 pF Capacitor Ceramic
C708	19A700233P5	470 pF Capacitor Ceramic
C711	19A700003P1	0.1 uF Capacitor Tantalum
C712	19A700003P5	2.2 uF Capacitor Tantalum
C713	19A700235P28	180 pF Capacitor Ceramic
C714	19J706256P202	18 pF N1500 Capacitor Ceramic
C715	19J706256P205	68 pF N1500 Capacitor Ceramic
C716	19A700233P5	470 pF Capacitor Ceramic
C717	19A700235P19	33 pF Capacitor Ceramic
C718	19A700235P7	3.3 pF Capacitor Ceramic
C719	19A700235P18	27 pF Capacitor Ceramic
C720	19A700233P7	1 nF Capacitor Ceramic
C721	19A700235P7	3.3 pF Capacitor Ceramic
C722	19A700235P19	33 pF Capacitor Ceramic
C723	19A700235P18	27 pF Capacitor Ceramic
C724	19A700233P5	470 pF Capacitor Ceramic
C725	19J706256P202	18 pF N1500 Capacitor Ceramic
C726	19J706256P205	68 pF N1500 Capacitor Ceramic
C727	19A700235P28	180 pF Capacitor Ceramic
C728	19A700003P7	10 uF Capacitor Tantalum
C729	19A700233P5	470 pF Capacitor Ceramic
C730	19A700003P6	4.7 uF Capacitor Tantalum
C731	19A700233P2	150 pF Capacitor Ceramic
C732	19A700235P7	3.3 pF Capacitor Ceramic
C733	19A700013P8	0.39 pF Capacitor Phenolic
C734	19A700233P5	470 pF Capacitor Ceramic
C735	19A700233P7	1 nF Capacitor Ceramic
C736	19A700235P8	3.9 pF Capacitor Ceramic
C737	19J706003P1	1.8-10 pF Capacitor Variable
C738	19A700235P13	10 pF Capacitor Ceramic
C739	19A700003P4	1 uF Capacitor Tantalum
C740	19A700235P23	68 pF Capacitor Ceramic
C741	19A700003P7	10 uF Capacitor Tantalum
C742	19A700235P7	3.3 pF Capacitor Ceramic
C743	19A700233P5	470 pF Capacitor Ceramic
C744	19A700235P11	6.8 pF Capacitor Ceramic
C745	19J706003P1	1.8-10 pF Capacitor Variable
C746	19A700235P13	10 pF Capacitor Ceramic
C747	19A700003P4	1 uF Capacitor Tantalum
C748	19A700233P7	1 nF Capacitor Ceramic
C749	19A700235P8	3.9 pF Capacitor Ceramic

Nº	CODE	DATA
C750	19A700233P1	100 pF Capacitor Ceramic
C751	19A700003P5	2.2 uF Capacitor Tantalum
C752	19A700233P7	1 nF Capacitor Ceramic
C753	19A700233P2	150 pF Capacitor Ceramic
C754	19A700235P18	27 pF Capacitor Ceramic
C755	19A700003P4	1 uF Capacitor Tantalum
C756	19A700003P7	10 uF Capacitor Tantalum
C757	19A700233P7	1 nF Capacitor Ceramic
C758	19A700233P8	1.5 nF Capacitor Ceramic
C759	19A700003P4	1 uF Capacitor Tantalum
C760	19A700003P3	0.47 uF Capacitor Tantalum
C761	19A700233P7	1 nF Capacitor Ceramic
C762	19A700233P2	150 pF Capacitor Ceramic
C763	19A700233P7	1 nF Capacitor Ceramic
C764	19A700235P6	2.7 pF Capacitor Ceramic
C765	19A700233P2	150 pF Capacitor Ceramic
C766	19A700233P2	150 pF Capacitor Ceramic
C767	19A700233P2	150 pF Capacitor Ceramic
C768	19A700233P2	150 pF Capacitor Ceramic
C769	19A700235P16	18 pF Capacitor Ceramic
C770	19A700233P2	150 pF Capacitor Ceramic
C771	19A700233P5	470 pF Capacitor Ceramic
C772	19A700233P5	470 pF Capacitor Ceramic
C773	19A700233P2	150 pF Capacitor Ceramic
C774	19A700233P2	150 pF Capacitor Ceramic
C776	19A700235P13	10 pF Capacitor Ceramic
C777	19A700233P5	470 pF Capacitor Ceramic
C780	19A700233P7	1 nF Capacitor Ceramic
C781	19J706005P5	220 uF Capacitor Electrolytic
C782	19A700233P7	1 nF Capacitor Ceramic
C783	19A700235P19	33 pF Capacitor Ceramic
C784	19A700233P7	1 nF Capacitor Ceramic
C785	19A700233P7	1 nF Capacitor Ceramic
C791	19J706261P1	22 nF Capacitor Polyester
C792	19A700233P1	100 pF Capacitor Ceramic
C793	19A700233P1	100 pF Capacitor Ceramic
D721	19A700028P1	1N4148 Diode Silicon
D722	19A700028P1	1N4148 Diode Silicon
D723	19A706262P1	Variable Cap. Diode
D724	19J706262P1	Variable Cap. Diode

FREQUENCY SYNTHESIZER FS5661

X403.049

No	CODE	DATA
D725	19A700073P1	BB409 Variable Cap. Diode
D726	19A700073P1	BB409 Variable Cap. Diode
D727	19A700073P1	BB409 Variable Cap. Diode
D733	19J706006P2	BA282 Diode
D734	19J706006P2	BA282 Diode
D741	19J706026P1	1N5401 Diode Silicon
D742	19J706026P1	1N5401 Diode Silicon
J730	19J706215P108	Male Connector
J732	19J706215P114	Male Connector
J901	19J706214P4	Male Connector
J902	19J706214P4	Male Connector
J903	19J706214P7	Male Connector
J904	19A700072P28	Male Connector
J905	19A700072P9	Male Connector
J906	19A700072P11	Male Connector
J907	19A700102P21	Female Connector
J910	19J706223P11	Male Connector
J911	19J706223P8	Male Connector
J921	19J706219P1	Male Connector
J961	19J706219P1	Male Connector
L701	19J706029P4	Variable Coil
L702	19A700024P15	1.5 uH Coil
L703	19A700024P15	1.5 uH Coil
L704	19J706083P1	Coil
L705	19A700024P19	3.3 uH Coil
L706	19A700024P19	3.3 uH Coil
L707	19J706083P1	Variable Coil
L708	19A700024P15	1.5 uH Coil
L711	19J706029P4	Variable Coil
L712	19A700024P19	3.3 uH Coil
L713	19A700024P19	3.3 uH Coil
L714	19J706258P1	Coil
L715	19A700024P19	3.3 uH Coil
L716	19A700024P19	3.3 uH Coil
L717	19J706258P1	Coil
L718	19A700024P19	3.3 uH Coil
L721	19A700024P23	6.8 uH Coil
L722	19A700024P3	0.15 uH Coil
L723	19A700024P3	0.15 uH Coil
Q702	19A700020P1	BC558 Transistor
Q703	19A700020P1	BC558 Transistor
Q704	19A700020P1	BC558 Transistor
Q711	19A700017P2	BC548 Transistor
Q713	19J706283P1	BFR54 Transistor
Q714	19J706283P1	BFR54 Transistor
Q715	19J706264P1	BF414 Transistor

No	CODE	DATA
Q716	19J706038P1	2N5245 Transistor
Q717	19J706038P1	2N5245 Transistor
Q722	19J706146P1	BF357S Transistor
Q723	19J706164P1	BF414 Transistor
Q724	19J706146P1	BF357S Transistor
R704	19A700019P34	560 ohm Resistor Depos.
R705	19A700019P42	2.7 Kohm Resistor Depos.
R706	19A700019P21	47 ohm Resistor Depos.
R707	19A700019P49	10 Kohm Resistor Depos.
R708	19A700019P49	10 Kohm Resistor Depos.
R709	19A700019P42	2.7 Kohm Resistor Depos.
R711	19A700019P42	2.7 Kohm Resistor Depos.
R712	19A700019P49	10 Kohm Resistor Depos.
R713	19A700019P17	22 ohm Resistor Depos.
R714	19A700019P17	22 ohm Resistor Depos.
R720	19A700019P37	1 Kohm Resistor Depos.
R721	19A700019P45	4.7 Kohm Resistor Depos.
R722	19A700019P60	82 Kohm Resistor Depos.
R723	19A700019P58	56 Kohm Resistor Depos.
R724	19A700019P49	10 Kohm Resistor Depos.
R725	19A700019P57	47 Kohm Resistor Depos.
R726	19A700019P49	10 Kohm Resistor Depos.
R727	19A700019P30	270 ohm Resistor Depos.
R728	19A700019P48	8.2 Kohm Resistor Depos.
R729	19A700019P30	270 ohm Resistor Depos.
R730	19A700019P45	4.7 Kohm Resistor Depos.
R732	19A700019P49	10 Kohm Resistor Depos.
R733	19A700019P48	8.2 Kohm Resistor Depos.
R734	19A700019P35	680 ohm Resistor Depos.
R735	19A700029P57	47 Kohm Resistor Depos.
R736	19A700029P31	330 ohm Resistor Depos.
R737	19A700019P31	330 ohm Resistor Depos.
R738	19A700019P25	100 ohm Resistor Depos.
R739	19A700019P39	1.5 Kohm Resistor Depos.
R741	19A700019P43	3.3 Kohm Resistor Depos.
R742	19A700019P37	1 Kohm Resistor Depos.
R743	19A700019P25	100 ohm Resistor Depos.
R748	19A700019P27	150 ohm Resistor Depos.
R749	19A700019P25	100 ohm Resistor Depos.
R750	19A700019P57	47 Kohm Resistor Depos.
R752	19A700016P3	4.7 Kohm Resistor Variable

FREQUENCY SYNTHESIZER FS5661

X403.049

Nº	CODE	DATA
C701	19A700233P5	470 pF Capacitor Ceramic
C702	19J706005P3	47 uF Capacitor Electrolytic
C703	19A700233P5	470 pF Capacitor Ceramic
C704	19A700233P5	470 pF Capacitor Ceramic
C705	19A700233P7	1 nF Capacitor Ceramic
C706	19A700003P7	10 uF Capacitor Tantalum
C707	19A700233P5	470 pF Capacitor Ceramic
C708	19A700233P5	470 pF Capacitor Ceramic
C711	19A700003P1	0.1 uF Capacitor Tantalum
C712	19A700003P5	2.2 uF Capacitor Tantalum
C713	19A700233P28	180 pF Capacitor Ceramic
C714	19J706256P202	18 pF N1500 Capacitor Ceramic
C715	19J706256P205	68 pF N1500 Capacitor Ceramic
C716	19A700233P5	470 pF Capacitor Ceramic
C717	19A700233P19	33 pF Capacitor Ceramic
C718	19A700233P7	3.3 pF Capacitor Ceramic
C719	19A700233P18	27 pF Capacitor Ceramic
C720	19A700233P7	1 nF Capacitor Ceramic
C721	19A700233P7	3.3 pF Capacitor Ceramic
C722	19A700233P19	27 pF Capacitor Ceramic
C723	19A700233P18	27 pF Capacitor Ceramic
C724	19A700233P5	470 pF Capacitor Ceramic
C725	19J706256P202	18 pF N1500 Capacitor Ceramic
C726	19J706256P205	68 pF N1500 Capacitor Ceramic
C727	19A700233P28	180 pF Capacitor Ceramic
C728	19A700003P7	10 uF Capacitor Tantalum
C729	19A700233P5	470 pF Capacitor Ceramic
C730	19A700003P6	4.7 uF Capacitor Tantalum
C731	19A700233P2	150 pF Capacitor Ceramic
C732	19A700233P7	3.3 pF Capacitor Ceramic
C733	19A700013P8	0.39 pF Capacitor Phenolic
C734	19A700233P5	470 pF Capacitor Ceramic
C735	19A700233P7	1 nF Capacitor Ceramic
C736	19A700233P8	3.9 pF Capacitor Ceramic
C737	19J706003P1	1.8-10 pF Capacitor Variable
C738	19A700233P13	10 pF Capacitor Ceramic
C739	19A700003P4	1 uF Capacitor Tantalum
C740	19A700233P23	68 pF Capacitor Ceramic
C741	19A700003P7	10 uF Capacitor Tantalum
C742	19A700233P7	3.3 pF Capacitor Ceramic
C743	19A700233P5	470 pF Capacitor Ceramic
C744	19A700233P11	6.8 pF Capacitor Ceramic
C745	19J706003P1	1.8-10 pF Capacitor Variable
C746	19A700233P13	10 pF Capacitor Ceramic
C747	19A700003P4	1 uF Capacitor Tantalum
C748	19A700233P7	1 nF Capacitor Ceramic

Nº	CODE	DATA
C749	19A700233P8	3.9 pF Capacitor Ceramic
C750	19A700233P1	100 pF Capacitor Ceramic
C751	19A700003P5	2.2 uF Capacitor Tantalum
C752	19A700233P7	1 nF Capacitor Ceramic
C753	19A700233P2	150 pF Capacitor Ceramic
C754	19A700233P18	27 pF Capacitor Ceramic
C755	19A700003P4	1 uF Capacitor Tantalum
C756	19A700003P7	10 uF Capacitor Tantalum
C757	19A700233P7	1 nF Capacitor Ceramic
C758	19A700233P8	1.5 nF Capacitor Ceramic
C759	19A700003P4	1 uF Capacitor Tantalum
C760	19A700003P3	0.47 uF Capacitor Tantalum
C761	19A700233P7	1 nF Capacitor Ceramic
C762	19A700233P2	150 pF Capacitor Ceramic
C763	19A700233P7	1 nF Capacitor Ceramic
C764	19A700233P6	2.7 pF Capacitor Ceramic
C765	19A700233P2	150 pF Capacitor Ceramic
C766	19A700233P2	150 pF Capacitor Ceramic
C767	19A700233P2	150 pF Capacitor Ceramic
C768	19A700233P2	150 pF Capacitor Ceramic
C769	19A700233P16	18 pF Capacitor Ceramic
C770	19A700233P2	150 pF Capacitor Ceramic
C771	19A700233P5	470 pF Capacitor Ceramic
C772	19A700233P5	470 pF Capacitor Ceramic
C773	19A700233P2	150 pF Capacitor Ceramic
C774	19A700233P2	150 pF Capacitor Ceramic
C776	19A700233P13	10 pF Capacitor Ceramic
C777	19A700233P5	470 pF Capacitor Ceramic
C780	19A700233P7	1 nF Capacitor Ceramic
C781	19J706005P5	220 uF Capacitor Electrolytic
C782	19A700233P7	1 nF Capacitor Ceramic
C783	19A700233P19	33 pF Capacitor Ceramic
C784	19A700233P7	1 nF Capacitor Ceramic
C785	19A700233P7	1 nF Capacitor Ceramic
C791	19J706261P1	22 nF Capacitor Polyester
C792	19A700233P1	100 pF Capacitor Ceramic
C793	19A700233P1	100 pF Capacitor Ceramic
D701	19A700028P1	1N4148 Diode Silicon
D702	19A700028P1	1N4148 Diode Silicon
D703	19A700028P1	1N4148 Diode Silicon

FREQUENCY SYNTHESIZER FS5662

X403.050

Nº	CODE	DATA
D704	19A700028P1	1N4148 Diode Silicon
D705	19A700028P1	1N4148 Diode Silicon
D706	19A700028P1	1N4148 Diode Silicon
D707	19A700028P1	1N4148 Diode Silicon
D708	19A700028P1	1N4148 Diode Silicon
D709	19A700028P1	1N4148 Diode Silicon
D710	19A700028P1	1N4148 Diode Silicon
D711	19A700028P1	1N4148 Diode Silicon
D712	19A700028P1	1N4148 Diode Silicon
D713	19A700028P1	1N4148 Diode Silicon
D714	19A700028P1	1N4148 Diode Silicon
D721	19A700028P1	1N4148 Diode Silicon
D722	19A700028P1	1N4148 Diode Silicon
D723	19A706262P1	Variable Cap. Diode
D724	19J706262P1	Variable Cap. Diode
D725	19A700073P1	BB409 Variable Cap. Diode
D726	19A700073P1	BB409 Variable Cap. Diode
D727	19A700073P1	BB409 Variable Cap. Diode
D733	19J706006P2	BA282 Diode
D734	19J706006P2	BA282 Diode
D741	19J706026P1	1N5401 Diode Silicon
D742	19J706026P1	1N5401 Diode Silicon
J730	19J706215P108	Male Connector
J732	19J706215P114	Male Connector
J901	19J706214P4	Male Connector
J902	19J706214P4	Male Connector
J903	19J706214P4	Male Connector
J904	19A700072P28	Male Connector
J905	19A700072P9	Male Connector
J906	19A700072P11	Male Connector
J907	19A700102P21	Female Connector
J910	19J706223P11	Male Connector
J911	19J706223P8	Male Connector
J921	19J706219P1	Male Connector
J961	19J706219P1	Male Connector
L701	19J706029P4	Variable Coil
L702	19A700024P15	1.5 uH Coil
L703	19A700024P15	1.5 uH Coil
L704	19J706083P1	Coil
L705	19A700024P19	3.3 uH Coil
L706	19A700024P19	3.3 uH Coil
L707	19J706083P1	Variable Coil
L708	19A700024P15	1.5 uH Coil
L711	19J706029P4	Variable Coil
L712	19A700024P19	3.3 uH Coil
L713	19A700024P19	3.3 uH Coil

Nº	CODE	DATA
L714	19J706258P1	Coil
L715	19A700024P19	3.3 uH Coil
L716	19A700024P19	3.3 uH Coil
L717	19J706258P1	Coil
L718	19A700024P19	3.3 uH Coil
L721	19A700024P23	6.8 uH Coil
L722	19A700024P3	0.15 uH Coil
L723	19A700024P3	0.15 uH Coil
Q701	19A700017P1	BC548 Transistor
Q702	19A700020P1	BC558 Transistor
Q703	19A700020P1	BC558 Transistor
Q704	19A700020P1	BC558 Transistor
Q711	19A700017P2	BC548 Transistor
Q713	19J706283P1	BFR54 Transistor
Q714	19J706283P1	BFR54 Transistor
Q715	19J706264P1	BF414 Transistor
Q716	19J706038P1	2N5245 Transistor
Q717	19J706038P1	2N5245 Transistor
Q722	19J706146P1	BF357S Transistor
Q723	19J706146P1	BF414 Transistor
Q724	19J706146P1	BF357S Transistor
R701	19A700019P21	47 ohm Resistor Depos.
R702	19A700019P39	1.5 Kohm Resistor Depos.
R703	19A700019P53	22 Kohm Resistor Depos.
R704	19A700019P34	560 ohm Resistor Depos.
R705	19A700019P42	2.7 Kohm Resistor Depos.
R706	19A700019P21	47 ohm Resistor Depos.
R707	19A700019P49	10 Kohm Resistor Depos.
R708	19A700019P49	10 Kohm Resistor Depos.
R709	19A700019P42	2.7 Kohm Resistor Depos.
R711	19A700019P42	2.7 Kohm Resistor Depos.
R712	19A700019P49	10 Kohm Resistor Depos.
R713	19A700019P17	22 ohm Resistor Depos.
R714	19A700019P17	22 ohm Resistor Depos.
R720	19A700019P37	1 Kohm Resistor Depos.
R721	19A700019P45	4.7 Kohm Resistor Depos.
R722	19A700019P60	82 Kohm Resistor Depos.
R723	19A700019P58	56 Kohm Resistor Depos.
R724	19A700019P49	10 Kohm Resistor Depos.
R725	19A700019P57	47 Kohm Resistor Depos.

FREQUENCY SYNTHESIZER FS5662

X403.050

N ^o	CODE	DATA
R726	19A700019P49	10 Kohm Resistor Depos.
R727	19A700019P30	270 ohm Resistor Depos.
R728	19A700019P48	8.2 Kohm Resistor Depos.
R729	19A700019P30	270 ohm Resistor Depos.
R730	19A700019P45	4.7 Kohm Resistor Depos.
R732	19A700019P49	10 Kohm Resistor Depos.
R733	19A700019P48	8.2 Kohm Resistor Depos.
R734	19A700019P35	680 ohm Resistor Depos.
R735	19A700029P57	47 Kohm Resistor Depos.
R736	19A700029P31	330 ohm Resistor Depos.
R737	19A700019P31	330 ohm Resistor Depos.
R738	19A700019P25	100 ohm Resistor Depos.
R739	19A700019P39	1.5 Kohm Resistor Depos.
R741	19A700019P43	3.3 Kohm Resistor Depos.
R742	19A700019P37	1 Kohm Resistor Depos.
R743	19A700019P25	100 ohm Resistor Depos.
R748	19A700019P27	150 ohm Resistor Depos.
R749	19A700019P25	100 ohm Resistor Depos.
R750	19A700019P57	47 Kohm Resistor Depos.
R752	19A700016P3	4.7 Kohm Resistor Variable
R753	19A700019P37	1 Kohm Resistor Depos.
R754	19A700019P25	100 ohm Resistor Depos.
R761	19A700019P13	10 ohm Resistor Depos.
R763	19A700019P51	15 Kohm Resistor Depos.
R765	19A700019P26	120 ohm Resistor Depos.
R769	19A700019P35	820 ohm Resistor Depos.
R770	19A700019P42	2.7 Kohm Resistor Depos.
R771	19A700019P15	15 ohm Resistor Depos.
R772	19A700019P57	47 Kohm Resistor Depos.
R773	19A700019P55	33 Kohm Resistor Depos.
R774	19A700019P50	12 Kohm Resistor Depos.
R775	19A700019P33	470 ohm Resistor Depos.
R776	19A700010P37	1 Kohm Resistor Depos.
R777	19A700019P21	47 ohm Resistor Depos.
R778	19A700019P25	100 ohm Resistor Depos.
R779	19A700019P35	680 ohm Resistor Depos.
R780	19A700019P23	68 ohm Resistor Depos.
R781	19A700019P19	33 ohm Resistor Depos.
R782	19A700019P44	3.9 Kohm Resistor Depos.
R783	19A700019P27	150 ohm Resistor Depos.
R784	19A700019P25	100 ohm Resistor Depos.
R785	19A700019P39	1.5 Kohm Resistor Depos.
R786	19A700019P31	330 ohm Resistor Depos.
R787	19A700019P43	3.3 Kohm Resistor Depos.
R788	19A700019P26	120 ohm Resistor Depos.
R789	19A700019P34	560 ohm Resistor Depos.
R791	19A700019P28	180 ohm Resistor Depos.

N ^o	CODE	DATA
R792	19A700019P38	1.2 Kohm Resistor Depos.
R793	19A700019P17	22 ohm Resistor Depos.
R794	19A700019P17	22 ohm Resistor Depos.
R798	19A700019P37	1 Kohm Resistor Depos.
R799	19A700019P54	27 Kohm Resistor Depos.
S901	19J706322G1	Channel Switch
T701	19J706284G1	Transformer
U701	19J706263P1	MC145106
U702	19J706238P1	TDA1062 IC
U703	19A700029P44	4066B IC

FREQUENCY SYNTHESIZER FS5662

X403.050

CONTROL LOGIC BOARD

CL5001

CL5001 is a microcomputer controlled logic board used in CQM5000. The logic board interfaces the keyboard and 4-digit LED-display (CP5005), the synthesizer (FS5000), the RF-board through the FS5000/XS5002 board and the tone module (TQ5007/8).

The program ROM U802 determines the functional behavior of the logic while the personality PROM U804 determines the system mode and contains customer specified data such as channel information for the synthesizer and tonetables/ tonecodes for the TQ5007/8.

CIRCUIT DESCRIPTION

The control logic board CL5001 includes the following circuit blocks:

1. Microcomputer U801 and program ROM U802
2. Personality PROM U804
3. Latches for RF-Synthesizer (U806, U807, U810)
4. Keyboard decoder/multiplexer, individual and group tone detector (U805)
5. Attention oscillator (U812)
6. Control inputs from RF5000 through FS5000/XS5002
7. Control outputs to RF5000
8. Control outputs to TQ5007/5008
9. Display interface (U808/9), dimmer and LS-indicator (LED)
10. Voltage regulator (U813/15)

MICROCOMPUTER SYSTEM

Description

The microcomputer system processes all functions and information, and controls the data communication between the different modules of the radio unit and other accessories.

The system consists of a microcomputer U801, type 8035 with a 128 byte RAM memory, a 2-Kbyte EPROM U802 where the program is stored and an address latch U803.

The 8 bit common bus (data and address bus) and the 3 bit address bus interconnects those three devices.

Instruction fetch

- When the EA-pin (External access) goes HIGH, the busses are used for external program instruction fetches.
- The 8 LSB (least significant bits) of the program counter are placed on the common bus and the 3 MSB (most significant bits) on the lower half of port 2 (P20-P21-P22).
- The ALE - pin (address latch enable) indicates a valid address. Just when ALE goes LOW, the address is stored at the output of U803.
- The PSEN-pin (Program Store Enable) indicates that an address is in progress on the busses and just when it goes LOW, the external memory U802 is enabled and the data corresponding to the address are placed at the output of U802.
- The common bus then reverts to input mode (floating) and transfers the data to the microcomputer which accepts its 8 bit content as an instruction or data word.

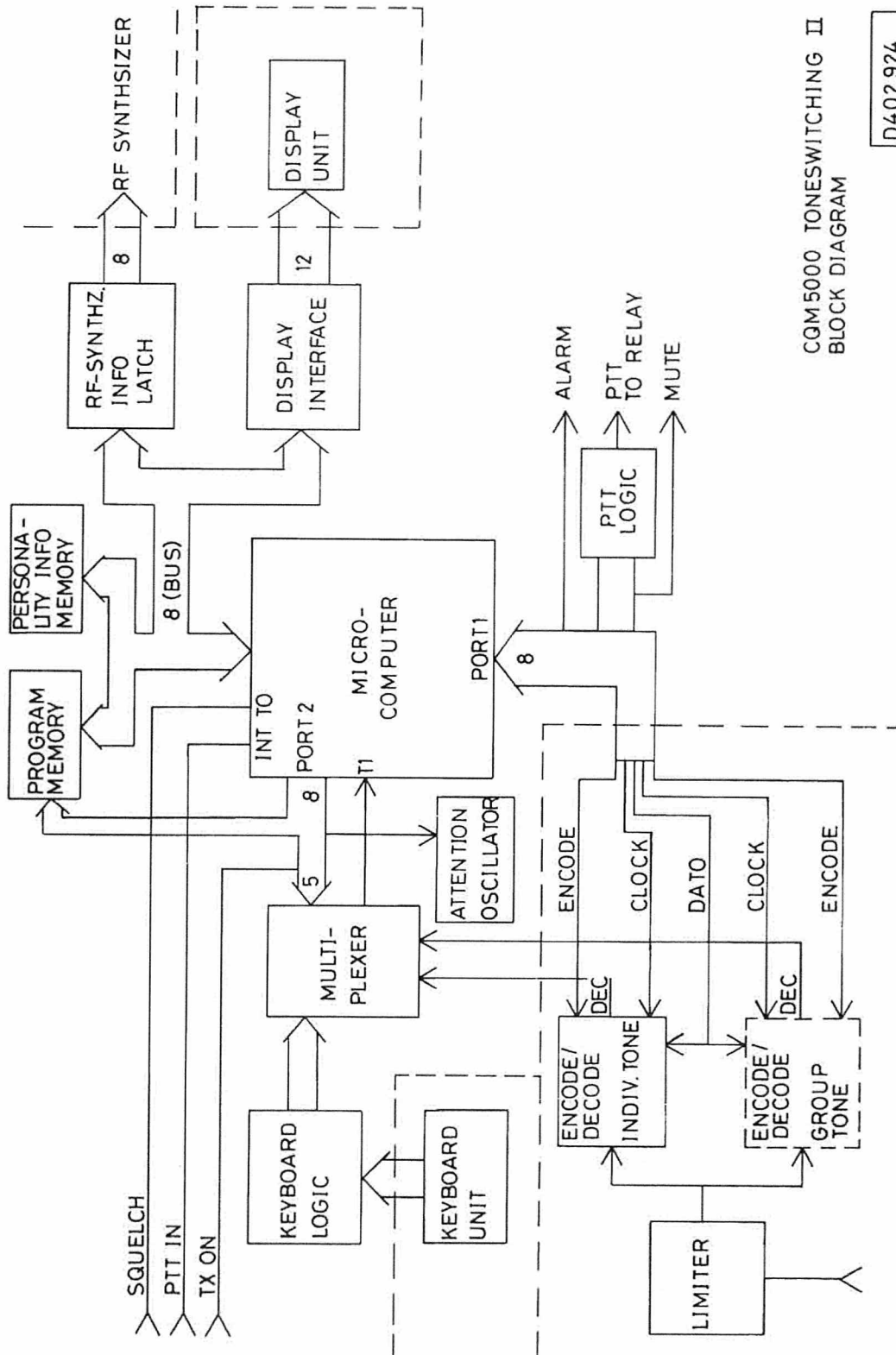

CGM5000 TONESWITCHING II
BLOCK DIAGRAM

D402.924

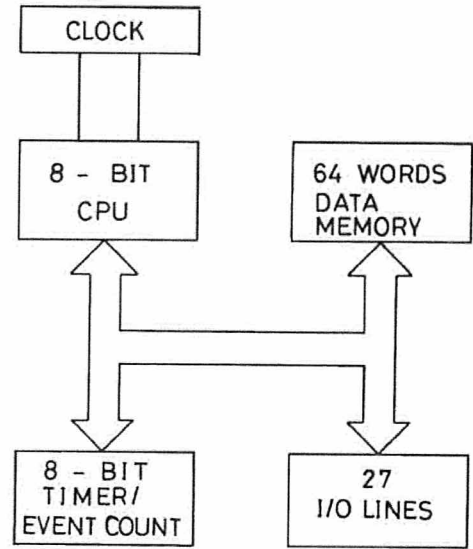
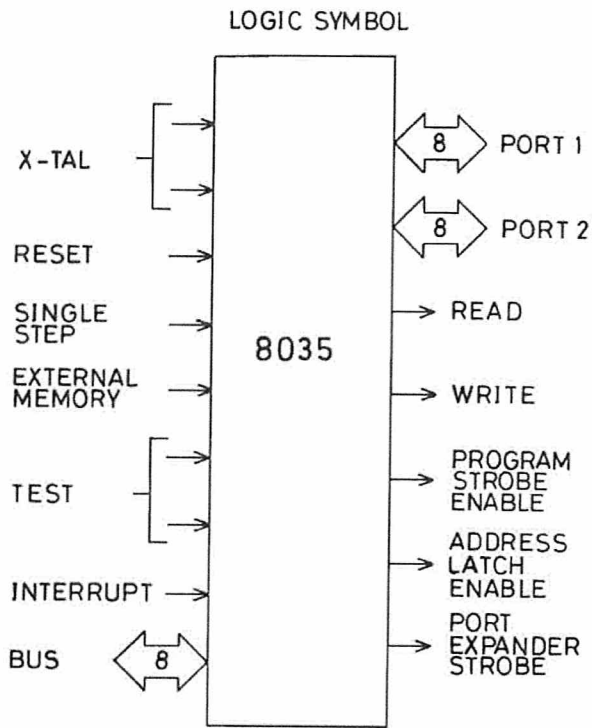

CGM5000 MICROPROCESSOR 8035
BLOCK DIAGRAM

D402.922

INSTRUCTION FETCH FROM EXTERNAL PROGRAM MEMORY

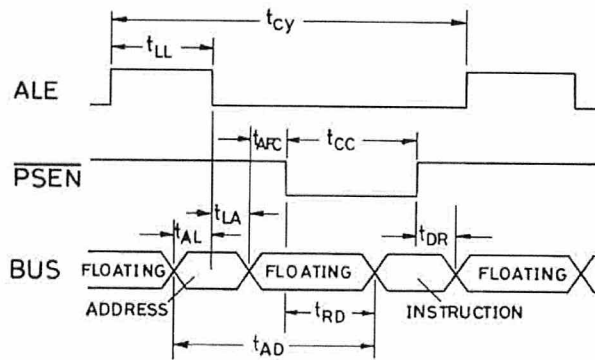

READ FROM EXTERNAL DATA MEMORY

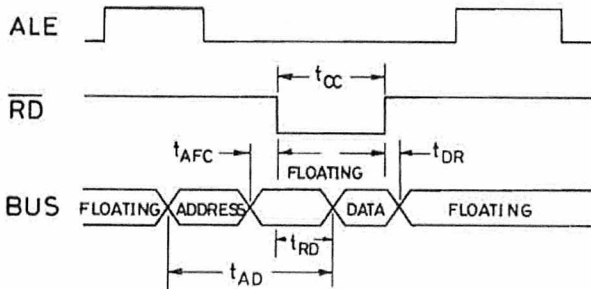

WRITE TO EXTERNAL DATA MEMORY

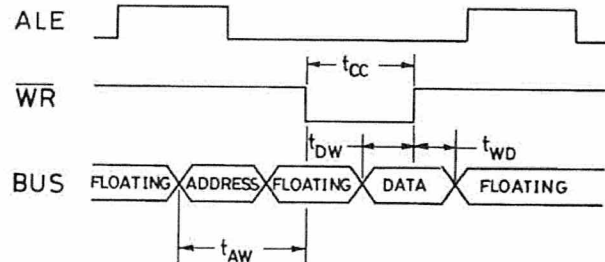

DATA FLOW CL5001

D403.005

Data memory operation

The personality PROM U804, the seven-segment decoder U808 and the two quad latches U806 and U807 act in the microcomputer system as external data memories and are therefore addressable via the databus by using the read or write pulses. Pin 8, RD, output of the read pulse and pin 10, WR, output of the write pulse are active LOW. These pulses clock or enable inputs to the integrated circuits.

The data memory operation takes place as follows:

- The wanted address which is controlled by the program is placed on the common 8 bits bus.
- ALE indicates that the address is valid and as explained in the precedent section, just when ALE goes LOW, the address is stored at the output of U803.

- The WR pulse is used to enable U806/7, U808 and U809 which are processing the data output.
To enable U806/U807 the WR pulse is not enough. They are enabled only when the WR pulse is combined with a pulse coming through the address lead A7.
- The RD pulse (read pulse) enables the personality PROM U804. Input data from U804 are valid when the RD pulse is LOW.
- The 8 bit common bus transfers all in or out data to the microcomputer.
- When the operator writes, on the keyboard, to the display, the address is available at U809 input and waits for a write pulse to be clocked in. Just when WR goes LOW, the information is clocked in and just when WR goes HIGH the data is stored.

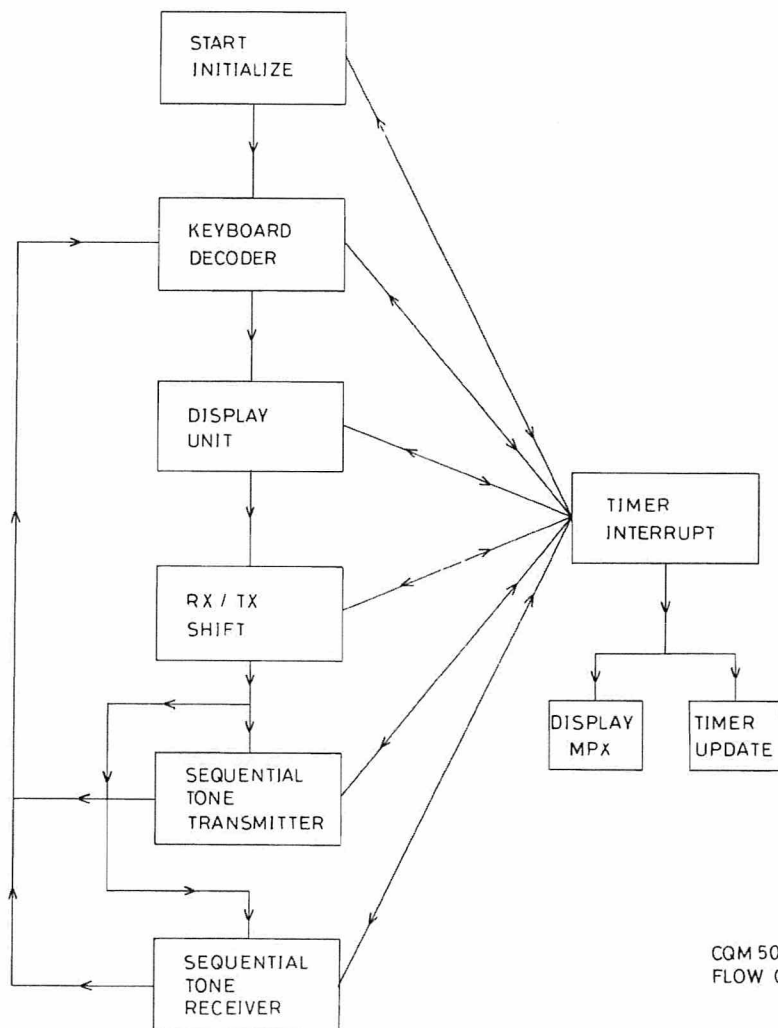

CQM 5000 TONE SWITCHING II
FLOW CHART

D402 923

Reset

If the voltage supply falls more than 10% below the 5 volt nominal, transistors Q819 and Q820 ensure a proper reset of the microcomputer system.

The transistor array U810 inverts each output from U806/U807 and supplies sharp logic outputs.

PERSONALITY PROM U804

The personality PROM contains the customer specified data of the system's functional behaviour and information about tones and channels being used in the equipment. Data informations stored in the PROM are clocked out by the RD pulse and transferred to microcomputer U801 through the common bus.

DECODER AND DETECTOR U805

The decoding circuit is able to decode a 4 x 4 matrix keyboard. The decoder output is fed into the detector (dataselector) U805 at inputs 1-6. The decoded outputs are 6 binary coded lines. The microcomputer scans the 6 lines through inputs A, B and C and read the information through U805 output z (pin 14).

LATCHES FOR RF SYNTHESIZER

The channel information sent to the RF-synthesizer via the 8 bit bus is stored in the two quad latches U806 and U807 by the write pulse.

This information is then decoded in order to make the microcomputer determine the function of the key being depressed.

The two remaining input lines 7 and 9 of U805 are used as detect inputs from the individual and group tone receiver; they are directly connected to TQ5007/5008 through connector P801. The microcomputer scans these inputs too to be able to set up the next tone to be received.

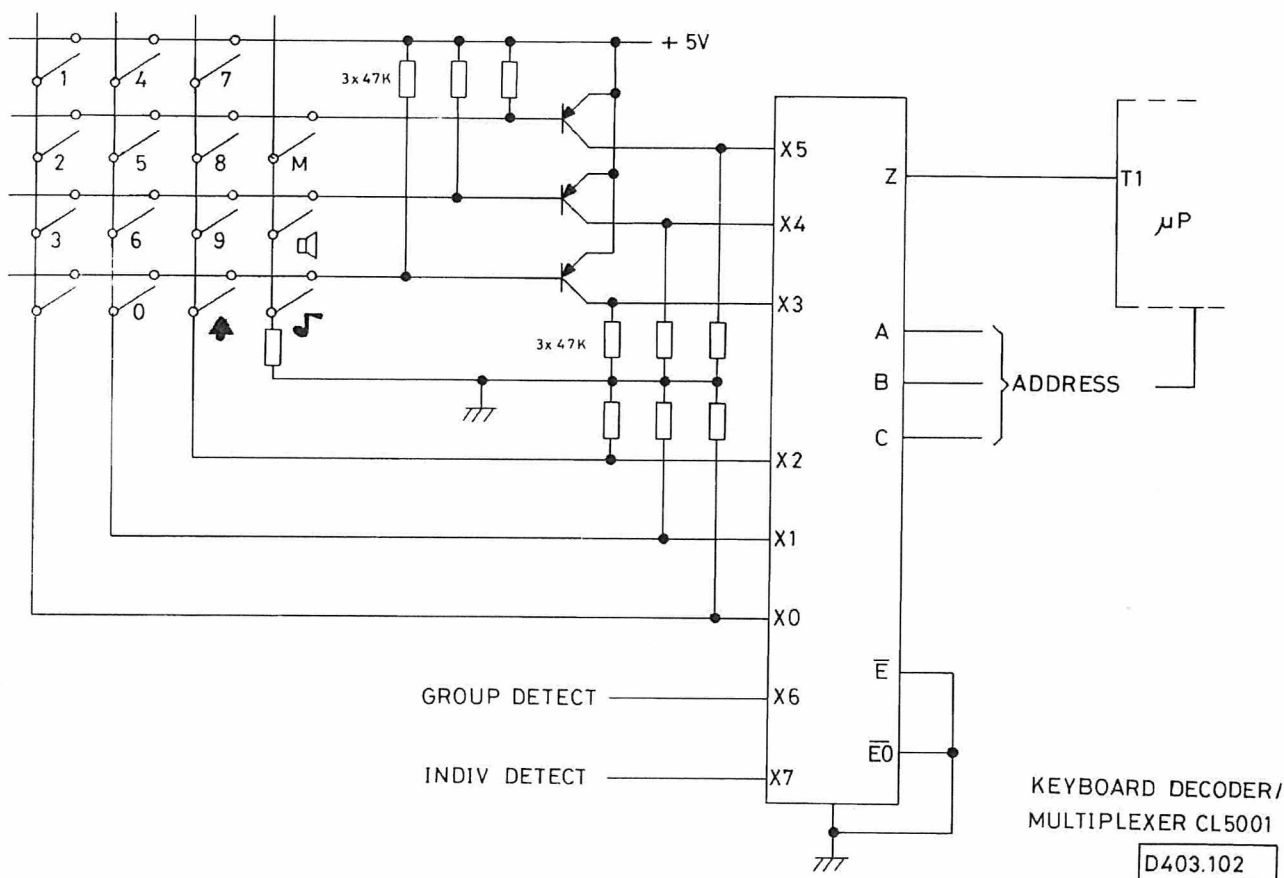

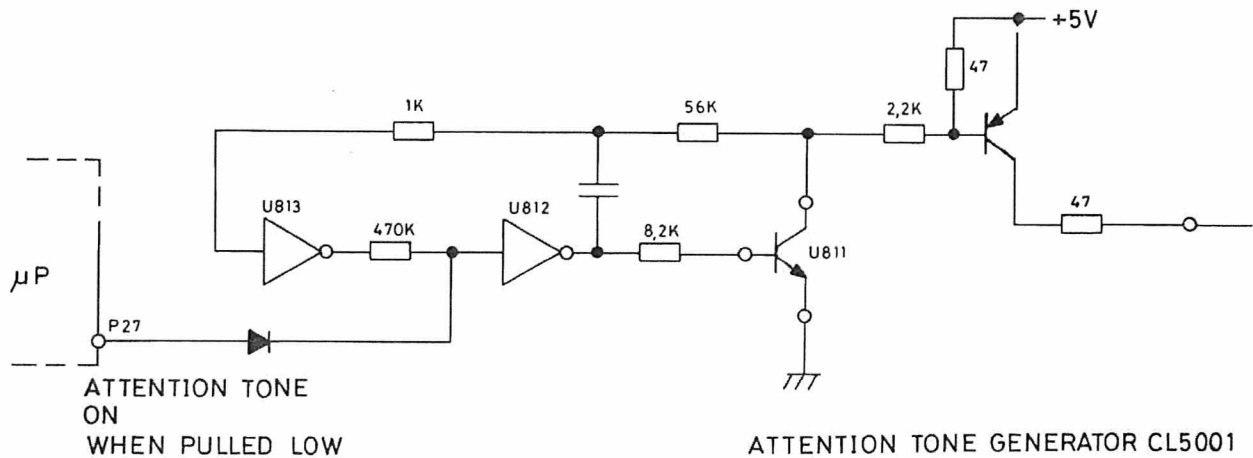

ATTENTION TONE GENERATOR CL5001

D403.103

ATTENTION OSCILLATOR U812

Attention oscillator U812 generates an acoustic feed-back from the loudspeaker when a push button is depressed.

The microcomputer controls U812 through P27, and when diode D801 goes off, U812 starts working. The oscillator circuit includes: the two inverters of U812, capacitor C808 and one transistor of the transistor array U811 (input B7-output C7). The generated signal passes through transistor Q818 and is sent via the connector P830 of the XS/FS board to the loudspeaker.

CONTROL INPUTS FROM RF5000

- Correspondance between the CL5001 and the RF board takes place through connector P806.
- The push-to-talk (PTT) function is directly connected to the interrupt pin (INT-pin 6) of the microcomputer and isolated from the PTT to relay by Q802. This transistor is controlled by the microcomputer output P10 (pin 27).
- The external tone-key function is transferred from connector P806 to keyboard decoder through the same lead as TONE-KEY button.
- RX-mute function is transferred through Q803 and one transistor in the transistor array U811 to the squelch detect input on the microcomputer TO (pin 1).

- 8,5 V TX passes through the voltage divider R803/R804 before entering the microcomputer at input P24 (pin 35).
- The VOL/SQ HI signal is transferred from the RF board through connector P806, pin 10, to the tone board TQ5007/5008 through connector P801, pin 9.

CONTROL OUTPUTS TO RF5000

- The RX mute depends on the transistor Q803 which is controlled by the output P10 (pin 27) of the microcomputer through an inverter.
- The mute output is controlled by the same output P10 (pin 27) through one of the transistors in the transistor array U811.
- The PTT signal from the RF board (pin 3 on connector P806) is directly transferred to the PTT-to-Relay output (pin 2 connector P806) when the transistor Q802 is on. The PTT to Relay is also controlled by the microcomputer output P11 through an inverter and a transistor in U811.
- The output P11 (pin 28) of the microcomputer enables the MIC BLOCK function through one of the array transistors in U811 and transistor Q801 when the PTT to relay is activated by the same port.

- The output P12 (pin 29) of the microcomputer controls the external alarm function pin 12 on P806 through an inverter and one of the array transistors in U811.
- The tone output is transferred from the tone board TQ5007/5008 through connector P801, pin 10, to the RF board through connector P806, Pin 11.

CONTROL OUTPUTS TO TQ5007/5008.

- Correspondance between the CL board and the tone board takes place through connector P801.
- The system clock, which is the sample frequency for the DTD chip, is output from counter U814 at pin 2 on connector P801. The counter U814 divides the microcomputers clock frequency (3.579545 MHz) by 16 to give 223.72 KHz. This counter is controlled by the keyboard through connector P803 pin 10.
- To set up a tone, the microcomputer loads the DTD chip with 15 bits applied to P17 (pin 34). The first five bits determine the Q-value while the last ten bits program the tone frequency either to be received or to be transmitted by the TQ unit. The data are transferred at pin 1 on P801.
- In order to load the programming bits, the microcomputer generates a data clock for each DTD chips (A101 and A102 if TQ5008) at P16 (pin 32) for A101 (indiv. call) and P14 (pin 31) for A102 (gr./all call). The data clock is sent to the chips cyncronously with the data bits at pin 5 and 6 on connector P801.
- To start and stop the tone transmission, the microcomputer controls the tone output from the TQ by two enable pins P15 (pin 32 for INDV.) and P13 (pin 30 for GR/ALL.), one for each DTD-chip.
- The detect output of each DTD-chip (pin 11 and 12 on P801) is connected to the microcomputer input T1 (pin 39) through the data selector U805.

DISPLAY INTERFACE, DIMMER AND LS-LED

- The display is a 4-digit multiplexed display. Correspondance between the CL board and the display takes place through connector P802. Pins 1 to 4 transfer information about the number to be displayed, pins 5 to 11 transfer information about which digit is going to be written.
- The microcomputer sends digit information, colon and call indicator instructions to the HEX latch U809 through the address latch U803. The write pulse from the microcomputer clocks the data in. Outputs Q0 to Q3 (pin 2, 5, 7 and 10) of U809 control 4 transistors Q807, 808, 809 and 810 whose collectors are connected to connector P802 (pin 1, 2, 3 and 4) and their emitters in series with the dimmer circuit.
- In order to turn on some or all the seven segments of one of the digits, the microcomputer places 4 bits on the common bus. The write pulse clocks them into the BCD-to-7 Segment latch decoder-drivers where they are stored, and decoded. The drivers seven outputs are connected to pin 5 - 11 on connector P802.
- The dimmer circuit consists of three transistors in cascade Q815, Q816, Q817 shunted with two diodes, and connected in series with the display driver transistors. When the photo transistor Q817 is subjected to strong light, transistor Q815 conducts and allows maximum current to pass through the display drivers. With weak light the transistor Q815 is cut-off and the diodes give a $2 \times 0,7$ volts drop in the voltage supply to the display, which then is dimmed.

VOLTAGE REGULATORS

The CL5001 is supplied by 13.6 volt nominal switched by the series transistors Q814 and Q813 which are controlled by 8.5 V cont. The 5 volt regulator U815 receives 13.6 V and supplies the entire CL and TQ board.

The other 5 volt regulator U813 ensures a continuous 5 volt supply for the data RAM in the microcomputer and gives the system a constant memory.

To interface the FS5000, 8.5 V. cont. is used to pull up the output level.

TECHNICAL SPECIFICATIONS

Voltage supply

13.6 V nom.

8.5 V regulated, continuous

Generated on CL5001

5.0 V regulated, switched

5.0 V regulated, continuous

Current consumption

420 mA +/-50 mA

max 30 mA standby, (data RAM)

Logic levels

LOW: max 0.8 V

HIGH: min 2.4 V

Squelch detect input

LOW: max 0.6 V

HIGH: min 6.5 V

Synthesizer output

LOW: max 0.3 V

HIGH: min 7.5 V

Microcomputer clock frequency

3.579545 MHz: Crystal controlled

Sample clock for TQ-unit

223.72 KHz, (Crystal/16)

Weight

150 g

Dimensions

(b x d x h) 150 x 160 x 10 mm

Temperature range (ambient)

-30°C to +60°C

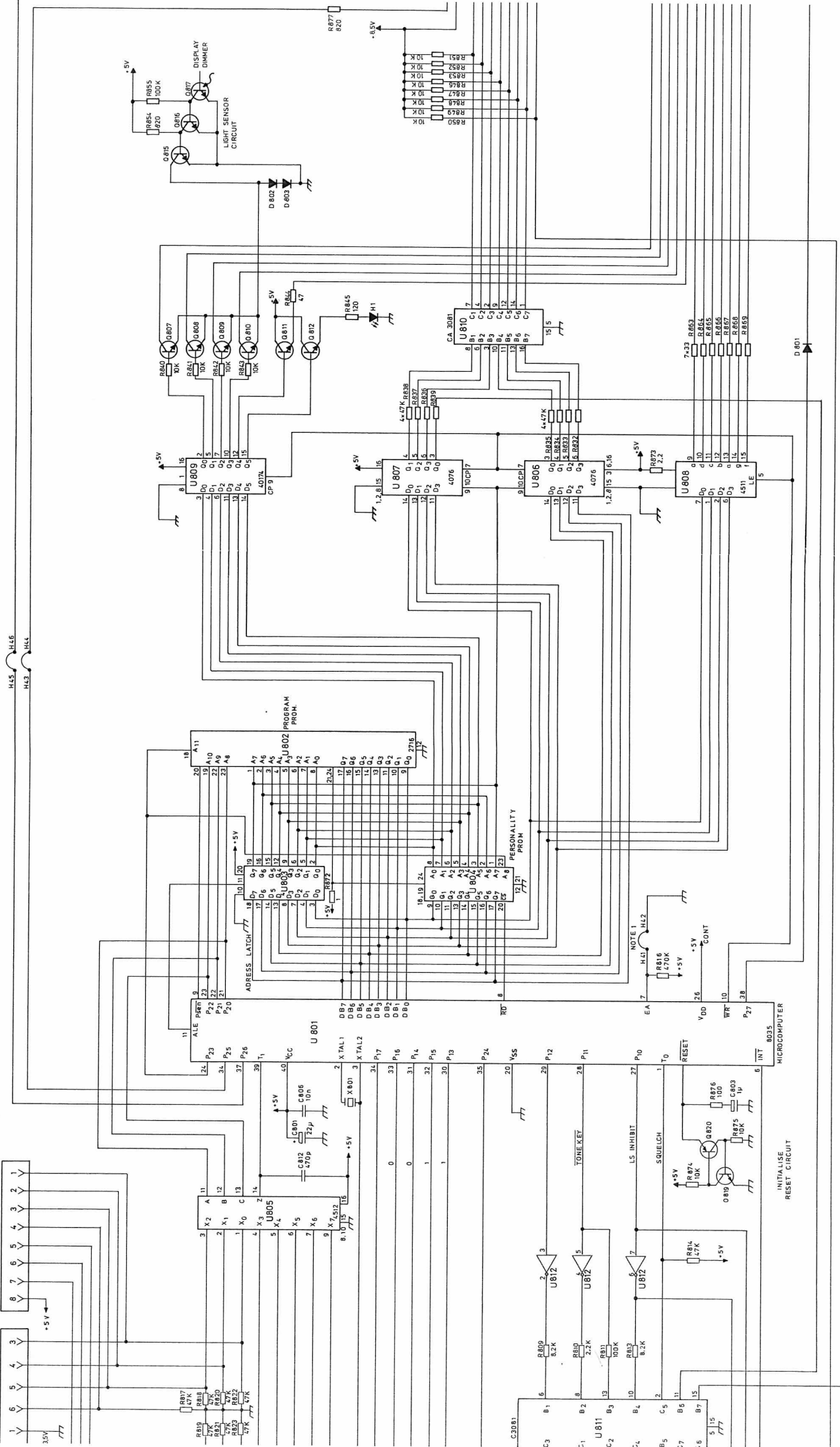

NOTE: OMIT STRAP FOR E PROM
INSERT STRAP FOR INTERNAL PROGRAM MEMORY

Storno

Storno

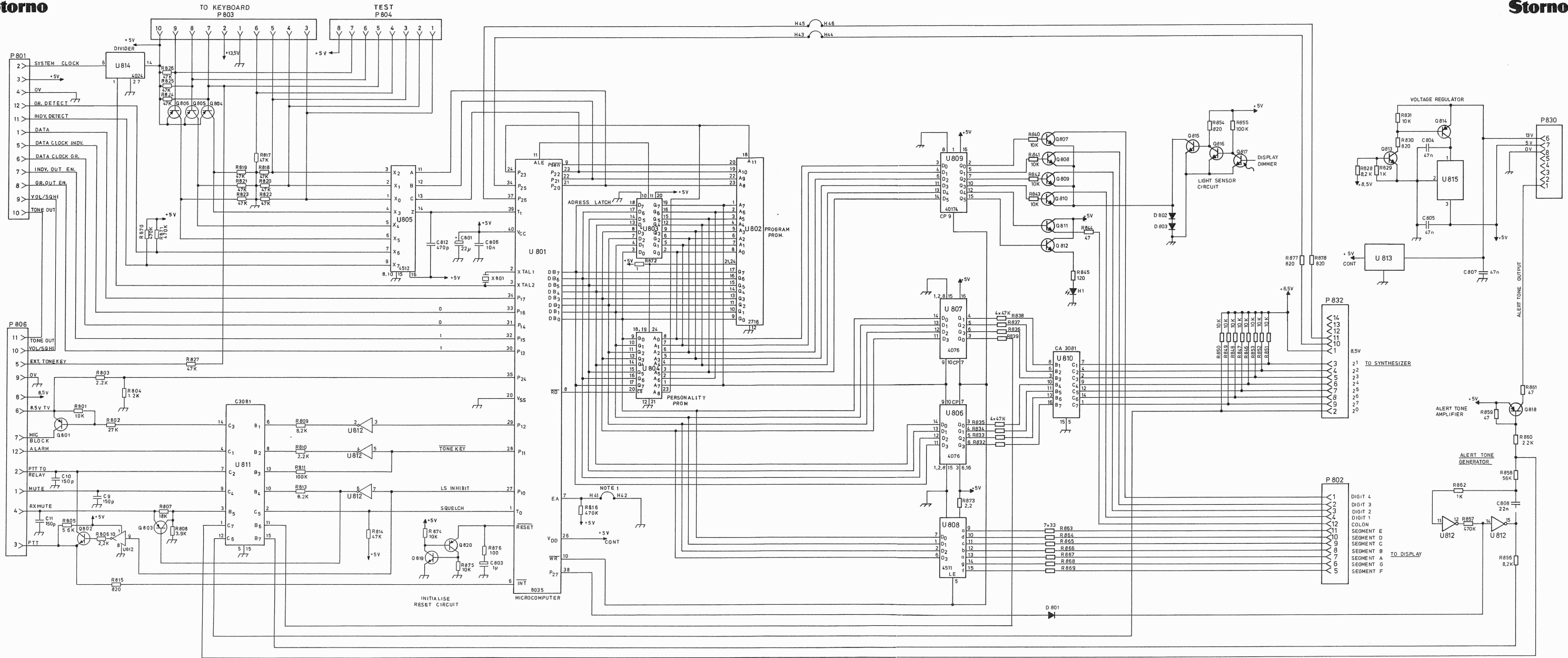

NOTE1 OMIT STRAP FOR E PROM
 INSERT STRAP FOR INTERNAL PROGRAM MEMORY

CONTROL LOGIC CL5001

D 403.011/3

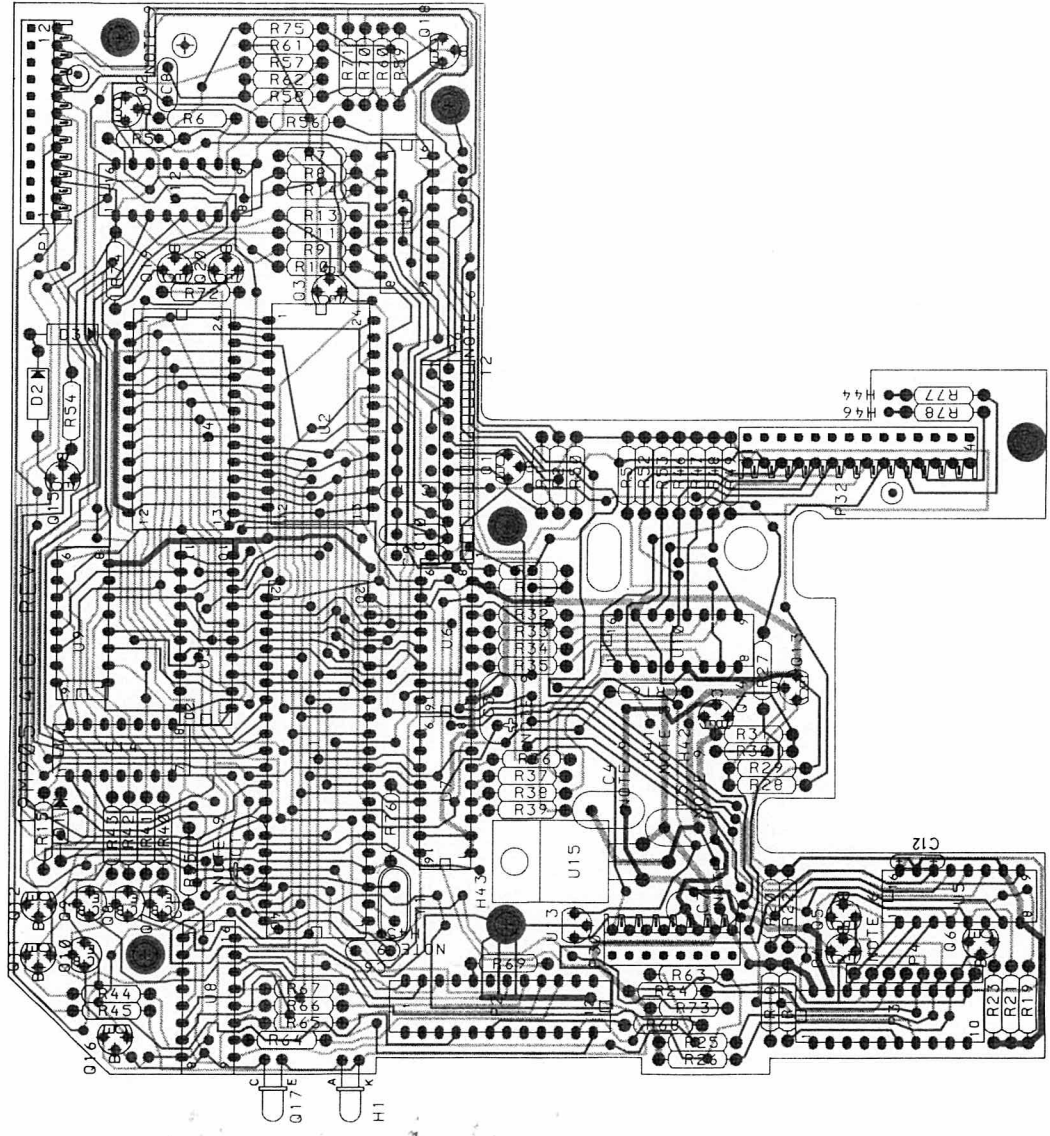

CONTROL LOGIC CL5001

D 403.039/2

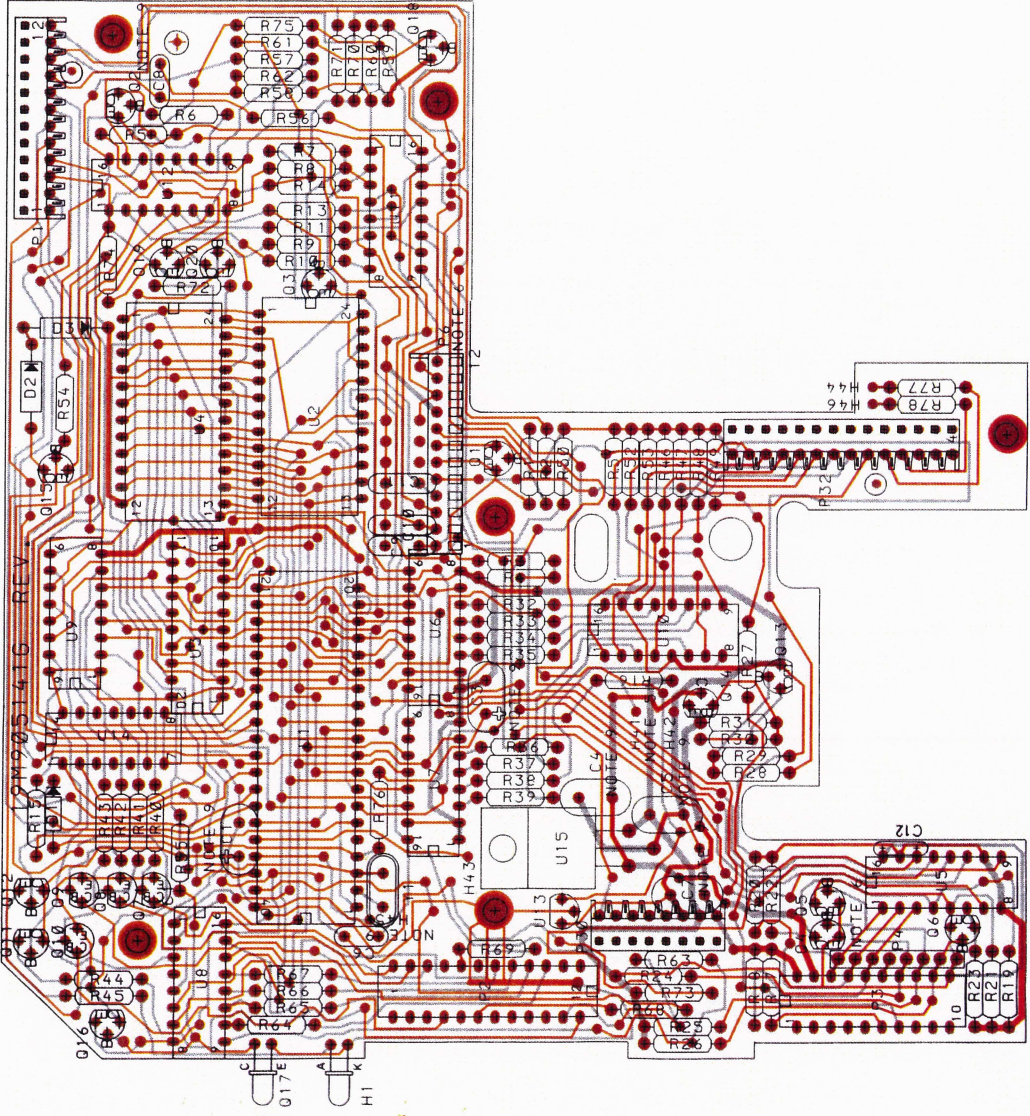

Nº	CODE	DATA
C801	19J706339P8	22 uF Elco
C803	19A701352P7	1 uF Elco
C804	19A700005P11	47 NF Polyester 50 V
C805	19A700005P11	47 NF Polyester 50 V
C806	19A700005P7	47 NF Polyester 50 V
C807	19A700005P11	47 NF Polyester 50 V
C808	19A700005P9	22 NF Polyester 50 V
C809	19A700233P27	150 pF Ceramic
C810	19A700233P27	150 pF Ceramic
C811	19A700233P27	150 pF Ceramic
C812	19A700233P27	150 pF Ceramic
C813	19A700233P27	150 pF Ceramic
C814	19A700233P27	150 pF Ceramic
C815	19A700233P27	150 pF Ceramic
C816	19A700233P27	150 pF Ceramic
D801	19A700028P1	1N4148 Diode
D802	19J706100P1	1N4004 Diode
D803	19J706493P2	1N4004 Diode
H1	19J706493P2	LED/YW
P801	19A700041P11	Connector, Fem.
P802	19J706143P4	Connector, Fem.
P803	19J706143P2	Connector, Fem.
P804	19J706215P8	Connector, Male, Test
P806	19A700041P61	Connector, Fem.
P830	19A700041P7	Connector, Fem.
P832	19A700041P13	Connector, Fem.
Q801	19A700020P1	BC308 Transistor
Q802	19A700017P1	BC238 Transistor
Q803	19A700020P1	BC308 Transistor
Q804	19A700020P1	BC308 Transistor
Q805	19A700020P1	BC308 Transistor
Q806	19A700020P1	BC308 Transistor
Q807	19J706133P1	MPSA13 Transistor
Q808	19J706133P1	MPSA13 Transistor
Q809	19J706133P1	MPSA13 Transistor
Q810	19J706133P1	MPSA13 Transistor
Q811	19A700017P1	BC238 Transistor
Q812	19A700017P1	BC238 Transistor
Q813	19A700017P1	BC238 Transistor
Q814	19A700026P1	BC369 Transistor
Q815	19A700017P1	BC238 Transistor
Q816	19A700017P1	BC238 Transistor
Q817	19J706036P1	BP103B111 Transistor, Photo
Q818	19A700020P1	BC308 Transistor
Q819	19A700017P1	BC238 Transistor
Q820	19A700020P1	BC308 Transistor
R801	19A700019P49	10 Kohm Resistor 0.25 W

Nº	CODE	DATA
R802	19A700019P54	27 Kohm Resistor 0.25 W
R803	19A700019P41	2.2 Kohm Resistor 0.25 W
R804	19A700019P38	1.2 Kohm Resistor 0.25 W
R805	19A700019P46	5.6 Kohm Resistor 0.25 W
R806	19A700019P41	2.2 Kohm Resistor 0.25 W
R807	19A700019P52	18 Kohm Resistor 0.25 W
R808	19A700019P44	3.9 Kohm Resistor 0.25 W
R809	19A700019P48	8.2 Kohm Resistor 0.25 W
R810	19A700019P41	2.2 Kohm Resistor 0.25 W
R811	19A700019P61	100 Kohm Resistor 0.25 W
R813	19A700019P48	8.2 Kohm Resistor 0.25 W
R814	19A700019P57	47 Kohm Resistor 0.25 W
R815	19A700019P36	820 ohm Resistor 0.25 W
R816	19A700010P69	470 Kohm Resistor 0.25 W
R817	19A700019P57	47 Kohm Resistor 0.25 W
R818	19A700019P57	47 Kohm Resistor 0.25 W
R819	19A700019P57	47 Kohm Resistor 0.25 W
R820	19A700019P57	47 Kohm Resistor 0.25 W
R821	19A700019P57	47 Kohm Resistor 0.25 W
R822	19A700019P57	47 Kohm Resistor 0.25 W
R823	19A700019P57	47 Kohm Resistor 0.25 W
R824	19A700019P57	47 Kohm Resistor 0.25 W
R825	19A700019P57	47 Kohm Resistor 0.25 W
R826	19A700019P57	47 Kohm Resistor 0.25 W
R827	19A700019P57	47 Kohm Resistor 0.25 W
R828	19A700019P48	8.2 Kohm Resistor 0.25 W
R829	19A700019P37	1 Kohm Resistor 0.25 W
R830	19A700018P40	1.8 Kohm Resistor 0.25 W
R831	19A700019P49	10 Kohm Resistor 0.25 W
R832	19A700019P57	47 Kohm Resistor 0.25 W
R833	19A700019P57	47 Kohm Resistor 0.25 W
R834	19A700019P57	47 Kohm Resistor 0.25 W
R835	19A700019P57	47 Kohm Resistor 0.25 W
R836	19A700019P57	47 Kohm Resistor 0.25 W
R837	19A700019P57	47 Kohm Resistor 0.25 W
R838	19A700019P57	47 Kohm Resistor 0.25 W
R839	19A700019P57	47 Kohm Resistor 0.25 W
R840	19A700019P49	10 Kohm Resistor 0.25 W
R841	19A700019P49	10 Kohm Resistor 0.25 W
R842	19A700019P49	10 Kohm Resistor 0.25 W
R843	19A700019P49	10 Kohm Resistor 0.25 W

CONTROL LOGIC CL5001

X403.023

Nº	CODE	DATA
R844	19A700019P21	47 ohm Resistor
R845	19A700019P26	120 ohm Resistor
R846	19A700019P49	10 Kohm Resistor
R847	19A700010P49	10 Kohm Resistor
R848	19A700010P49	10 Kohm Resistor
R849	19A700019P49	10 Kohm Resistor
R850	19A700019P49	10 Kohm Resistor
R851	19A700019P49	10 Kohm Resistor
R852	19A700019P49	10 Kohm Resistor
R853	19A700019P49	10 Kohm Resistor
R854	19A700019P36	820 ohm Resistor
R855	19A700019P61	100 Kohm Resistor
R856	19A700019P48	8.2 Kohm Resistor
R857	19A700019P69	470 Kohm Resistor
R858	19A700019P58	56 Kohm Resistor
R859	19A700019P41	2.2 Kohm Resistor
R860	19A700019P41	2.2 Kohm Resistor
R861	19A700019P21	47 ohm Resistor
R862	19A700019P37	1 Kohm Resistor
R863	19A700019P19	33 ohm Resistor
R864	19A700019P19	33 ohm Resistor
R865	19A700019P19	33 ohm Resistor
R866	19A700019P19	33 ohm Resistor
R867	19A700019P19	33 ohm Resistor
R868	19A700019P19	33 ohm Resistor
R869	19A700019P19	33 ohm Resistor
R870	19A700019P69	470 Kohm Resistor
R871	19A700019P69	470 Kohm Resistor
R872	19A700019P1	1 ohm Resistor
R873	19A700019P5	2.2 ohm Resistor
R874	19A700019P49	10 Kohm Resistor
R875	19A700019P49	10 Kohm Resistor
R876	19A700019P37	1 Kohm Resistor
R877	19A700019P36	820 ohm Resistor
R878	19A700019P36	820 ohm Resistor
U801	19J706033P1	8035 Int. circuit
U802	19J706385P1	2716 EProm, 16 K
U803	19A7000037P115	64LS373 Int. Circuit
U804	19A700117P1	512 x 8 Prom
U805	19A700029P205	HEF4512 Int. Circuit
U806	19A700029P59	HEF4076 Int. Circuit
U807	19A700029P59	HEF4076 Int. Circuit
U808	19A700029P204	HEF4511 Int. Circuit
U809	19A700029P53	HEF40174 Int. Circuit
U810	19A706383P1	CA3081 Int. Circuit
U811	19J706383P1	CA3081 Int. Circuit
U812	19A700176P1	HEF4049 Int. Circuit

Nº	CODE	DATA
U813	19J706031P1	78L05 Int. Circuit
U814	19A700029P18	HEF4024 Int. Circuit
U815	19J706032P1	MC7805 Int. Circuit
X801	19J706331P6	Socket
X802	19J706331P8	Socket
X803	19J706331P8	Socket
Y801	19J706635P1	Crystal

40 pos
24 pos
24 pos
3. 579545 MHz

CONTROL LOGIC CL5001

X403.023

CQM 5000 TONESWITCHING II

OPERATOR CONTROLS AND INDICATORS

GENERAL

The tone switching II version is a CQM5000 set with operator - programmable 5-tone sequential equipment and, if more than 1 RF-channel is used, a frequency synthesizer.

Standard controls and indicators: (ref. fig. 1)

ON/OFF SWITCH

Controls the DC power supply to all the radio circuits except system memory, i. e. the system state remains unchanged even after power OFF and ON.

SQUELCH CANCEL SWITCH

Depressing this button will cancel the noise squelch so that the noise of an unused channel can be heard, if at the same time the tone receiver status is "LS-open".

VOLUME CONTROL

Adjusts AF amplifier output level.

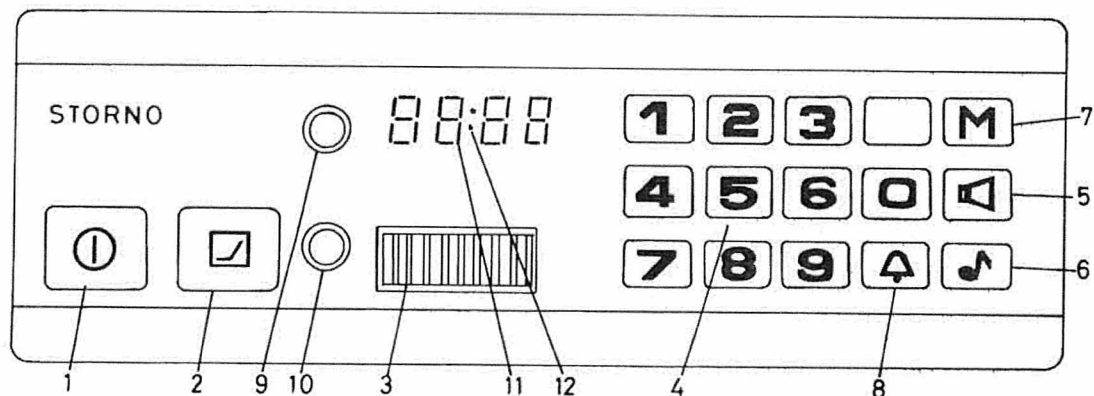

Fig. 1.

- | | |
|-----------------------------|---|
| 1. ON/OFF SWITCH | 7. MODE, I.E. TONE/RF CHANNEL SELECTION |
| 2. SQUELCH CANCEL SWITCH | 8. EXTERNAL ALARM SELECT |
| 3. VOLUME CONTROL | 9. LS INDICATOR - YELLOW |
| 4. NUMERICAL KEYBOARD 0 - 9 | 10. TRANSMIT INDICATOR - RED |
| 5. LS ON/OFF (MONITOR) | 11. 4 DIGIT DISPLAY, TONE-/RF- CHANNEL NUMBER |
| 6. TONE KEY | 12. COLON, BUSY/EXTERNAL ALARM - INDICATOR |

NUMERICAL KEYBOARD

Is used for entering tone-call numbers and - if more than one RF channel is available - also the RF channel number.

Whenever a key is activated a short alert tone is heard in the loudspeaker.

KEYBOARD ENTRY MODE

Depressing the "Mode"-key (7) alternately prepares the system for input of tone number or RF channel number respectively. The display (11) indicates which input mode has been selected by showing a "0" followed by a blank as the two leftmost positions in the RF-channel input mode, whereas a leading zero followed by a blank will never exist when a tone call number is displayed.

LS ON/OFF

Depressing the LS ON/OFF key will normally alternately open respectively close the tone receiver's AF-gate i. e. switch the LS ON and OFF.

This key will not be able to open the AF channel if the "Privacy" option is selected.

TONE KEY

Pressing the tone key will cause the RF-transmitter to be keyed and remain so while the tone transmit telegram is transmitted - except in a situation where the RF channel is occupied and the LS is closed. Attempt to press the tone key in this situation will only produce a warning signal in the loudspeaker. Upon the termination of the transmission, the LS will be opened.

"MODE"

Select keyboard entry mode - see clause 4.

EXTERNAL ALARM SELECT

Pressing the External Alarm key causes an alarm transducer - if employed - to sound for approx. 1 sec. whenever a correct tone telegram has been received. The selection of this function is indicated by the display being blank except that the colon (12) is lit.

Pressing the key again makes the system return to the previous state i. e. disables the alarm and lights the display.

LS INDICATOR

Is a yellow LED which, when lit, indicates that the AF gate of the tone receiver is open (LS is ON).

The LED can either flash or show constant light.

Flashing light indicates that a call has been received, but not yet answered.

When a call is answered - either by tonekeying or normal keying of the transmitter, the LED changes to constant light.

The LED will also show constant light when the operator has opened the LS manually, i. e. by means of the LS ON/OFF key (5).

TRANSMIT INDICATOR

Is a red LED, indicating that the RF transmitter is on.

4 DIGIT DISPLAY

Indicates which RF frequency channel number and tonecall number has been entered by the operator.

See clauses 4 and 8 for explanation of display modes.

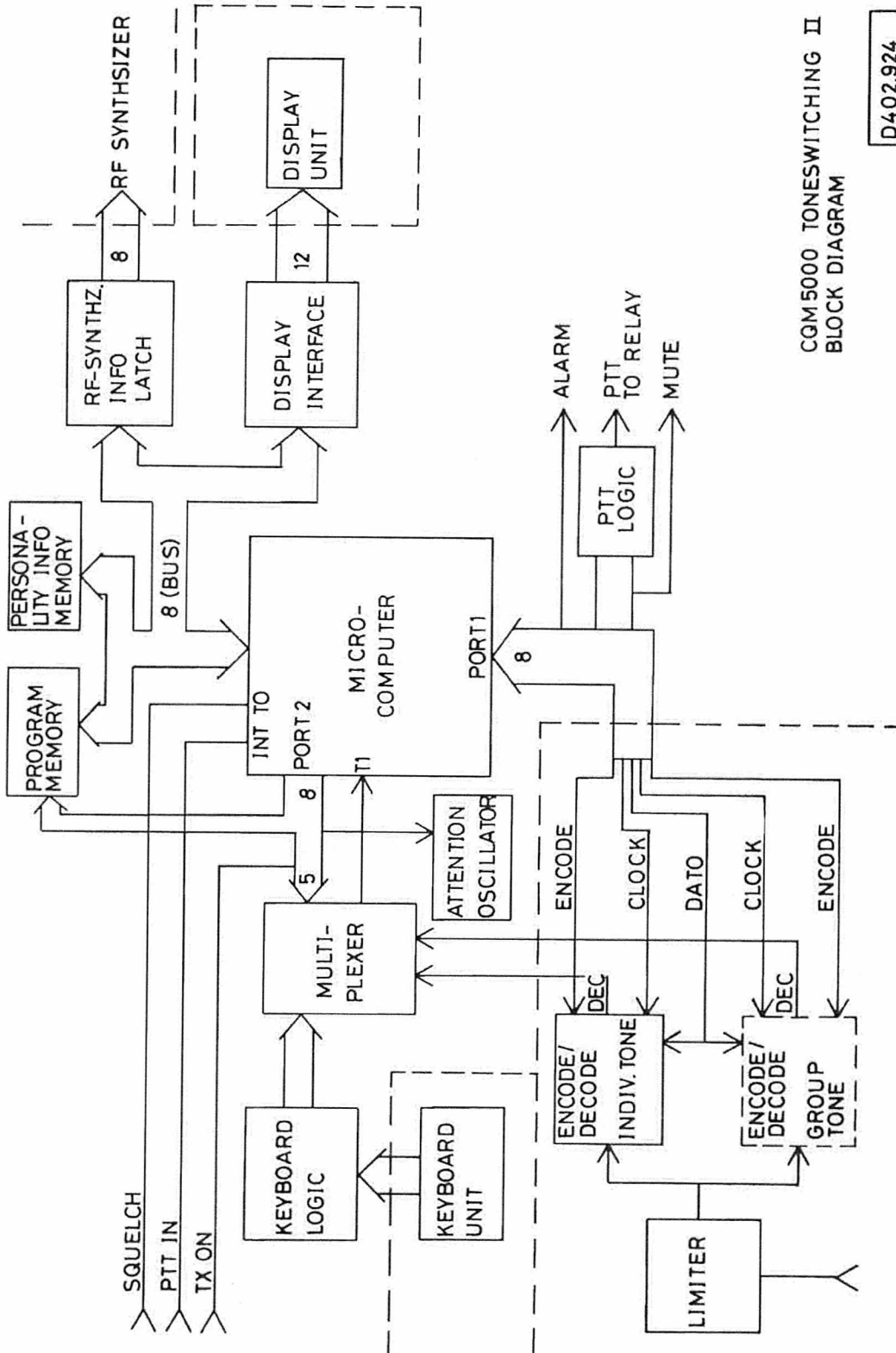

QGM5000 TONESWITCHING II
BLOCK DIAGRAM

D402.924

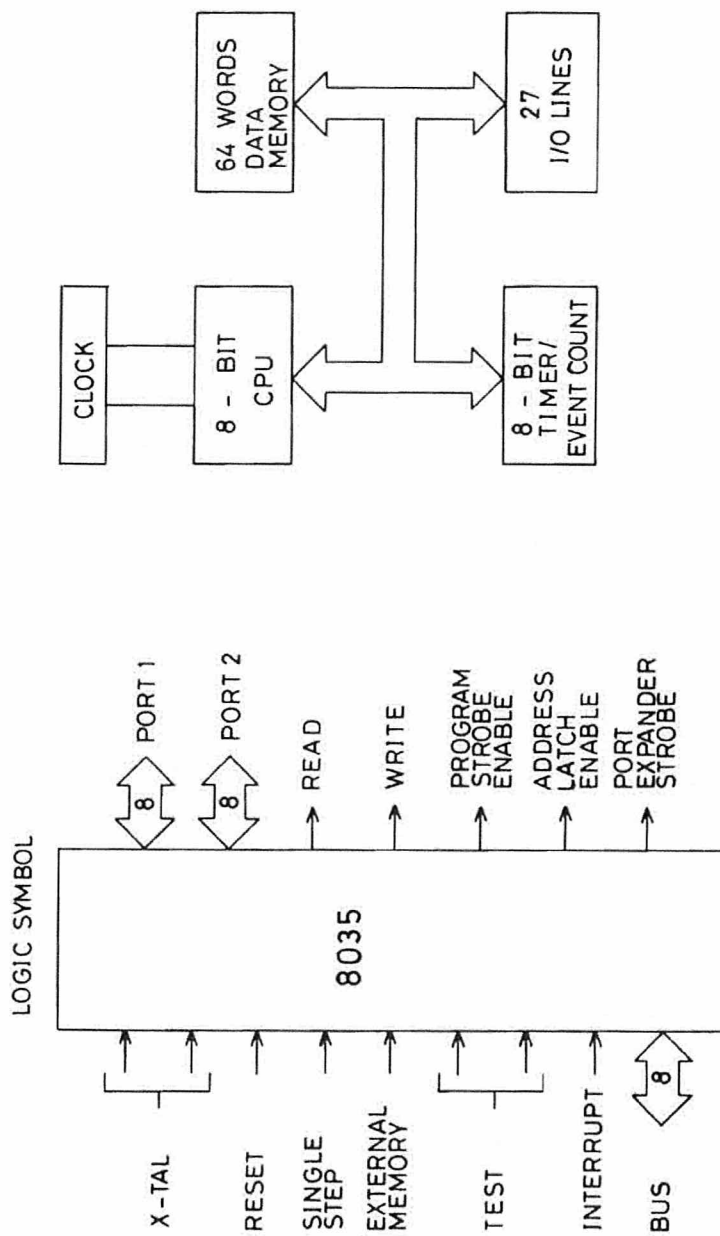

CQM5000 MICROPROCESSOR 8035
BLOCK DIAGRAM

D402.922

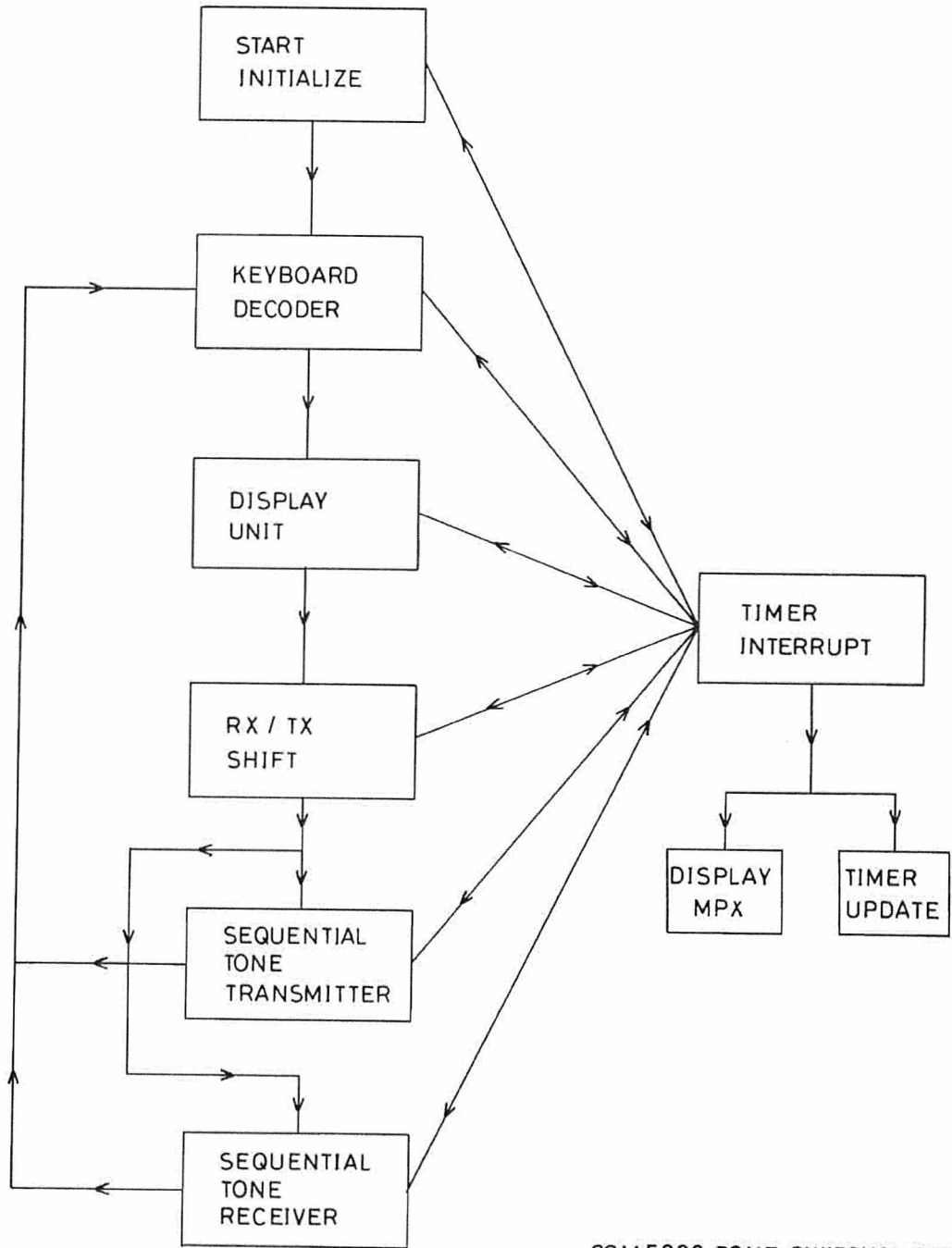

CQM 5000 TONE SWITCHING II
FLOW CHART

D402.923

COLON

Is used as a squelch indicator - also called "busy lamp".

This means that the colon will flash whenever the receiver RF-channel is occupied i.e. when the channel is busy.

As explained in clause 8, a lit colon in an otherwise blank display indicates that external alarm has been selected.

Four independent telegrams can be specified

1st tone transmit	<input type="text"/>	1
2nd tone transmit	<input type="text"/>	2
acknowledgement/3rd tone transmit	<input type="text"/>	3
tone receiver	<input type="text"/>	4

Options within each of the 4 telegrams

0 - 7 tones

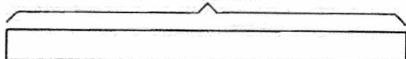

- Prolonged 1st tone
- Transmit telegram twice
or
- Transmit next telegram after this one
- Specify which tone-number for each position
or
- Specify as operator selectable (max. 4 total) - can be up to 7, but only the 4 last entries are shown on the display.

Tone system

- ZVEI or CCIR tone tables can be specified - including misc. variants
- ZVEI or CCIR timing

Tone transmit

- Always 1st telegram
- Can be repeated
or
- Can be followed by 2nd telegram
- Programmable tones can be positioned anywhere in all sequences - 4 total; up to 7 in special cases - display will only show 4.

Acknowledge

- Transmitted automatically after reception of valid call. - after carrier has disappeared/or immediately after valid call.
- Can be any of the 4 telegrams - (repeated - or followed by next telegram)

"I.D"

- Automatic transmission of 1 (or more) telegram(s) when pushing transmit key
- while LS closed
- and channel is not busy
- Use as - ID
- status
- tone transmit

Group call receive (with TQ5008 only)

- Any tone in tone table
- At any position in tone receive - telegram
- Hierarchical Group Call/All Call
- Two types of All Call

Hierarchical group call

Hierarchical

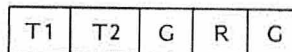

"All-Call", hierarchical

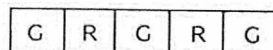

"All-Call", old fashioned

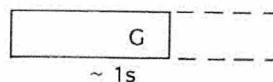

Privacy

- Operator cannot open LS manually
- Keying and tonekeying is not possible if channel is busy - (true also without Privacy if LS is closed).
- LS will close automatically 1/4s - 1 min after last transmission or reception of carrier.

RF channel control

- Up to 99 channels can be specified (RF bandwidth may limit to lower number).

INTRODUCTION TO PROGRAMMING THE PERSONALITY PROM

- The "Personality Prom" contains customer specified information on the system's functional behavior, and about tones and channels being used in the equipment.
- The Personality Prom is a 512 x 8 bits Prom.
- For Programming the Prom, Storno recommends to use "DATA I/O System 19".
- For addressing the information in the Prom 8 bits (1 byte) are used. The addressing is made in Hex code.
- The data output is 8 bits, and controlled by the selected address.
- Data is programmed into the Prom in Hex code using DATA I/O System 19.
- All binary codes shall be converted to Hex-code before programming the Prom in "DATA I/O System 19".

The Hex code

BINARY VALUE	HEX VALUE	DEC.
0000	0	0
0001	1	1
0010	2	2
0011	3	3
0100	4	4
0101	5	5
0110	6	6
0111	7	7
1000	8	8
1001	9	9
1010	A	10
1011	B	11
1100	C	12
1101	D	13
1110	E	14
1111	F	15

ex. of converting 8 bits to Hex code.

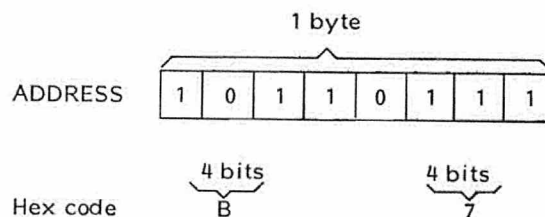

INFORMATION IN THE PERSONALITY-PROM
(U804)

ADDRESS IN HEX CODE

00	FREE
01	MODEWORD 1
02	MODEWORD 2
03	1. ST FORMAT
04	2. ST FORMAT
05	3. ST FORMAT (ACK)
06	SR FORMAT
07	TONE SYSTEM
08	12 x ZVEI/CCIR TONE CODES
13	
14	4 x 7 TONE CODE FORMATS
2F	
30	GROUP/ ALL CALL
31	ID/ACK
32	DTD (TONE SYSTEM/Q-VALUE)
33	PRIVACY
34	FREE
35	100 x RX-CODES
98	
99	100 x TX-CODES
FC	
FD	FREE
FE	FREE
FF	FREE

MODEWORD 1 ADD 01H

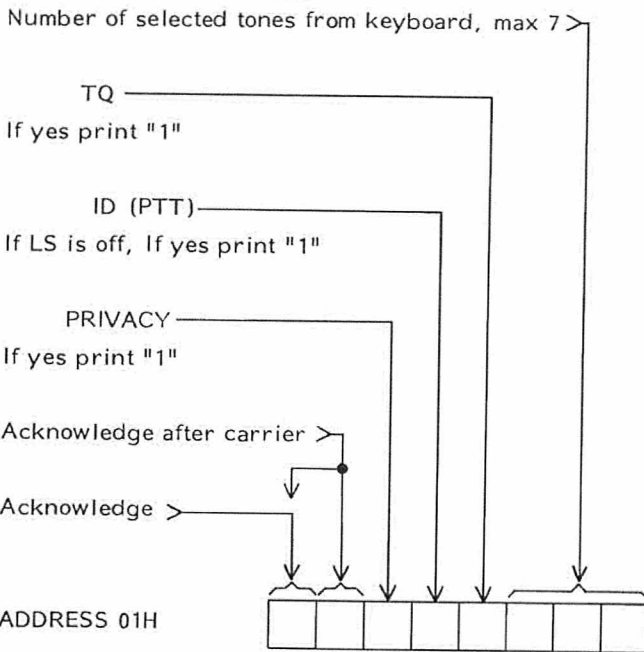

MODEWORD 2 ADD 02H

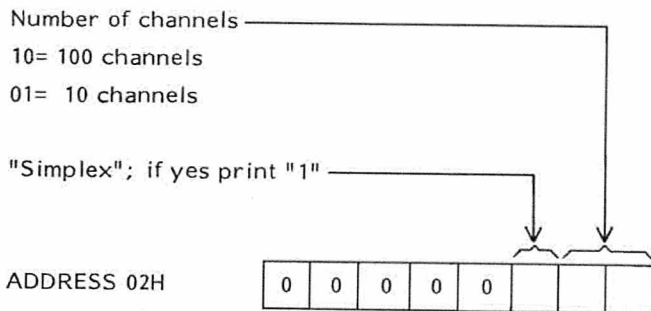

1 ST FORMAT ADD 03H

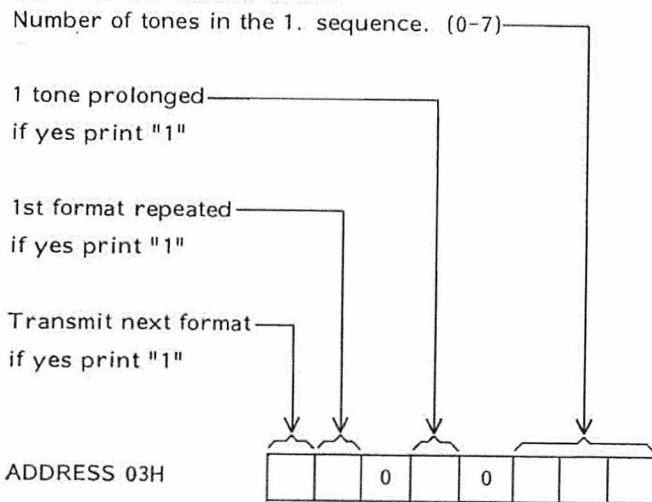

2 ST FORMAT ADD 04H

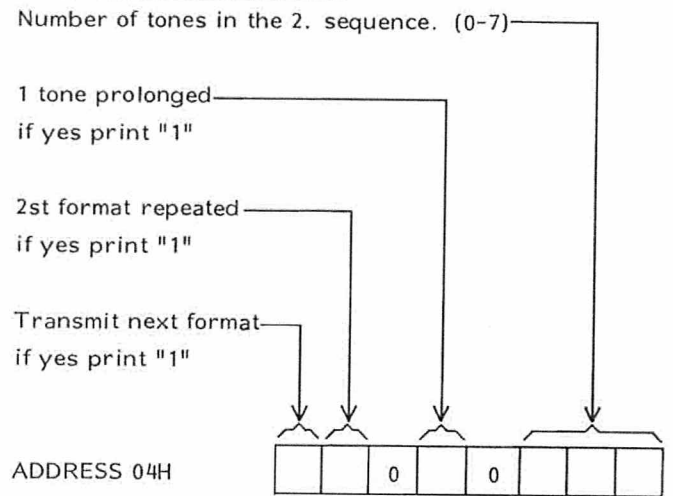

3 ST FORMAT (ACK) ADD 05H

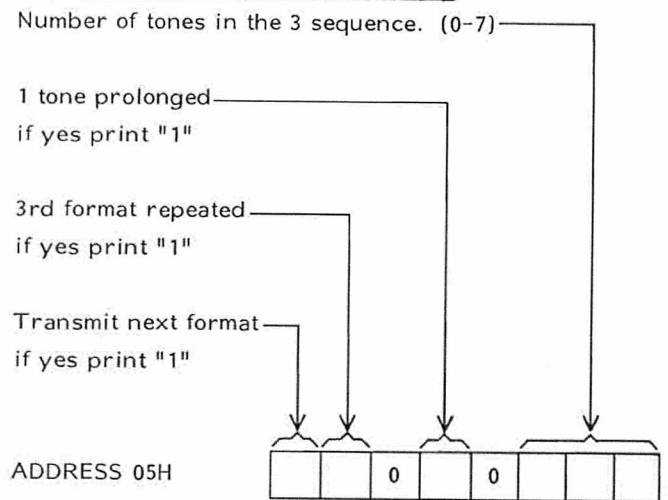

SR FORMAT ADD 06H

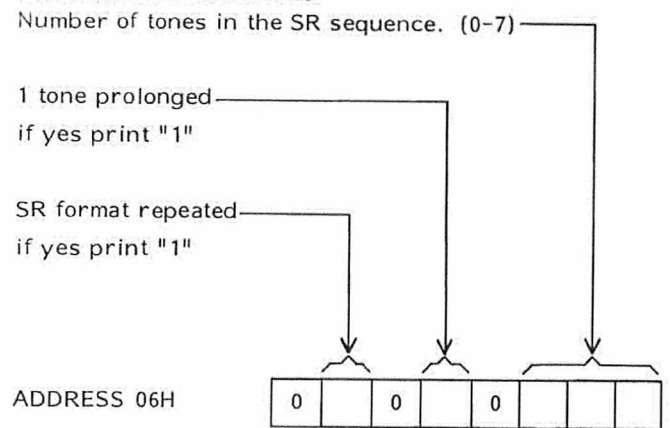

TONE SYSTEM ADD 07H

Which tone system is going to be used

If tone system =ZVEI (STORNO)

Then 07H
in address 07H

0	0	0	0	0	1	1	1
---	---	---	---	---	---	---	---

Tone system =CCIR

Then 0AH
in address 07H

0	0	0	0	1	0	1	0
---	---	---	---	---	---	---	---

Tone system = EEA (OPTION)

Then 04H
in address 07H

0	0	0	0	0	1	0	0
---	---	---	---	---	---	---	---

12 x ZVEI/CCIR TONE CODES ADDRESS 08H - 13H

Address in PROM	Frequency in binary code								Hz	Hex code	Internal tone index	Digit																									
08	1	0	1	1	0	0	0	0	2400	B0	00	0																									
09	0	1	0	0	1	1	1	0	1060	4E	01	1																									
0A	0	1	0	1	0	1	0	1	1160	55	02	2																									
0B	0	1	0	1	1	1	0	1	1270	5D	03	3																									
0C	0	1	1	0	0	1	1	1	1400	67	04	4																									
ZVEI I Frequency 0D	0	1	1	1	0	0	0	0	1530	70	05	5																									
0E	0	1	1	1	1	0	1	0	1670	7A	06	6																									
0F	1	0	0	0	0	1	1	0	1830	86	07	7																									
10	1	0	0	1	0	0	1	0	2000	92	08	8																									
11	1	0	1	0	0	0	0	1	2200	A1	09	9																									
Note 1 Note 2 12	1	0	1	1	1	1	1	0	2600	BE	0A	Repeat																									
13	1	1	0	0	1	1	0	1	2800	CD	0B	Alarm																									
ZVEI II Note 1: Note 2:	<table border="1" style="width: 100%; border-collapse: collapse;"> <tr> <td style="width: 12.5%;">12</td> <td>0</td><td>1</td><td>0</td><td>0</td><td>0</td><td>1</td><td>1</td><td>1</td> <td>970</td> <td>47</td> <td>0A</td> <td></td> </tr> <tr> <td>13</td> <td>0</td><td>1</td><td>0</td><td>0</td><td>0</td><td>0</td><td>0</td><td>1</td> <td>885</td> <td>41</td> <td>0B</td> <td></td> </tr> </table>								12	0	1	0	0	0	1	1	1	970	47	0A		13	0	1	0	0	0	0	0	1	885	41	0B				
12	0	1	0	0	0	1	1	1	970	47	0A																										
13	0	1	0	0	0	0	0	1	885	41	0B																										

To be programmed into the PROM
from ADD. 08H- 13H.

12 x ZVEI/CCIR TONE CODES ADDRESS 08H - 13H

Address in PROM	Frequency in binary code								Hz	Hex code	Internal tone index	Digit
	08	09	0A	0B	0C	0D	0E	0F				
	1	0	0	1	0	0	0	1	1981	91	00	0
	0	1	0	1	0	0	1	0	1124	52	01	1
	0	1	0	1	1	0	0	0	1197	58	02	2
	0	1	0	1	1	1	0	1	1275	5D	03	3
	0	1	1	0	0	0	1	1	1358	63	04	4
CCIR	0	1	1	0	1	0	1	0	1446	6A	05	5
	0	1	1	1	0	0	0	1	1540	71	06	6
	0	1	1	1	1	0	0	0	1640	78	07	7
	1	0	0	0	0	0	0	0	1747	80	08	8
	1	0	0	0	1	0	0	0	1860	88	09	9
	1	0	0	1	1	0	1	1	2110	9B	0A	Repeat
	1	0	1	0	0	1	0	1	2247	A5	0B	Spec.

To be programmed into the PROM
from ADD 08H - 13H.

4 x 7 TONE CODE FORMATS

Address 14 - 2F

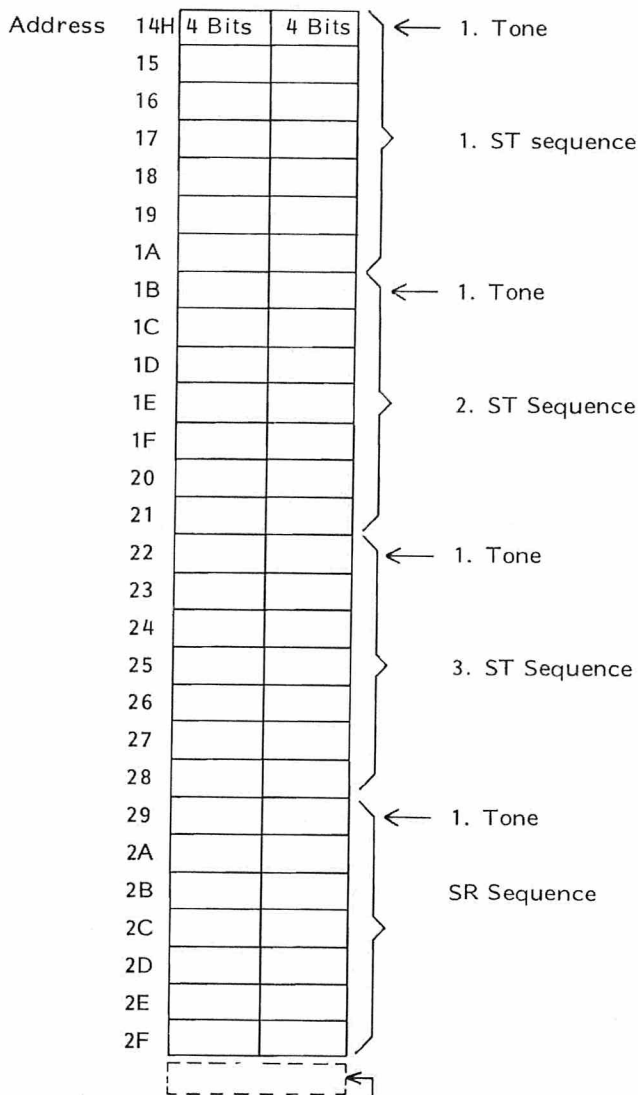

If tones are not selected from keyboard print internal Tone Index.

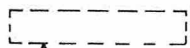
 If tones are selected from keyboard print display digits.

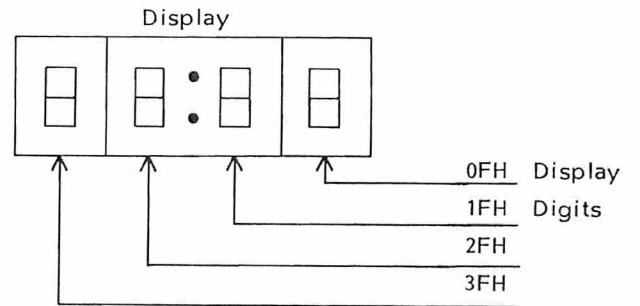

GROUP/ALL CALL ADDRESS 30

Position in the sequence where the GROUP/ALL TONE is coming (1-7)

Frequency of GROUP/ALL call tone internal tone index.

Address 30

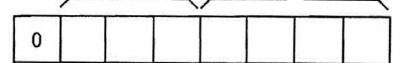

ID/ACK Address 31

"Acknowledge" when SR is activated

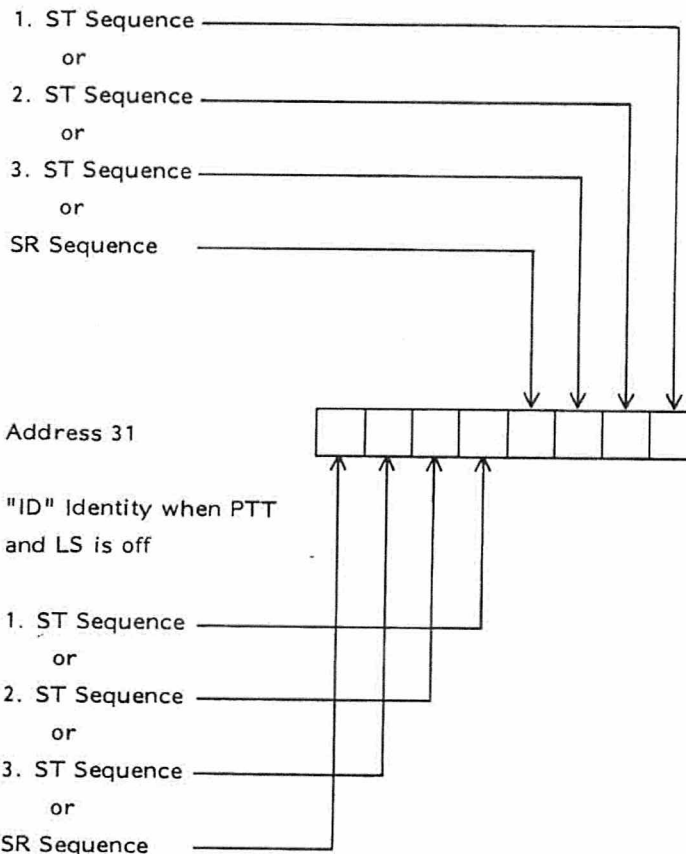

PRIVACY ADDRESS 33

DTD (TONESYSTEM/Q - VALUE) ADDRESS 32

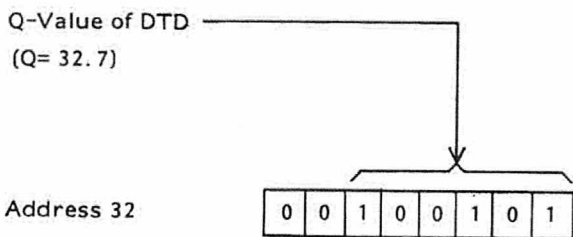

- The operator cannot open LS manually
- Keying and tone keying is not possible if the channel is busy - (true also without Privacy if LS is closed).
- LS will close automatically 0.25s - 1 min after last transmission or reception of carrier.

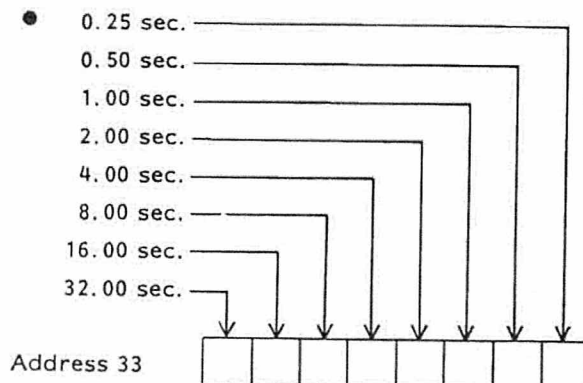

100 x RX - CODES ADDRESS 35/98

100 x TX - CODES ADDRESS 99/FC

For channel 00-99 use the formula

$$V_{DEC} = \frac{(A-10.7)-(Cx3)}{F}$$

Refer to CQM5110's handbook.

Convert then V_{DEC} - Data Hex code and insert the Hex code from address 35 channel 00 to address 98= channel 99

For channel 00-99 use the formula

$$V_{DEC} = \frac{B - (Dx3)}{F}$$

Refer to CQM5110's handbook.

Convert then V_{DEC} - Data Hex code and insert the Hex code from address 99= channel 00 to address FC= channel 99

8 Bits

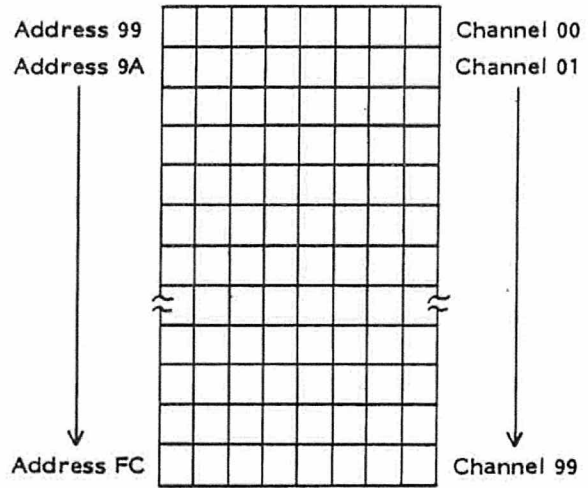
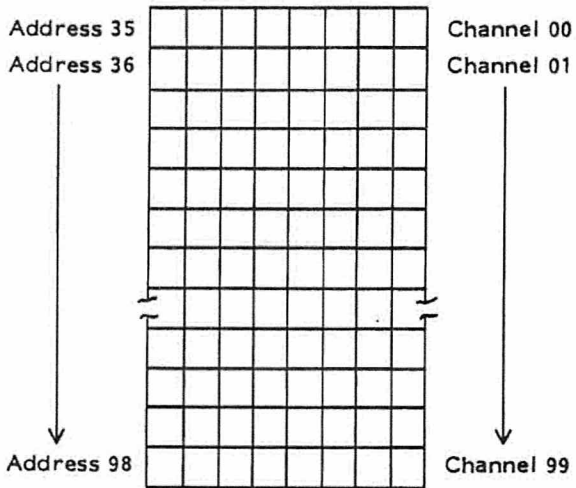

NOTE: ALL UNUSED/NOT CALCULATED CHANNELS SHALL BE PROGRAMMED FF/FREE.

Ex. for RX: (ADDRESS 35/98)

If ADDRESS 95 - 98 are unused:

THEN PROGRAMM:	ADR	BITS
95 F F	95	1 1 1 1 1 1 1 1
96 F F	96	1 1 1 1 1 1 1 1
97 F F	97	1 1 1 1 1 1 1 1
98 F F	98	1 1 1 1 1 1 1 1

PERSONALITY PROM

STORNOPHONE 5000

